HP 8702D
Lightwave Component Analyzer



© Copyright Hewlett-Packard Company 1996
All Rights Reserved. Reproduction, adaptation, or translation without prior written permission is prohibited, except as allowed under copyright laws.

HP Part No. 08702-90041
Printed in USA
April 1997

Hewlett-Packard Company
Lightwave Operations
1400 Fountaingrove Parkway
Santa Rosa, CA 95403-1799,
USA
(707) 577-1400

Notice.

The information contained in this document is subject to change without notice. Companies, names, and data used in examples herein are fictitious unless otherwise noted. Hewlett-Packard makes no warranty of any kind with regard to this material, including but not limited to, the implied warranties of merchantability and fitness for a particular purpose. Hewlett-Packard shall not be liable for errors contained herein or for incidental or consequential damages in connection with the furnishing, performance, or use of this material.

Restricted Rights Legend.

Use, duplication, or disclosure by the U.S. Government is subject to restrictions as set forth in subparagraph (c) (1) (ii) of the Rights in Technical Data and Computer Software clause at DFARS 252.227-7013 for DOD agencies, and subparagraphs (c) (1) and (c) (2) of the Commercial Computer Software Restricted Rights clause at FAR 52.227-19 for other agencies.

Warranty.

This Hewlett-Packard instrument product is warranted against defects in material and workmanship for a period of one year from date of shipment. During the warranty period, Hewlett-Packard Company will, at its option, either repair or replace products which prove to be defective. For warranty service or repair, this product must be returned to a service facility designated by Hewlett-Packard. Buyer shall prepay shipping charges to Hewlett-Packard and Hewlett-Packard shall pay shipping charges to return the product to Buyer. However, Buyer shall pay all shipping charges, duties, and taxes for products returned to Hewlett-Packard from another country.

Hewlett-Packard warrants that its software and firmware designated by Hewlett-Packard for use with an instrument will execute its programming instructions when properly installed on that instrument. Hewlett-Packard does not warrant that the operation of the instrument, or software, or firmware will be uninterrupted or error-free.

Limitation of Warranty.

The foregoing warranty shall not apply to defects resulting from improper or inadequate maintenance by Buyer, Buyer-supplied software or interfacing, unauthorized modification or misuse, operation outside of the environmental specifications for the product, or improper site preparation or maintenance.

No other warranty is expressed or implied. Hewlett-Packard specifically

disclaims the implied warranties of merchantability and fitness for a particular purpose.

Exclusive Remedies.

The remedies provided herein are buyer's sole and exclusive remedies. Hewlett-Packard shall not be liable for any direct, indirect, special, incidental, or consequential damages, whether based on contract, tort, or any other legal theory.

Safety Symbols.

CAUTION

The *caution* sign denotes a hazard. It calls attention to a procedure which, if not correctly performed or adhered to, could result in damage to or destruction of the product. Do not proceed beyond a caution sign until the indicated conditions are fully understood and met.

WARNING

The *warning* sign denotes a hazard. It calls attention to a procedure which, if not correctly performed or adhered to, could result in injury or loss of life. Do not proceed beyond a warning sign until the indicated conditions are fully understood and met.



The instruction manual symbol. The product is marked with this warning symbol when it is necessary for the user to refer to the instructions in the manual.



The laser radiation symbol. This warning symbol is marked on products which have a laser output.



The AC symbol is used to indicate the required nature of the line module input power.



The ON symbols are used to mark the positions of the instrument power line switch.



The OFF symbols are used to mark the positions of the instrument power line switch.



The CE mark is a registered trademark of the European Community.



The CSA mark is a registered trademark of the Canadian Standards Association.



This text denotes the instrument is an Industrial Scientific and Medical Group 1 Class A product.

Typographical Conventions.

The following conventions are used in this book:

Key type for keys or text located on the keyboard or instrument.

Softkey type for key names that are displayed on the instrument's screen.

Display type for words or characters displayed on the computer's screen or instrument's display.

User type for words or characters that you type or enter.

Emphasis type for words or characters that emphasize some point or that are used as place holders for text that you type.

The HP 8702D—At a Glance

The HP 8702D performs optical and electrical transmission and reflection measurements on lightwave systems and components. For most measurements, the HP 8702D imposes an electrical modulation signal on a lightwave carrier and then measures the device's response to the *modulated* lightwave signal. Typically, the HP 8702D is used with the HP 83400-series lightwave sources and receivers.

You can perform the following transmission measurements:

- Gain and loss of an optical amplifier
- Responsivity of a photo detector
- Fault location on a fiber-optic cable
- Group delay
- Insertion phase shift

The following reflection measurements are also possible:

- Return loss of modulated laser source
- Standing wave ratio (SWR)
- Impedance ($R + jX$)

Measurement accuracy—it's up to you!

Electrical and fiber-optic connectors are easily damaged when connected to dirty or damaged cables and accessories. The HP 8702D's front-panel PORT 1 and PORT 2 connector is no exception. When you use improper cleaning and handling techniques, you risk expensive instrument repairs, damaged cables, and compromised measurements. Before you connect any cables, refer to "Cleaning Connections for Accurate Measurements" on page 1-33.

The electrical connectors are also sensitive to electrostatic discharge. Before you connect any cable to the HP 8702D, refer to "Protecting Against Electrostatic Damage" on page 1-31.

Several types of devices can be characterized

With the HP 8702D, you can characterize four types of devices which are categorized according to their input and output ports. They are optical devices, lightwave sources, lightwave receivers, and electrical devices. Optical devices include fiber-optic cables, and couplers.

The HP 8702D can make electrical measurements because it has all the capabilities of an RF/microwave network analyzer. During electrical measurements, a device's response to an RF signal is measured.

Measurements are displayed in several formats

Depending on the measurement performed, the data can be viewed using one of several display formats:

- Logarithmic or linear magnitude
- Smith chart
- Polar
- Standing wave ratio
- Phase
- Real or imaginary

Time-domain measurements

In addition to transmission and reflection measurements, the HP 8702D can locate faults on fiber-optic cables and other devices. It locates faults or discontinuities in time or distance.

Displayed results can be saved and printed

You can get hardcopy results of your measurements by connecting a printer to the rear-panel PARALLEL PRINTER PORT connector. In addition, measurement results, instrument settings, and calibrations can be saved on a DOS-formatted disk using the front-panel disk drive.

CAUTION

The HP 8702D's PORT 1 and PORT 2 connectors are static sensitive. Do not touch the center conductor of these connectors. Do not allow any static charge to come into contact with it.

General Safety Considerations

This product has been designed and tested in accordance with IEC Publication 1010, Safety Requirements for Electronic Measuring Apparatus, and has been supplied in a safe condition. The instruction documentation contains information and warnings which must be followed by the user to ensure safe operation and to maintain the product in a safe condition.

WARNING

If this product is not used as specified, the protection provided by the equipment could be impaired. This product must be used in a normal condition (in which all means for protection are intact) only.

WARNING

No operator serviceable parts inside. Refer servicing to qualified personnel. To prevent electrical shock, do not remove covers.

General Safety Considerations

Contents

The HP 8702D—At a Glance iii

1 Getting Started

A Quick Tour 1-4

Changing Instrument Settings 1-12

Making Measurements Using Guided Setup 1-15

Setting the RF Output 1-21

Protecting Against Electrostatic Damage 1-31

Cleaning Connections for Accurate Measurements 1-33

2 Measuring Lightwave Sources

Making Transmission Measurements 2-4

Making Reflection Measurements 2-8

3 Measuring Lightwave Receivers

Making Transmission Measurements 3-4

Making Reflection Measurements 3-8

Measuring Phase Distortion 3-11

4 Measuring Electrical Devices

Measuring Magnitude and Insertion Phase Response 4-4

Measuring Electrical Length and Phase Distortion 4-9

Performing Time Domain Measurements 4-22

Reducing Receiver Crosstalk 4-30

Amplifier Testing 4-31

Performing Swept Power Measurements 4-35

Measuring Gain Compression 4-36

Measuring Gain and Reverse Isolation Simultaneously 4-40

Performing Harmonic Measurements

(Option 002) 4-42

Mixer Testing 4-46

Performing On-Wafer Measurements 4-62

Connection Considerations 4-63

5 Measuring Optical Devices

Making Transmission Measurements 5-4

Making Reflection Measurements 5-8

Contents

Making Time Domain Measurements 5-14

6 Optimizing Measurements

Display Functions 6-4
Increasing Measurement Accuracy 6-9
Changing the Display Format 6-12
Displaying and Saving Traces 6-21
Increasing Sweep Speed 6-25
Increasing Dynamic Range 6-30
Reducing Trace Noise 6-32
Reducing Receiver Crosstalk 6-37
Knowing the Instrument Modes 6-38

7 Measuring with Markers

General Information 7-4
Activating Markers 7-9
Setting the Measurement Range 7-12
Making Relative Measurements 7-20
Searching with Markers 7-24
Making Statistical Measurements 7-28
Using Markers with Other Display Formats 7-30
Making Other Measurements 7-34

8 Making Mixer Measurements

Measurement Considerations 8-3
Conversion Loss Using the Frequency Offset Mode 8-4
High Dynamic Range Swept RF/IF Conversion Loss 8-11
Conversion Loss Using the Tuned Receiver Mode 8-14
Phase or Group Delay Measurements 8-20
Conversion Compression Using the Frequency Offset Mode 8-23
Isolation Example Measurements 8-28
Power Meter Calibration for Mixer Measurements 8-34

9 Saving Data, States, and the Display

Saving Instrument States 9-4
Saving Measurement Data 9-7
Saving the Display to a File 9-10

Contents

Formatting Disks 9-11
If You Have Problems with Disk Storage 9-12

10 Using Limit Lines

General Information 10-4
Example 1. Creating Flat Limits 10-10
Example 2. Creating Sloping Limits 10-13
Example 3. Creating Single-Point Limits 10-15

11 Creating Sequences

General Information 11-4
Creating and Editing Sequences 11-12
Running Sequences 11-21
Saving and Printing 11-22

12 Printing and Plotting

Saving the Display to a File 12-4
Printing or Plotting the Display 12-5
Displaying Lists 12-7
Selecting Options 12-8
Connecting Printers, Plotters, and Disk Drives 12-17
If You Encounter Problems with Printing or Plotting 12-23

13 Performing Calibrations

Entering Calibration Kits and Standards 13-4
Modifying User-Defined Electrical Kits 13-7
Performing Error-Correction 13-13
Procedures for Error-Correcting Measurements 13-21
Modifying Optical Standards 13-53
Calibrating with a Power Meter 13-55

Contents

Getting Started

Getting Started

This chapter will introduce you to the HP 8702D's basic features and controls. It also shows how to make transmission and reflection measurements using *guided setups*. Guided setups are a series of menus which step you through a measurement. Guided setups provide a fast and easy method of performing lightwave measurements. After you become proficient at making simple measurements, read Chapter 2, "Measuring Lightwave Sources" through Chapter 5, "Measuring Optical Devices".

Read "Setting the RF Output" on page 1-21, to learn how to set the RF start frequency, stop frequency, and power level for your measurements. Although you can configure these settings from within guided setups, understanding how to control them manually will help you to get the most from your measurements.

Be sure to read the last two sections of this chapter. They show you how to protect your instrument from damage.

CAUTION

The HP 8702D's PORT 1 and PORT 2 connectors are static sensitive. Do not touch the center conductor of these connectors. Do not allow any static charge to come into contact with them. To protect your instrument, study the information located in "Protecting Against Electrostatic Damage" on page 1-31.

What you'll find in this chapter

- A Quick Tour 1-4
 - Front panel 1-4
 - Display 1-7
 - Rear panel 1-9
- Changing Instrument Settings 1-12
- Making Measurements Using Guided Setup 1-15
 - To make an O/E measurement 1-17
- Setting the RF Output 1-21
 - Defining the frequency range 1-21
 - Understanding the power ranges 1-22
 - Power coupling options 1-23
 - Source attenuator switch protection 1-24
 - Sweep time 1-24
 - Sweep types 1-27
 - Alternate and chop sweep modes 1-29
- Protecting Against Electrostatic Damage 1-31
- Cleaning Connections for Accurate Measurements 1-33
 - Cleaning Optical Connectors 1-34
 - Cleaning Electrical Connections 1-40

A Quick Tour

Use this section to identify the instrument's front and rear panel features and to learn how to change the instrument's settings.

Front panel

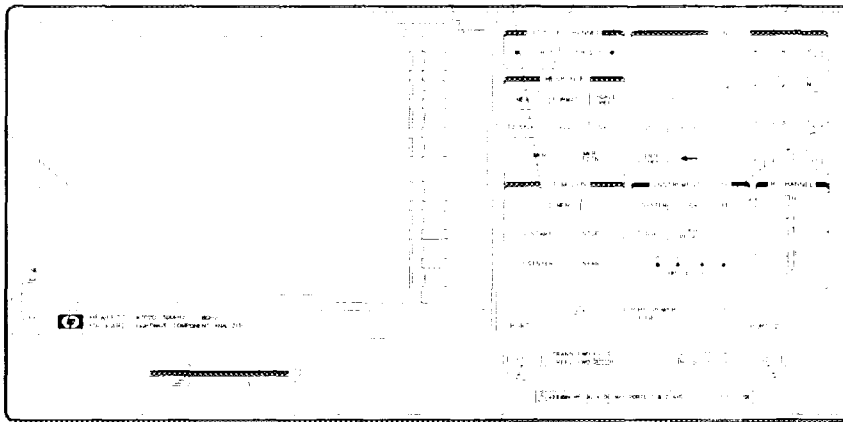

Figure 1-1. HP 8702D Front Panel

- 1** LINE switch. This switch controls ac power to the analyzer. 1 is on, 0 is off.
- 2** Display. This shows the measurement data traces, measurement annotation, and softkey labels. The display is divided into specific information areas,

illustrated in Figure 1-2.

- 3** Softkeys. These keys provide access to menus that are shown on the display.
- 4** STIMULUS function block. The keys in this block allow you to control the analyzer source's frequency, power, and other stimulus functions.
- 5** RESPONSE function block. The keys in this block allow you to control the measurement and display functions of the active display channel.
- 6** ACTIVE CHANNEL keys. The analyzer has two independent display channels. These keys allow you to select the active channel. Then any function you enter applies to this active channel.
- 7** The ENTRY block. This block includes the knob, the step (\uparrow , \downarrow) keys, and the number pad. These allow you to enter numerical data and control the markers.
- 8** INSTRUMENT STATE function block. These keys allow you to control channel-independent system functions, such as the following:
 - copying, save/recall, and HP-IB controller mode
 - limit testing
 - external source mode
 - tuned receiver mode
 - frequency offset mode
 - test sequence function
 - harmonic measurements (Option 002)
 - time domain transform

HP-IB STATUS indicators are also included in this block.

- 9** PRESET key. This key returns the instrument to either a known factory preset state, or a user preset state that can be defined.
- 10** PORT 1 and PORT 2. These ports output a signal from the source and receive input signals from a device under test. PORT 1 allows you to measure S_{12} and S_{11} . PORT 2 allows you to measure S_{21} and S_{22} .

Option 011 R, A, and B connector. These connectors allow you to apply input signals when creating your own test setup. In addition these connectors allow you to use the HP 85046A/B, HP 85047A, or HP 85044A/B test sets to simplify measurement setup.

Option 011 RF OUT connector. This connects the RF output signal from the analyzer's internal source to a test set or power splitter.
- 11** PROBE POWER connector. This connector (fused inside the instrument) supplies power to an active probe for in-circuit measurements of ac circuits.

A Quick Tour

- 12** R CHANNEL connectors. These connectors allow you to apply an input signal to the analyzer's R channel, for frequency offset mode.
- 13** Disk drive. This 3.5-inch drive allows you to store and recall instrument states and measurement results for later analysis.

Display

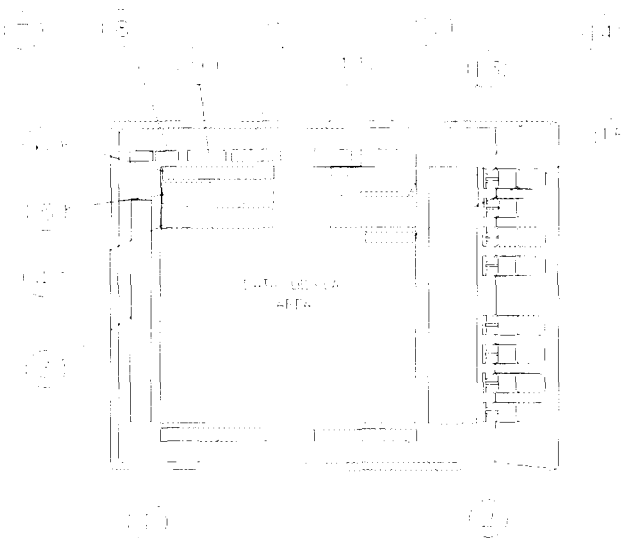

Figure 1-2. Analyzer Display (Single Channel, Cartesian Format)

The analyzer display shows various measurement information:

- the grid where the analyzer plots the measurement data.
- the currently selected measurement parameters.
- the measurement data traces.

1 Stimulus Start Value. This value could be any one of the following:

- the start frequency of the source in frequency domain measurements.
- the start time in CW mode (0 seconds) or time domain measurements.
- the lower power value in power sweep.

When the stimulus is in center/span mode, the center stimulus value is shown in this space.

2 Stimulus Stop Value. This value could be any one of the following:

- the stop frequency of the source in frequency domain measurements.
- the stop time in time domain measurements or CW sweeps.
- the upper limit of a power sweep.

A Quick Tour

When the stimulus is in center/span mode, the span is shown in this space. The stimulus values can be blanked.

- 3** Status Notations. This area shows the current status of various functions for the active channel.
- 4** Active Entry Area. This displays the active function and its current value.
- 5** Message Area. This displays prompts or error messages.
- 6** Title. This is a descriptive alpha-numeric string title that you define and enter through an attached keyboard.
- 7** Active Channel. This is the number of the current active channel, selected with the ACTIVE CHANNEL keys. If dual channel is on with an overlaid display, both channel 1 and channel 2 appear in this area.
- 8** Measured Input(s). This shows the S-parameter, input, or ratio of inputs currently measured, as selected using the MEAS key. Also indicated in this area is the current display memory status.
- 9** Format. This is the display format that you selected using the FORMAT key.
- 10** Scale/Div. This is the scale that you selected using the SCALE REF key, in units appropriate to the current measurement.
- 11** Reference Level. This value is the reference line in Cartesian formats or the outer circle in polar formats, whichever you selected using the SCALE REF key. The reference level is also indicated by a small triangle adjacent to the graticule, at the left for channel 1 and at the right for channel 2.
- 12** Marker Values. These are the values of the active marker, in units appropriate to the current measurement.
- 13** Marker Stats, Bandwidth. These are statistical marker values that the analyzer calculates when you access the menus with the MARKER FCTN key.
- 14** Softkey Labels. These menu labels redefine the function of the softkeys that are located to the right of the analyzer display.
- 15** Pass/Fail. During limit testing, the result will be announced as "PASS" if the limits are not exceeded, and "FAIL" if any points exceed the limits.

Rear panel

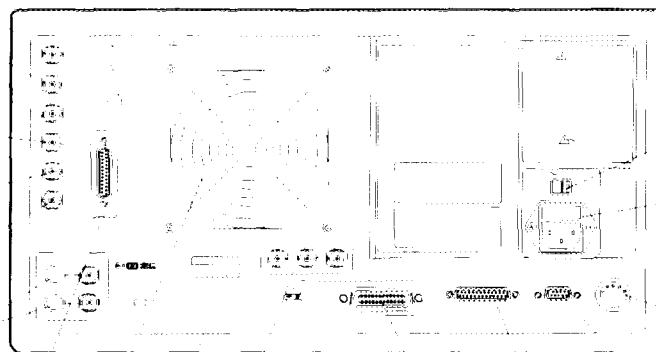
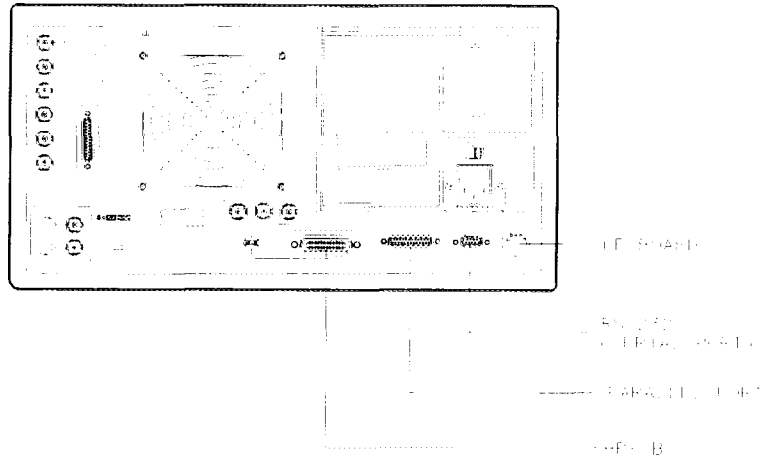

Figure 1-3. HP 8702D Rear Panel

- 1** Serial number plate.
- 2** External Monitor. Red, green, and blue video output connectors provide analog red, green, and blue video signals which you can use to drive an external monitor, such as the HP 3571A/B, or monochrome monitor, such as the HP 35731A/B. You can use other analog multi-sync monitors if they are compatible with the analyzer's 25.5 kHz scan rate and video levels: 1 V p-p, 0.7 V=white, 0 V=black, -0.3 V sync, sync on green.
- 3** HP-IB connector. This allows you to connect the analyzer to an external controller, compatible peripherals, and other instruments for an automated system.
- 4** PARALLEL connector. This connector allows the analyzer to output to a peripheral with a parallel input. Also included, is a general purpose input/output (GPIO) bus that can control eight output bits and read five input bits through test sequencing.
- 5** RS-232 connector. This connector allows the analyzer to output to a peripheral with an RS-232 (serial) input.

A Quick Tour

- 6** KEYBOARD input (DIN) connector. This connector allows you to connect an external keyboard. This provides a more convenient means to enter a title for storage files, as well as substitute for the analyzer's front panel keyboard. The keyboard must be connected to the analyzer before the power is switched on.
- 7** Power cord receptacle, with fuse.
- 8** Line voltage selector switch.
- 9** 10 MHZ REFERENCE ADJUST. (Option 1D5)
- 10** 10 MHZ PRECISION REFERENCE OUTPUT. (Option 1D5)
- 11** EXTERNAL REFERENCE INPUT connector. This allows for a frequency reference signal input that can phase lock the analyzer to an external frequency standard for increased frequency accuracy.
- 12** AUXILIARY INPUT connector. This allows for a dc or ac voltage input from an external signal source, such as a detector or function generator, which you can then measure, using the S-parameter menu.
- 13** EXTERNAL AM connector. This allows for an external analog signal input that is applied to the ALC circuitry of the analyzer's source. This input analog signal amplitude modulates the RF output signal.
- 14** EXTERNAL TRIGGER connector. This allows connection of an external negative-going TTL-compatible signal that will trigger a measurement sweep. The trigger can be set to external through softkey functions.
- 15** TEST SEQUENCE. Outputs a TTL signal that can be programmed in a test sequence to be high or low, or pulse (10 μ seconds) high or low at the end of a sweep for robotic part handler interface.
- 16** LIMIT TEST. Outputs a TTL signal of the limit test results as follows:
 - Pass: TTL high
 - Fail: TTL low
- 17** BIAS INPUTS AND FUSES. These connector bias devices connected to port 1 and port 2. The fuses (1 A, 125 V) protect the port 1 and port 2 bias lines.
- 18** TEST SET INTERCONNECT. This allows you to connect an HP 8702D Option 011 analyzer to an HP 85046A/B or 85047A S-parameter test set using the interconnect cable supplied with the test set. The S-parameter test set is then fully controlled by the analyzer.



qq612d

Figure 1-4. Rear Panel Connectors

Changing Instrument Settings

Once a function is selected, by a front-panel key or softkey, it is “active” and its value is shown in the display’s active function area. Use the numeric keypad, the knob, and the step keys to change the value of active functions. Generally, the keypad, knob, and step keys can be used interchangeably. If no other functions are activated, the knob moves the active marker.

You can use the ENTRY OFF key to clear and turn off the active entry area, as well as any displayed prompts, error messages, or warnings. Use this function to clear the display before plotting. This key is also helpful in preventing the changing of active values by accidentally moving the knob.

Use the ← key to delete the last entry, or the last digit entered from the numeric keypad.

Terminating number entries

The units terminator keys are the four keys in the right column of the keypad. You must use these keys to specify units of numerical entries from the keypad. A numerical entry is incomplete until a terminator is supplied. The analyzer indicates that an input is incomplete by a data entry arrow ← pointing at the last entered digit in the active entry area. When you press the units terminator key, the arrow is replaced by the units you selected.

Table 1-1. Unit Keys

Key	Description
G/n	Giga/nano ($10^9 / 10^{-9}$)
M/ μ	Mega/micro ($10^6 / 10^{-6}$)
k/m	kilo/milli ($10^3 / 10^{-3}$)
x1	basic units: dB, dBm, degrees, seconds, Hz, or dB/GHz (may be used to terminate unitless entries, such as averaging factor)

Stepping entry values up or down

You can use the step keys ↑ (up) and ↓ (down) to step the current value of the active function up or down. The analyzer defines the steps for different functions. No units terminator is required.

The PRESET key sets the instrument to its default state

As you perform your measurements, remember that you can always return the HP 8702D to its factory default settings by pressing the front-panel PRESET key. Pressing PRESET also returns any guided setup settings to their default values. If you leave guided setup by pressing some other key, you can return to your last guided setup menu by pressing the front-panel SYSTEM key.

Two measurements can be displayed simultaneously

The analyzer has two digital channels for independent measurements. You can view both the active and inactive channel traces, either overlaid or on separate graticules one above the other (split display). The dual channel and split display features are accessed through the display menus.

The two channels allow you to measure and view two different sets of data simultaneously. For example, the analyzer can display the reflection and transmission characteristics of a device, or one measurement with two different frequency spans.

Use the CHAN 1 and CHAN 2 keys to select the “active channel.” All of the channel-specific keys that you select apply to the active channel. The current active channel is indicated by an amber LED adjacent to the corresponding channel key.

The two channels are normally coupled

Normally, the two channels are coupled. With the *COUPLED CH ON off* key set to on (the preset condition), both channels have the same stimulus values (the inactive channel takes on the stimulus values of the active channel).

In the stimulus coupled mode, the following parameters are coupled:

- frequency
- number of points
- source power
- number of groups
- power slope
- IF bandwidth
- sweep time
- trigger type
- gating parameters

Changing Instrument Settings

- sweep type
- harmonic measurement
- power meter calibration

You can uncouple the stimulus values between the two display channels by pressing *COUPLED CH ON off*. This allows you to assign different stimulus values for each channel; it's almost like having the use of a second analyzer. The coupling and uncoupling of the stimulus values for the two channels is independent of the display and marker functions.

Coupling of stimulus values for the two channels is independent of *DUAL CHAN on OFF* in the display menu and *MARKERS: UNCOUPLED* in the marker mode menu. Measurement markers can have the same stimulus values (coupled) for the two channels, or they can be uncoupled for independent control in each channel. *COUPLED CH on OFF* becomes an alternate sweep function when dual channel display is on; in this mode the analyzer alternates between the two sets of stimulus values for measurement of data and both are displayed.

Making Measurements Using Guided Setup

In this section, you'll learn how to make fast, easy measurements using the HP 8702D's guided setup feature. When you first turn on the instrument or press the green PRESET key, the *GUIDED SETUP* softkey is displayed. Simply press *GUIDED SETUP*, and follow the displayed instructions.

Guided setups contain the instructions you need to perform accurate measurements including:

- Diagrams of equipment connections.
- RF source's start frequency, stop frequency, and power level.
- Calibration.

The first step in the procedure is to select either *BANDWIDTH* (transmission) or *REFLECTION* measurements. With bandwidth measurements, you select one of the following four types of devices to measure:

- E/E (electrical device)
- E/O (lightwave source)
- O/E (lightwave receiver)
- O/O (optical device)

With reflection measurements, you select the type of port that you are characterizing on your device:

- 1-PORT ELECTRICAL
- 1-PORT OPTICAL

In guided setups, always press *CONTINUE* to display the next set of instructions.

This section provides step-by-step instructions for characterizing an O/E device. Because all of the guided setup procedures are similar, after performing this procedure, you should be able to perform any of the other procedures.

You'll need HP 83400-series lightwave sources and receivers

For any measurements other than E/E or 1-PORT ELECTRICAL, you'll need HP 83400-series lightwave sources and receivers to provide modulation and demodulation of the light signal. These sources and receivers come with

Making Measurements Using Guided Setup

calibration data that is stored on a 3.5 inch diskette. During a guided setup procedure, you'll be prompted to insert the disk into the HP 8702D's front-panel disk drive in order to read the calibration data.

Calibration improves measurement accuracy

An important part of making measurements, including those in guided setups, is performing a calibration. Calibration removes certain repeatable errors from your measurements that are associated with the test setup. During guided setup procedures, you'll perform a *RESPONSE* calibration. This calibration corrects for the test setup's frequency response. During E/O and O/E procedures you can choose to perform a *RESPONSE & MATCH* calibration instead. This calibration is more accurate but requires several additional steps. A *RESPONSE & MATCH* calibration characterizes the test setup at the measurement plane. This involves temporarily disconnecting the source or receiver and measuring open, short, and load calibration standards.

You'll need an HP calibration kit

HP calibration kits include the open, short, and load required to make *RESPONSE & MATCH* calibrations during measurements.

HP 83400 substitution during calibration

Whenever you're characterizing an E/O or O/E device, the calibration is performed after temporarily substituting an HP 83400 source or receiver for the device you're testing. After the calibration has completed, your device is re-inserted into the test setup, and the measurement is performed. For example, suppose that you want to measure the bandpass of an E/O device. You first connect the test setup using your device and an HP 83400-series lightwave receiver. During the first part of the guided setup procedure, you'll set the measurement parameters. Then during calibration, you'll remove your device and substitute an HP 83400-series lightwave source. After the calibration is complete, the procedure prompts you to remove the HP 83400-series lightwave source and re-insert your test device.

To make an O/E measurement

This step-by-step procedure takes you through the measurement of a typical O/E device. During the procedure, you'll perform a *RESPONSE & MATCH* calibration. If your device requires different measurement parameters (for example, the start frequency), simply change them as needed.

In order to perform this procedure, you'll need an HP 83400-series lightwave receiver with its calibration data disk, a lightwave source, an HP calibration kit, and a receiver that you want to characterize.

- 1 Connect the test equipment as shown in the following figure.

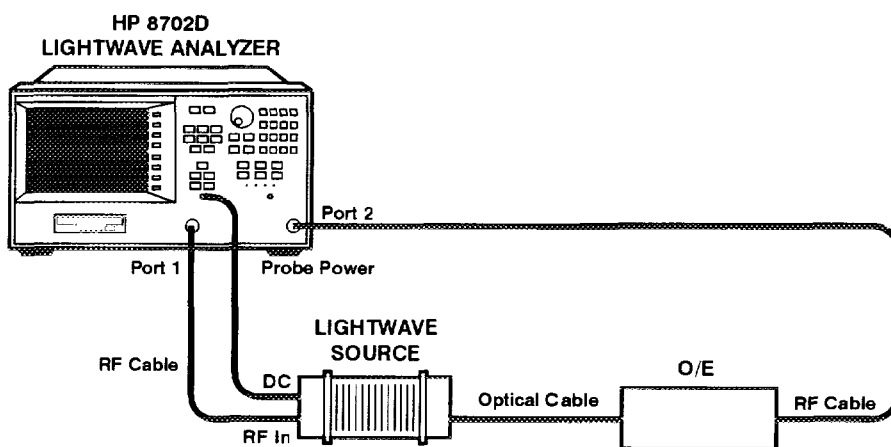

Circ

Figure 1-5. Initial test setup

- 2 Press *PRESET* to set the instrument to its default condition.
- 3 Press *GUIDED SETUP*, *BANDWIDTH*, and then *CONTINUE*.
- 4 Press *O/E*, *CONTINUE*, and then *CONTINUE*.
- 5 Use the *START* and *STOP* softkeys to enter the frequency limits for the modulation. Then, press *CONTINUE*.

Making Measurements Using Guided Setup

The *NUMBER OF POINTS* softkey allows you to change the number of measurement points taken during each sweep. The default setting is normally adequate for most measurements.

- 6 Use the *RF SOURCE POWER* softkey to set the power level, and then press *CONTINUE*.

Use the *SWEEP TIME* softkey to decrease the sweep time if needed. Although this results in faster measurements, sweeps that are too fast will distort the displayed response. If this happens, increase the sweep time until changes no longer effect the displayed trace.

- 7 Press *RESPONSE & MATCH* to select the most extensive calibration procedure.

Because you're performing the additional electrical match calibration, you'll need a calibration kit which includes open, short, and load calibration standards.

- 8 Press *CAL KIT*, and select the calibration kit that you will be using. Then press *PRIOR MENU*.

- 9 Press *DEFINE RECEIVER*. Insert the calibration disk that came with the HP 83400-series lightwave receiver into the HP 8702D's front-panel disk drive.

- 10 Press *LOAD DISK CAL DATA*, and when the data is finished loading, press *LOAD RCVR1 DISK*. Then press *CONTINUE*.

- 11 Disconnect the RF cable from the input to the lightwave source. If an adapter is needed to make the RF thru connection described in Step 13, it should be connected between the RF cable and the open, short, and load. Connect the "open" connector from the calibration kit. Step through the menus measuring the open, short, and broadband (load). For the remainder of the test, do not disconnect the cable from the HP 8702D. Refer to Figure 1-6 on page 1-19.

- 12 Disconnect the RF cable from the output of the lightwave receiver. Connect the "open" connector from the calibration kit. Step through the menus measuring the open, short, and broadband (load). For the remainder of the test, do not disconnect the cable from the HP 8702D.

- 13 Use an RF "through" connector to connect the two RF cables together. Press *RF THRU* and then *DONE: RF THRU*.

- 14 Connect the lightwave source and lightwave receiver as shown on the HP 8702D's display. Refer to Figure 1-7 on page 1-19.

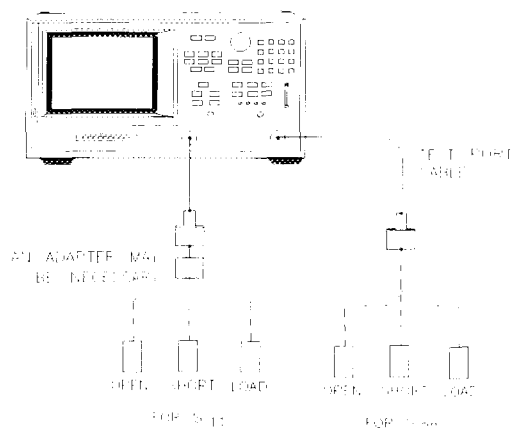

Figure 1-6. Match calibration

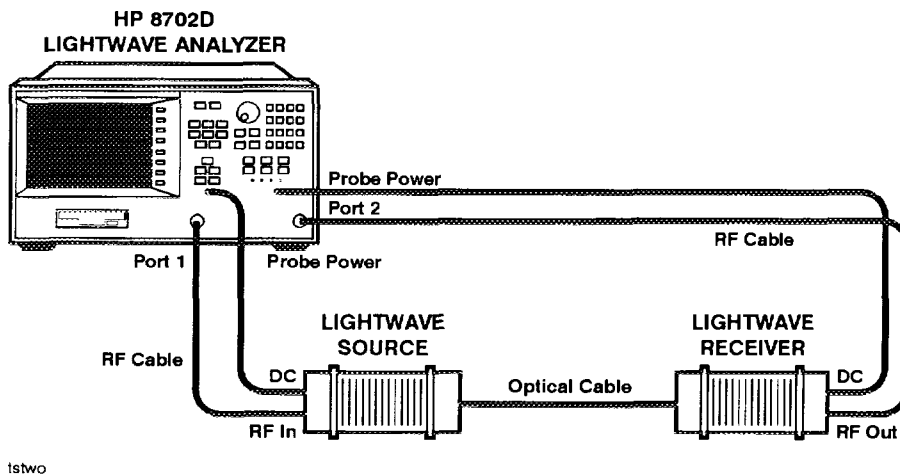
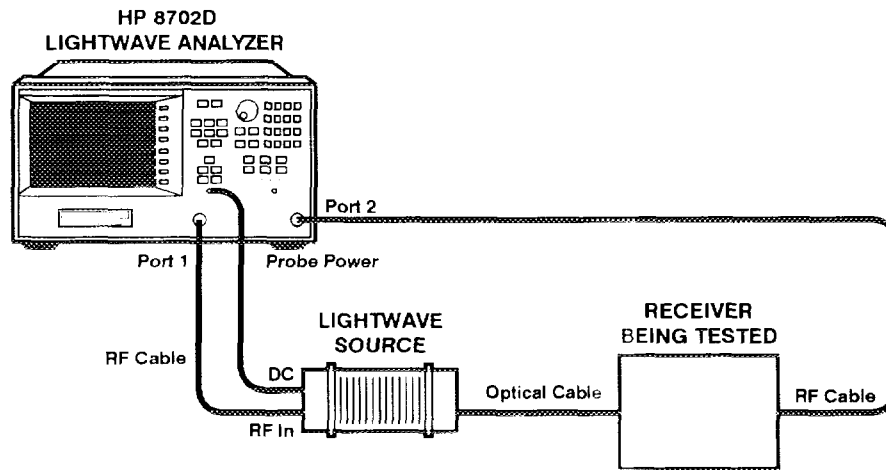

Figure 1-7. Calibration with lightwave receiver

- 15 Press *RECEIVER* and then *DONE RECEIVER*.
- 16 Press *DISK (1)* and then *DONE: SRC + RCVR*.

Making Measurements Using Guided Setup

- 17** Is the noise floor higher than the crosstalk?
- Yes—press *OMIT ISOLATION*, and then press *DONE: ISOL'N STD.*
 - No—disconnect the fiber-optic cable from the lightwave source's output connector, and press *ISOLN LOAD*. Reconnect the fiber-optic cable, and then press *DONE: ISOL'N STD.*
 - If you are not sure, then omit isolation.
- 18** Remove the HP 83400-series lightwave receiver, and replace it with the receiver that you want to test.



tsone

Figure 1-8. Final setup for measurements

- 19** Press *VIEW MEASURE*. The bandpass measurement of your receiver is shown on the display.

Setting the RF Output

The stimulus function block keys are used to define the source RF output signal to the test device by providing control of the following parameters:

- swept frequency ranges
- time domain start and stop times
- RF power level and power ranges
- channel and test port coupling
- sweep time
- sweep type
- number of data points
- sweep trigger

The MENU key provides access to the series of menus which are used to define and control all stimulus functions other than start, stop, center, and span. When the MENU key is pressed, the stimulus menu is displayed.

The stimulus menu is used to specify the sweep time, number of measurement points per sweep, and CW frequency. It includes the capability to couple or uncouple the stimulus functions of the two display channels, and the measurement restart function. In addition, it leads to other softkey menus that define power level, trigger type, and sweep type.

Defining the frequency range

The START, STOP, CENTER, and SPAN keys are used to define the frequency range or other horizontal axis range of the stimulus. The range can be expressed as either start/stop or center/span. When one of these keys is pressed, its function becomes the active function. The value is displayed in the active entry area and can be changed with the knob, step keys, or numeric keypad. Current stimulus values for the active channel are also displayed along the bottom of the graticule. Frequency values can be blanked for security purposes, using the display menus.

Setting the RF Output

The preset stimulus mode is frequency, and the start and stop stimulus values are set to 30 kHz and 3 GHz (or 6 GHz with Option 006) respectively. In the time domain or in CW time mode, the stimulus keys refer to time (with certain exceptions). In power sweep, the stimulus value is in dBm.

Because the display channels are independent, the stimulus signals for the two channels can be uncoupled and their values set independently. The values are then displayed separately if the instrument is in dual channel display mode. In the uncoupled mode with dual channel display the instrument takes alternate sweeps to measure the two sets of data. Before performing O/E or E/O calibration verify that the HP 83400 source or receiver is specified for operation over the desired frequency span.

Understanding the power ranges

The built-in synthesized source contains a programmable step attenuator that allows you to directly and accurately set power levels in eight different power ranges. Each range has a total span of 25 dB. The eight ranges cover the instrument's full operating range from +10 dBm to -85 dBm. A power range can be selected either manually or automatically.

Automatic mode

If you select *PWR RANGE AUTO*, you can enter any power level within the total operating range of the instrument and the source attenuator will automatically switch to the corresponding range.

Each range overlaps its adjacent ranges by 15 dB, therefore, certain power levels are designated to cause the attenuator to switch to the next range so that optimum (leveled) performance is maintained. These transition points exist at -10 dB from the top of a range and at +5 dB from the bottom of a range. This leaves 10 dB of operating range. By turning the front-panel knob with *PORT POWER* being the active function, you can hear the attenuator switch as these transitions occur.

Manual mode

If you select *PWR RANGE MAN*, you must first manually select the power range that corresponds to the power level you want to use. This is accomplished by pressing the *POWER RANGES* softkey and then selecting one of the eight available ranges. In this mode, you will not be able to use the step keys, knob, or keypad entry to select power levels outside the range limits. This feature is necessary to maintain accuracy once a measurement calibration is turned on.

When a calibration is completed and turned on, the power range selection is switched from auto to manual mode, and the annotation PRM appears on the display.

Note

A measurement calibration is valid *only* for the power level at which it was performed; but you can change the power within a range and still maintain nearly full accuracy. If you decide to switch power ranges, the calibration is no longer valid and specified accuracy is forfeited. However, the analyzer leaves the correction *on* even though it's invalid. The annotation C? will be displayed whenever you change the power after calibration.

Power coupling options

There are two methods you can use to couple and uncouple power levels with the HP 8702D: channel coupling and port coupling. By uncoupling the channel powers, you effectively have two separate sources. Uncoupling the test ports allows you to have different power levels on each port.

Channel coupling

CHAN POWER [COUPLED] toggles between coupled and uncoupled channel power. With the channel power coupled, the power level is the same on each channel. With the channel power uncoupled, you can set different power levels for each channel. For the channel power to be uncoupled, the other channel stimulus functions must also be uncoupled (*COUPLED CH on OFF*).

Test port coupling

PORT POWER [COUPLED] toggles between coupled and uncoupled test ports. With the test ports coupled, the power level is the same at each port. With the ports uncoupled, you can set a different power level at each port. This can be useful, for example, if you want to simultaneously perform a gain and reverse isolation measurement on a high-gain amplifier using the dual channel mode to display the results. In this case, you would want the power in the forward direction (S_{21}) much lower than the power in the reverse direction (S_{12}).

Source attenuator switch protection

The programmable step attenuator of the source can be switched between port 1 and port 2 when the test port power is uncoupled or between channel 1 and channel 2 when the channel power is uncoupled. To avoid premature wear of the attenuator, measurement configurations requiring continuous switching between different power ranges are not allowed.

For example, channels 1 and 2 of the analyzer are decoupled, power levels in two different ranges are selected for each channel, and dual channel display is engaged. To prevent continuous switching between the two power ranges, the analyzer automatically engages the test set hold mode after measuring both channels once. The active channel continues to be updated each sweep while the inactive channel is placed in the hold mode. (The status annotation *tsh* appears on the left side of the display.) If averaging is on, the test set hold mode does not engage until the specified number of sweeps is completed. The *MEASURE RESTART* and *NUMBER OF GROUPS* softkeys can override this protection feature.

The *MEASURE RESTART* and *NUMBER OF GROUPS* softkeys allow measurements which demand repetitive switching of the step attenuator. Use these softkeys with caution; repetitive switching can cause premature wearing of the attenuator.

- *MEASURE RESTART* causes one measurement to occur.
- *NUMBER OF GROUPS* causes a specified number of measurements to occur before activating the test set hold mode.

Sweep time

The *SWEEP TIME* softkey selects sweep time as the active entry and shows whether the automatic or manual mode is active. The following explains the difference between automatic and manual sweep time:

- Manual sweep time. As long as the selected sweep speed is within the capability of the instrument, it will remain fixed, regardless of changes to other measurement parameters. If you change measurement parameters such that the instrument can no longer maintain the selected sweep time, the analyzer will change to the fastest sweep time possible.
- Auto sweep time. Auto sweep time continuously maintains the fastest sweep

speed possible with the selected measurement parameters. For some test configurations, such as those that include a source, optical fiber, and a receiver, the auto sweep time may be too short. Manually set a sweep time long enough for the signals to propagate through the test setup.

Sweep time refers only to the time that the instrument is sweeping and taking data, and does not include the time required for internal processing of the data. A sweep speed indicator \uparrow is displayed on the trace for sweep times slower than 1.0 second. For sweep times faster than 1.0 second the \uparrow indicator appears in the status notations area at the left of the analyzer's display.

The minimum sweep time is dependent on several of the following factors.

- the number of points selected
- IF bandwidth
- sweep-to-sweep averaging in dual channel display mode
- smoothing
- limit test
- error correction
- trace math
- marker statistics
- time domain
- type of sweep

Use the following table to determine the minimum sweep time for the listed measurement parameters. The values listed represent the minimum time required for a CW time measurement with averaging off. Values are given in seconds.

Table 1-2. Minimum Sweep Time (in seconds)

Number of Points	IF Bandwidth			
	3000 Hz	1000 Hz	300 Hz	10 Hz
11	0.0055s	0.012s	0.037s	1.14s
51	0.0255s	0.060s	0.172s	5.30s
101	0.0505s	0.120s	0.341s	10.5s
201	0.1005s	0.239s	0.679s	20.9s
401	0.2005s	0.476s	1.365s	41.7s
801	0.4005s	0.951s	2.701s	83.3s
1601	0.8005s	1.901s	5.411s	166.5s

Sweep time may be used in manual or auto modes. These are explained below.

Manual sweep time mode

When this mode is active, the softkey label reads *SWEEP TIME [MANUAL]*. This mode is engaged whenever you enter a sweep time greater than zero. This mode allows you to select a fixed sweep time. If you change the measurement parameters such that the current sweep time is no longer possible, the analyzer will automatically increase to the next fastest sweep time possible. If the measurement parameters are changed such that a faster sweep time is possible, the analyzer will not alter the sweep time while in this mode.

Auto sweep time mode

When this mode is active, the softkey label reads *SWEEP TIME [AUTO]*. This mode is engaged whenever you enter 0, x1 as a sweep time. Auto sweep time continuously maintains the fastest sweep time possible with the selected measurement parameters.

Sweep types

Five sweep types are available.

- linear frequency sweep
- logarithmic frequency sweep
- list frequency sweep
- power sweep
- CW time sweep

Linear frequency sweep (Hz)

The *LIN FREQ* softkey activates a linear frequency sweep displayed on a standard graticule with ten equal horizontal divisions. This is the preset default sweep type. For a linear sweep, sweep time is combined with the channel's frequency span to compute a source sweep rate:

$$\text{sweep rate} = \frac{\text{frequency span}}{\text{sweep time}}$$

Since the sweep time may be affected by various factors, the equation provided here is merely an indication of the ideal (fastest) sweep rate. If the user-specified sweep time is greater than 15 ms times the number of points, the sweep changes from a continuous ramp sweep to a stepped CW sweep. Also, for 10 Hz or 30 Hz IF bandwidths, the sweep is automatically converted to a stepped CW sweep.

In the linear frequency sweep mode it is possible to transform the data for time domain measurements using the inverse Fourier transform technique.

Logarithmic frequency sweep (Hz)

The *LOG FREQ* softkey activates a logarithmic frequency sweep mode. The source is stepped in logarithmic increments and the data is displayed on a logarithmic graticule. This is slower than a continuous sweep with the same number of points, and the entered sweep time may therefore be changed automatically. For frequency spans of less than two octaves, the sweep type automatically reverts to linear sweep.

List frequency sweep (Hz)

The *LIST FREQ* softkey provides a user-definable arbitrary frequency list mode. This list is defined and modified using the edit list menu and the edit sub-sweep menu. Up to 30 frequency subsweeps (called "segments") of several

different types can be specified, for a maximum total of 1632 points. One list is common to both channels. Once a frequency list has been defined and a measurement calibration performed on the full frequency list, one or all of the frequency segments can be measured and displayed without loss of calibration.

When the *LIST FREQ* key is pressed, the analyzer sorts all the defined frequency segments into *CW* points in order of increasing frequency. It then measures each point and displays a single trace that is a composite of all data taken. If duplicate frequencies exist, the analyzer makes multiple measurements on identical points to maintain the specified number of points for each subsweep. Since the frequency points may not be distributed evenly across the display, the display resolution may be uneven, and more compressed in some parts of the trace than in others. However, the stimulus and response readings of the markers are always accurate. Because the list frequency sweep is a stepped *CW* sweep, the sweep time is slower than for a continuous sweep with the same number of points.

The *LIST FREQ* softkey presents the segment menu, which allows you to select any single segment in the frequency list. If no list has been entered, the message **CAUTION: LIST TABLE EMPTY** is displayed.

A tabular printout of the frequency list data can be obtained using the *LIST VALUES* function in the copy menu.

Power sweep (dBm)

The *POWER SWEEP* softkey turns on a power sweep mode that is used to characterize power-sensitive circuits. In this mode, power is swept at a single frequency, from a start power value to a stop power value, selected using the *START* and *STOP* keys and the entry block. This feature is convenient for such measurements as gain compression or AGC (automatic gain control) slope. To set the frequency of the power sweep, use *CW FREQ* in the stimulus menu.

The span of the swept power is limited to being equal to or within one of the eight pre-defined power ranges. The attenuator will not switch to a different power range while in the power sweep mode. Therefore, when performing a power sweep, power range selection will automatically switch to the *manual* mode.

In power sweep, the entered sweep time may be automatically changed if it is less than the minimum required for the current configuration (number of points, IF bandwidth, averaging, etc.).

CW time sweep (seconds)

The *CW TIME* softkey turns on a sweep mode similar to an oscilloscope. The analyzer is set to a single frequency, and the data is displayed versus time. The frequency of the CW time sweep is set with *CW FREQ* in the stimulus menu. In this sweep mode, the data is continuously sampled at precise, uniform time intervals determined by the sweep time and the number of points minus 1. The entered sweep time may be automatically changed if it is less than the minimum required for the current instrument configuration.

In time domain, the CW time mode data is translated to frequency domain, and the x-axis becomes frequency. This can be used as a spectrum analyzer to measure signal purity, or for low frequency (400 MHz wide), maximum dynamic range may not be achieved.

Interpolated error correction

The interpolated error correction feature will function with the following sweep types:

- linear frequency
- power sweep
- CW time

Interpolated error correction will not work in log or list sweep modes.

Alternate and chop sweep modes

CHOP A and B measures both inputs A and B during each sweep. Thus, if each channel is measuring a different parameter and both channels are displayed, the chop mode offers the fastest measurement time. This is the preferred measurement mode for full two-port calibrations because both inputs remain active. This is the default measurement mode.

The disadvantage of this mode is that in measurements of high rejection devices, such as filters with a low-loss passband (>400 MHz wide), maximum dynamic range may not be achieved.

ALTERNATE A and B measures only one input per frequency sweep, in order to reduce spurious signals. Thus, this mode optimizes the dynamic range for all four S-parameter measurements.

The disadvantages of this mode are associated with simultaneous transmission/reflection measurements or full two-port calibrations: this mode takes twice as long as the chop mode to make these measurements. In addition, the

Setting the RF Output

port match changes on the order of < -45 dB due to either input A or B being inactive during each sweep. This may affect transmission measurements on the order of < 0.01 dB.

To access the *ALTERNATE A and B* and *CHOP A and B* soft keys press *CAL MORE*. The following figure shows the *alternate* sweep mode (bold trace) overlaying the *chop* sweep mode in a band-pass filter measurement. Note the difference in the noise levels between the two modes.

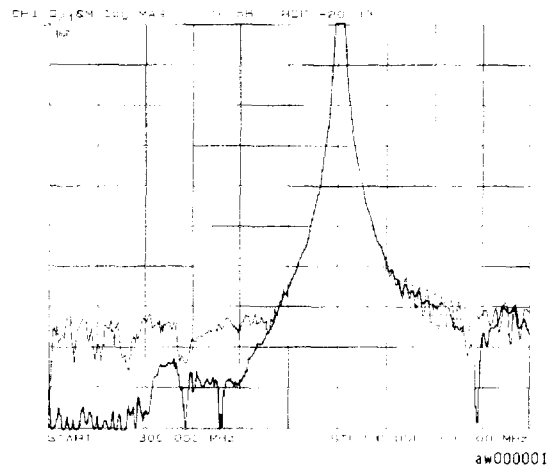
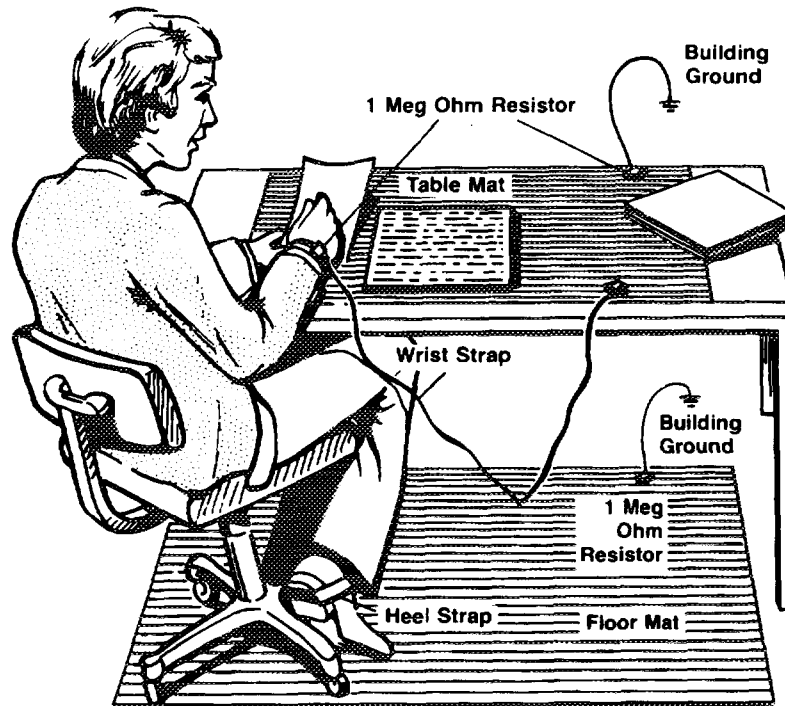

Figure 1-9. Alternate and Chop Sweeps Overlaid

Protecting Against Electrostatic Damage

Electrostatic discharge (ESD) can damage or destroy the input circuits of the HP 8702D. ESD can also damage or destroy electronic components that you are measuring. All work should be performed at a static-safe work station. The following figure shows an example of a static-safe work station (without the instrument) using two types of ESD protection:

- Conductive table-mat and wrist-strap combination.
- Conductive floor-mat and heel-strap combination.



Protecting Against Electrostatic Damage

Both types, when used together, provide a significant level of ESD protection. Of the two, only the table-mat and wrist-strap combination provides adequate ESD protection when used alone.

To ensure user safety, the static-safe accessories must provide at least 1 M Ω of isolation from ground. Refer to Table 1-3 for information on ordering static-safe accessories.

WARNING

These techniques for a static-safe work station should not be used when working on circuitry with a voltage potential greater than 500 volts.

Reducing ESD Damage

The following suggestions may help reduce ESD damage that occurs during testing and servicing operations.

- Personnel should be grounded with a resistor-isolated wrist strap before removing any assembly from the unit.
- Be sure all instruments are properly earth-grounded to prevent a buildup of static charge.

Table 1-3. Static-Safe Accessories

HP Part Number	Description
9300-0797	3M static control mat 0.6 m \times 1.2 m (2 ft \times 4 ft) and 4.6 cm (15 ft) ground wire. (The wrist-strap and wrist-strap cord are not included. They must be ordered separately.)
9300-0980	Wrist-strap cord 1.5 m (5 ft)
9300-1383	Wrist-strap, color black, stainless steel, without cord, has four adjustable links and a 7 mm post-type connection.
9300-1169	ESD heel-strap (reusable 6 to 12 months).

Cleaning Connections for Accurate Measurements

Advances in measurement capabilities make connectors and connection techniques more important than ever. Damage to the connectors on calibration and verification devices, test ports, cables, and other devices can increase downtime and expense.

Refer to “Cleaning Optical Connectors” on page 1-34 and to “Cleaning Electrical Connections” on page 1-40 for suggestions which will help you get the best performance from your connectors.

Cleaning Optical Connectors

Accurate and repeatable measurements require clean connections. Use the following guidelines to achieve the best possible performance when making measurements on a fiber-optic system:

- Keep connectors covered when not in use.
- Use dry connections whenever possible.
- Use the cleaning methods described in this section.
- Use care in handling all fiber-optic connectors.
- When inserting a fiber-optic connector into a front-panel adapter, make sure that the fiber end does not touch the outside of the mating connector or adapter.

Because of the small size of cores used in optical fibers, care must be used to ensure good connections. Poor connections result from core misalignment, air gaps, damaged fiber ends, contamination, and improper use and removal of index-matching compounds.

Use dry connections. Dry connectors are easier to clean and to keep clean. Dry connections can be used with physically contacting connectors (for example, Diamond HMS-10/HP, FC/PC, DIN, and ST). If a dry connection has 40 dB return loss or better, making a wet connection will probably not improve, and can actually degrade, performance.

CAUTION

Hewlett-Packard strongly recommends that index matching compounds *not* be applied to their instruments and accessories. Some compounds, such as gels, may be difficult to remove and can contain damaging particulates. If you think the use of such compounds is necessary, refer to the compound manufacturer for information on application and cleaning procedures.

Table 1-4. Cleaning Accessories

Item	HP Part Number
Isopropyl alcohol	8500-5344
Cotton swabs	8520-0023
Small foam swabs	9300-1223
Compressed dust remover (non-residue)	8500-5262

Table 1-5. Dust Caps Provided with Lightwave Instruments

Item	HP Part Number
Laser shutter cap	08145-64521
FC/PC dust cap	08154-44102
Biconic dust cap	08154-44105
DIN dust cap	5040-9364
HMS10/HP dust cap	5040-9361
ST dust cap	5040-9366

Inspecting Fiber-Optic Cables

Consistent measurements with your lightwave equipment are a good indication that you have good connections. However, you may wish to know the insertion loss and/or return loss of your lightwave cables or accessories. If you test your cables and accessories for insertion loss and return loss upon receipt, and retain the measured data for comparison, you will be able to tell in the future if any degradation has occurred.

Connector (or insertion) loss is one important performance characteristic of a lightwave connector. Typical values are less than 0.5 dB of loss, and sometimes as little as 0.1 dB of loss with high performance connectors. Return loss is another important factor. It is a measure of reflection: the less reflection the better (the larger the return loss, the smaller the reflection). The best physically contacting connectors have return losses better than 50 dB, although 30 to 40 dB is more common.

Visual inspection of fiber ends

Although it is *not necessary*, *visual inspection of fiber ends can be helpful*. Contamination or imperfections on the cable end face can be detected as well as cracks or chips in the fiber itself. Use a microscope (100X to 200X magnification) to inspect the entire end face for contamination, raised metal, or dents in the metal as well as any other imperfections. Inspect the fiber for cracks and chips. Visible imperfections not touching the fiber core may not affect performance (unless the imperfections keep the fibers from contacting).

To clean a non-lensed connector

CAUTION

Do not use any type of foam swab to clean optical fiber ends. Foam swabs can leave filmy deposits on fiber ends that can degrade performance.

- 1** Apply isopropyl alcohol to a clean lint-free cotton swab or lens paper.
Cotton swabs can be used as long as no cotton fibers remain on the fiber end after cleaning.
- 2** Before cleaning the fiber end, clean the ferrules and other parts of the connector.
- 3** Apply isopropyl alcohol to a new clean lint-free cotton swab or lens paper.
- 4** Clean the fiber end with the swab or lens paper. Move the swab or lens paper back and forth across the fiber end several times.

Some amount of wiping or mild scrubbing of the fiber end can help remove particles when application of alcohol alone will not remove them. This technique can remove or displace particles smaller than one micron.
- 5** Immediately dry the fiber end with a clean, dry, lint-free cotton swab or lens paper.
- 6** Blow across the connector end face from a distance of 6 to 8 inches using filtered, dry, compressed air. Aim the compressed air at a shallow angle to the fiber end face.

Nitrogen gas or compressed dust remover can also be used.

CAUTION

Do not shake, tip, or invert compressed air canisters, because this releases particles in the can into the air. Refer to instructions provided on the compressed air canister.

- 7** As soon as the connector is dry, connect or cover it for later use.

To clean an adapter

- 1 Apply isopropyl alcohol to a clean foam swab.

Cotton swabs can be used as long as no cotton fibers remain after cleaning. The foam swabs listed in this section's introduction are small enough to fit into adapters.

Although foam swabs can leave filmy deposits, these deposits are very thin, and the risk of other contamination buildup on the inside of adapters greatly outweighs the risk of contamination by foam swabs.

- 2 Clean the adapter with the foam swab.
- 3 Dry the inside of the adapter with a clean, dry, foam swab.
- 4 Blow through the adapter using filtered, dry, compressed air.

Nitrogen gas or compressed dust remover can also be used. Do not shake, tip, or invert compressed air canisters, because this releases particles in the can into the air. Refer to instructions provided on the compressed air canister.

To test insertion loss and return loss

To test insertion loss, use an appropriate lightwave source and a compatible lightwave receiver to test insertion loss. Examples of test equipment configurations include the following equipment:

- HP 71450B/51B/52B optical spectrum analyzers with Option 002 built-in white light source.
- HP 8702 or HP 8703 lightwave component analyzer system
- HP 83420 lightwave test set with an HP 8510 network analyzer
- HP 8153 lightwave multimeter with a source and power sensor module

To test return loss, use an appropriate lightwave source, a lightwave receiver, and lightwave coupler to test return loss. Examples of test equipment configurations include the following equipment:

- HP 8703 lightwave component analyzer
- HP 8702 analyzer with the appropriate source, receiver, and lightwave coupler
- HP 8504 precision reflectometer
- HP 8153 lightwave multimeter with a source and power sensor module in conjunction with a lightwave coupler
- HP 81554SM dual source and HP 81534A return loss module

Cleaning Electrical Connections

The following list includes the basic principles of microwave connector care. For more information on microwave connectors and connector care, consult the *Hewlett-Packard Microwave Connector Care Manual*, HP part number 08510-90064.

Handling and Storage

- Keep connectors clean
- Extend sleeve or connector nut
- Use plastic endcaps during storage
- Do *not* touch mating plane surfaces
- Do *not* set connectors contact-end down

Visual Inspection

- Inspect all connectors carefully before every connection
- Look for metal particles, scratches, and dents
- Do *not* use damaged connectors

Cleaning

- Try cleaning with compressed air first
- Clean the connector threads
- Do *not* use abrasives
- Do *not* get liquid onto the plastic support beads

Making Connections

- Align connectors carefully
- Make preliminary connection lightly
- To tighten, turn connector nut *only*
- Do *not* apply bending force to connection
- Do *not* overtighten preliminary connection
- Do *not* twist or screw in connectors
- Do *not* tighten past the “break” point of the torque wrench

Measuring Lightwave Sources

Measuring Lightwave Sources

In Chapter 1, “Getting Started”, you learned how to perform fast and easy measurements using the *guided setup* menus. In this chapter, you’ll learn how to perform source measurements manually for maximum measurement control. Examples of specific measurements are included. Additional measurement capabilities are available using display markers. To learn about these tools, refer to “Measuring with Markers” on page 7-1.

In this chapter, you’ll also learn how to change the sweep speed, increase dynamic range, and reduce trace noise.

Always perform error corrections

Before making a measurement, you must correct the test setup for any systematic errors at the current measurement settings. Refer to “Procedures for Error-Correcting Measurements” on page 13-21 for the procedures. These procedures require that calibration kits, which mathematically describe test setup components, be saved in the HP 8702D’s internal memory. Most of these calibration kits have already been loaded at the factory. To learn about calibration kits and defining lightwave standards, refer to Chapter 13, “Performing Calibrations”.

Measuring long electro-optical devices

The sweep time is the amount of time that it takes for the HP 8702D’s RF source to sweep from its start to its stop frequency. For normal measurements, the HP 8702D automatically sets the proper sweep time. However, when measuring a long electro-optical path, the HP 8702D’s sweep time should be lengthened. The sweep time must be long enough to allow the instrument to sample the modulation properly. In general, the sweep time should be set to a value equal to the number of measurement points times 15 ms. To verify that sweep time is long enough, increase it. If the overall shape of the trace remains the same, you can go back to the faster sweep, otherwise keep increasing the sweep time until the shape no longer changes.

What you'll find in this chapter

Making Transmission Measurements 2-4

To measure a source 2-5

Making Reflection Measurements 2-8

To measure electrical reflection from a source input 2-9

To measure optical reflection from a source output 2-12

Making Transmission Measurements

The examples in this section show you how to perform measurements on the following device type:

- Sources—electrical-to-optical (E/O) devices

Basic Measurement Sequence

Each measurement involves the following basic steps:

- 1** Press the PRESET key to return the HP 8702D to a known state.
- 2** Connect your test device to the HP 8702D.
- 3** Choose the settings that are appropriate for the intended measurement.
 - measurement type
 - frequencies
 - number of points
 - power
 - measurement sweep time
 - measurement sweep time (linear or logarithmic frequency)
 - measurement trace format
- 4** Make adjustments to the parameters while you view the device response.
- 5** Press the CAL key to perform a measurement calibration.

The calibration corrects errors using a known set of standards (a calibration kit). An error-correction establishes a magnitude and phase reference for the test setup and then reduces systematic measurement errors. Refer to “Types of error-correction” on page 13-18 for error-correction types.
- 6** Reconnect the device under test.
- 7** Use the markers to identify various device response values.
- 8** Store the measurement data to a disk.
- 9** Generate a hardcopy with a printer or plotter.

To measure a source

In this example, you will measure the modulation transfer characteristics of a source or E/O converter. This example is very similar to an O/E measurement.

Bandwidth, slope, responsivity (conversion of frequency), and flatness of an E/O device can be measured by performing a measurement calibration that uses the lightwave source cal data (model).

In general, transducers (E/O and O/E devices) are difficult to measure and often have to be measured in pairs, where the known response of one is used as a reference to measure the unknown response of another. Also, because the measurement system includes the HP lightwave receiver and lightwave source, optical and electrical cables, and the HP 8702D itself, a way must be found to separate the source response from the response of the system. This is where the HP 8702D differs from other measurement systems. It provides a way to make a measurement on a single transducer by the use of the HP 8702D error-correction feature.

When you insert your source (E/O) and have the calibration turned on (the annotation `Cor` appears on the display) the HP 8702D does two things:

- 1** It removes the entire system response (electrical and optical) using the measurement calibration data. This is similar to what you observed by performing a measurement calibration during the guided setup procedures.
- 2** It corrects the source (E/O) device under test response, using the HP source cal data (model) loaded into the HP 8702D. This is similar to comparing a known standard response to its measured response and correcting for any differences when device under test measurements are made.

When you replace the HP lightwave source with your own, the HP 8702D will measure the system response and apply the correction to the data. The result is an accuracy-enhanced measurement that describes the modulation transfer characteristics of your E/O device alone.

The HP 8702D can read the disk supplied with the lightwave source or receiver using its internal disk drive. The disk contains data points that characterize or model the lightwave source or receiver. The characterization can also be entered through the front panel by using the 9 numbers (coefficients) supplied on the label on the instrument.

Making Transmission Measurements

NOTE

The HP lightwave source RF input is a 50 Ω input that uses an SMA connector. Other connector types require electrical adapters.

- 1 Press PRESET on the HP 8702D.
- 2 Connect the test device to the HP 8702D as shown in Figure 2-1.

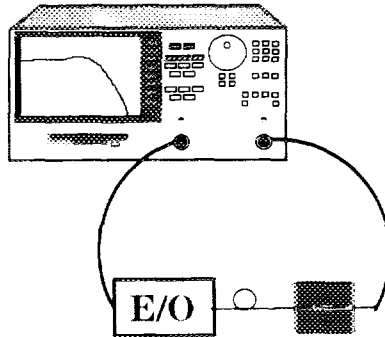

Figure 2-1. Connections for Source Measurement

- 3 Select the response settings appropriate for the device to be measured.
- 4 Press MEAS, *LIGHTWAVE PARAMETERS*, TRANS E/O (PORT 1 \rightarrow 2), START.
- 5 Enter the start frequency for the device being tested. In this example, you can leave the default frequency of 300 kHz to 3 GHz, or optionally 6 GHz.
- 6 Press STOP, and enter the stop frequency for the device being tested.
- 7 Press NUMBER of POINTS, and enter the number of points for the device being tested.
- 8 Press POWER, and enter the power for the device being tested. The maximum input power is 10 dBm.
- 9 Press MENU, SWEEP TIME, and increase the sweep time until you see no change in the display trace.
- 10 Press SWEEP TIME MENU, and select LIN FREQ to display the results linearly. Select LOG FREQ to display the results on a logarithmic display.

- 11** Press CAL to perform the measurement calibration. Refer to Chapter 13, "Performing Calibrations" for a complete description of the calibration procedures.
- 12** Reconnect the device under test.
- 13** After one complete sweep, the HP 8702D will display the response.
- 14** To display marker 1, press MARKER.
- 15** Use the knob to set the marker on a point of interest. Marker 1 displays the responsivity as a dB value. This can be calculated as:

$$Rs(dB) = 20 \log_{10} \frac{Rs(W/A)}{1(W/A)}$$

- 16** Press FORMAT, *LIN MAG*. Marker 1 displays the responsivity in watts/amp referenced to 1 watt/amp.
- 17** Refer to "Saving Measurement Data" on page 9-7 for information on saving the data.
- 18** Refer to "Printing or Plotting the Display" on page 12-5 for information on printing or plotting the data.

Making Reflection Measurements

The examples in this section show you how to perform the following measurements:

- Electrical reflection (impedance) from a source input
- Optical reflection from a source output

To measure electrical reflection from a source input

Electrical reflection measurements are important for matching the impedance of electrical inputs to electrical outputs. In order to separate the forward-going electrical signal from the reverse-traveling signal, an electrical signal separation device must be used. The integrated test set in the HP 8702D performs this signal separation.

A typical application in a fiber optic system would be to measure the electrical match of a source (E/O device). In many cases, this would be checking for a 50Ω impedance. For this example, you can measure the impedance of the lightwave source's RF input if you do not have another device under test.

The amount of power reflected from a device is directly related to the impedances of both the device and the measuring system. In fact, each value of the reflection coefficient uniquely defines a device impedance. A reflection coefficient of zero only occurs when the device under test and the measuring system test set impedance are exactly the same value; in other words, there is no power reflected. A short circuit has a reflection coefficient of 1 at ±180 degrees. This is because all of the incident power is reflected back 180 degrees out of phase. Every other value of reflection coefficient also corresponds uniquely to a complex device impedance according to the following equations:

$$Z_n = \frac{Z_{DUT}}{Z_0}$$

or,

$$Z_n = \frac{1 + \text{Reflection Coefficient}}{1 - \text{Reflection Coefficient}}$$

where Z_n is the device under test impedance normalized to (divided by) the measuring system's characteristic impedance.

Making Reflection Measurements

In electrical RF measurements, a special display called a Smith chart is used to read the impedance data in the $R+jX$ format, where R is the resistive component and jX is the reactive (capacitive or inductive) component. The HP 8702D generates this display as a Smith chart overlaid on a polar coordinate chart.

The following example shows how to make an electrical calibration and measure the reflection coefficient of a simulated source (E/O converter) electrical input. The HP 8702D will respond by displaying the data as a ratio of the reflected signal compared to the incident signal.

NOTE

When using an HP 8702D Option 011, an HP test set such as an HP 85046A or HP 85047A is required. Also, an HP calibration kit, with electrical standards (short, open, load) in the connector type of your device under test, is required. In order to measure the electrical input of the SMA RF input to the lightwave source, a 3.5 mm calibration kit and a 7 mm to 3.5 mm adapter is required. The 3.5 mm adapter is compatible with and will adapt easily to SMA.

- 1 Press PRESET.
- 2 Connect the equipment as shown in Figure 2-2.

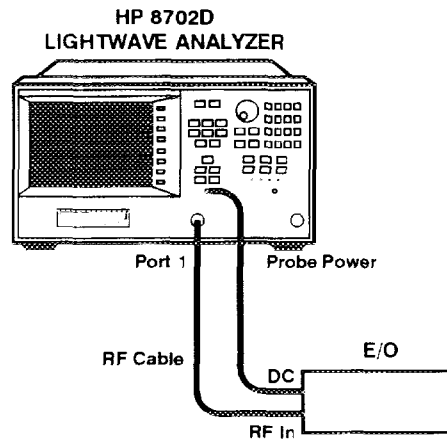

Figure 2-2. Electrical Reflection Configuration

Callr

- 3** Press MEAS, *Refl: E S11 FWD*. Use the default frequency settings, 300 kHz to 3 GHz, or optionally 6 GHz.
- 4** Press FORMAT, *SMITH CHART*.
- 5** Perform an electrical measurement calibration. This is an S11 1-port calibration.
 - a** Press CAL, *CAL KITS & STDS, SELECT CAL KIT, 3.5mmD* (or whatever is appropriate for your measurement.)
 - b** Press RETURN, RETURN, *CALIBRATE MENU, S11 1-PORT*.
 - c** Connect open to cable on port 1, then press *FORWARD OPEN*.
 - d** Connect short to cable on port 1, then press *FORWARD SHORT*.
 - e** Connect load to cable on port 1, then press *FORWARD LOAD*.
 - f** Press *DONE 1-PORT CAL*.

After one sweep, the analyzer will be measuring the electrical reflection on Port 1.
 - g** Connect the source to be tested to Port 1.

To measure optical reflection from a source output

- 1 Press **PRESET**.

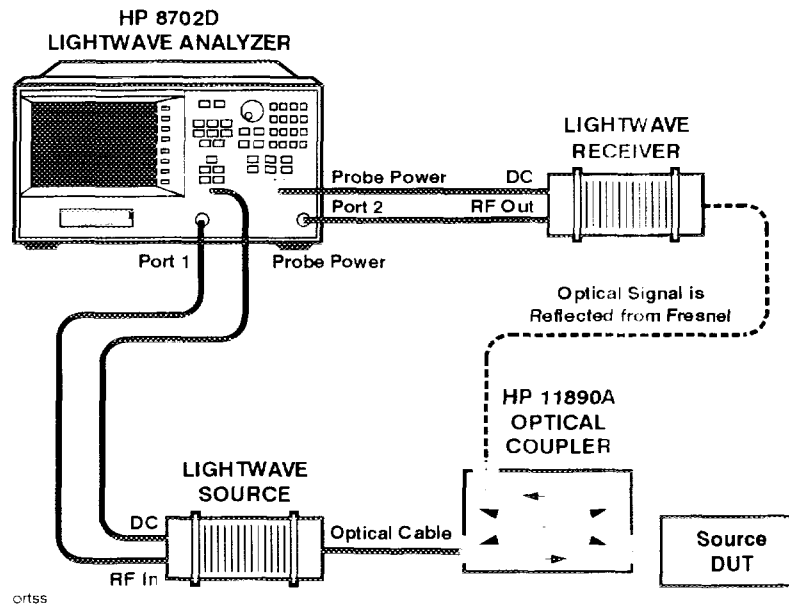

Figure 2-3. Optical Reflection Test Setup

- 2 Press **AVG**, *IF BW*, 100, x1.
- 3 Press **MENU**, *SWEEP TIME*, 3.5, x1.
- 4 Press **POWER**, 10, x1.
- 5 Press **MEAS**, *LIGHTWAVE PARAMETERS*, *Refl: 0 (PORT 1→2)*.
- 6 Remove the device being tested from the optical coupler. Leave the output of the coupler unterminated so that a Fresnel response is produced.

WARNING

Do not look into the coupler's output or any fiber/device attached to the output while the laser is in operation.

- 7 Press **CAL**, *CAL KITS & STDS*, *OPTICAL STANDARDS*, *DEFAULT STANDARDS*, *RETURN*, *RETURN*, *CALIBRATE MENU*, *RESPONSE*, *FRESNEL*.
- 8 Press **SAVE/RECALL** to save the calibration.

- 9 Connect the source under test to the coupler input/output.

Measuring Lightwave Sources
Making Reflection Measurements



Measuring Lightwave Receivers

Measuring Lightwave Receivers

In Chapter 1, “Getting Started”, you learned how to perform fast and easy measurements using the *guided setup* menus. In this chapter, you’ll learn how to perform receiver measurements manually for maximum measurement control. Examples of specific measurements are included. Additional measurement capabilities are available using display markers. To learn about these tools, refer to “Measuring with Markers” on page 7-1.

In this chapter, you’ll also learn how to change the sweep speed, increase dynamic range, and reduce trace noise.

Always perform error corrections

Before making a measurement, you must correct the test setup for any systematic errors at the current measurement settings. Refer to “Procedures for Error-Correcting Measurements” on page 13-21 for the procedures. These procedures require that calibration kits, which mathematically describe test setup components, be saved in the HP 8702D’s internal memory. Most of these calibration kits have already been loaded at the factory. To learn about calibration kits and defining lightwave standards, refer to Chapter 13, “Performing Calibrations”.

Measuring long electro-optical devices

The sweep time is the amount of time that it takes for the HP 8702D’s RF source to sweep from its start to its stop frequency. For normal measurements, the HP 8702D automatically sets the proper sweep time. However, when measuring a long electro-optical path, the HP 8702D’s sweep time should be lengthened. The sweep time must be long enough to allow the instrument to sample the modulation properly. In general, the sweep time should be set to a value equal to the number of measurement points times 15 ms.

Isolate the lightwave source

Avoid measuring devices that reflect greater than approximately -14 dBm back into the laser, because the laser is sensitive to reflections. If necessary, use a well-matched optical attenuator between the laser source and the test

device. Or, use an optical isolator to minimize or eliminate the laser sources reflection sensitivity response. Whenever possible, use optically isolated lightwave sources with low optical reflections (RL >35 dB) to minimize effects of reflection sensitivity and to maximize measurement repeatability and accuracy.

What you'll find in this chapter

Making Transmission Measurements 3-4

 To measure a receiver 3-5

Making Reflection Measurements 3-8

 To measure optical reflection from a receiver input 3-9

 To measure electrical reflection from a receiver output 3-10

Measuring Phase Distortion 3-11

Making Transmission Measurements

The examples in this section show you how to perform measurements on the following device type:

- Receivers—optical-to-electrical (O/E) devices

Basic Measurement Sequence

Each measurement involves the following basic steps:

- 1** Press the PRESET key to return the HP 8702D to a known state.
- 2** Connect your test device to the HP 8702D.
- 3** Choose the settings that are appropriate for the intended measurement.
 - measurement type
 - frequencies
 - number of points
 - power
 - measurement sweep time
 - measurement sweep type (linear or logarithmic frequency)
 - measurement trace format
- 4** Make adjustments to the parameters while you view the device response.
- 5** Press the CAL key to perform a measurement calibration.

The calibration corrects errors using a known set of standards. An error-correction establishes a magnitude and phase reference for the test setup and then reduces systematic measurement errors. Refer to “Types of error-correction” on page 13-18 for error correction types.
- 6** Reconnect the device under test.
- 7** Use the markers to identify various device response values.
- 8** Store the measurement data to a disk.
- 9** Generate a hardcopy with a printer or plotter.

To measure a receiver

In this example, you will measure the modulation transfer characteristics of a receiver or O/E converter. This example is very similar to an E/O measurement.

Bandwidth, responsivity, and flatness of an O/E device can be measured by performing a measurement calibration that uses the lightwave receiver cal data (model).

In general, transducers (O/E and E/O devices) are difficult to measure and often have to be measured in pairs, where the known response of one is used as a reference to measure the unknown response of another. Also, because the measurement system includes the HP lightwave receiver and lightwave source, optical and electrical cables, and the HP 8702D itself, a way must be found to separate the receiver response from the response of the system. This is where the HP 8702D differs from other measurement systems. It provides a way to make a measurement on a single transducer by the use of the HP 8702D error-correction feature.

When you insert your receiver (O/E) and have the calibration turned on (the annotation `Cor` appears on the display) the HP 8702D does two things:

- 1** It removes the entire system response (electrical and optical) using the measurement calibration data. This is similar to what you observed by performing a measurement calibration during the guided setup procedures.
- 2** It corrects the receiver (O/E) device under test response, using the HP receiver cal data (model) loaded into the HP 8702D. This is similar to comparing a known standard response to its measured response and correcting for any differences when device under test measurements are made.

When you replace the HP lightwave receiver with your own, the HP 8702D will measure the system response and apply the correction to the data. The result is an accuracy-enhanced measurement that describes the modulation transfer characteristics of your O/E device alone.

The HP 8702D can read the disk supplied with the lightwave source or receiver using its internal disk drive. The disk contains data points that characterize or model the lightwave source or receiver. The characterization can also be entered through the front panel by using the 9 numbers (coefficients) supplied on the label on the instrument.

Making Transmission Measurements

NOTE

The HP lightwave source RF input is a 50Ω input that uses an SMA connector. Other connector types require electrical adapters.

- 1 Press PRESET.
- 2 Connect the test device to the HP 8702D as shown in Figure 3-1.

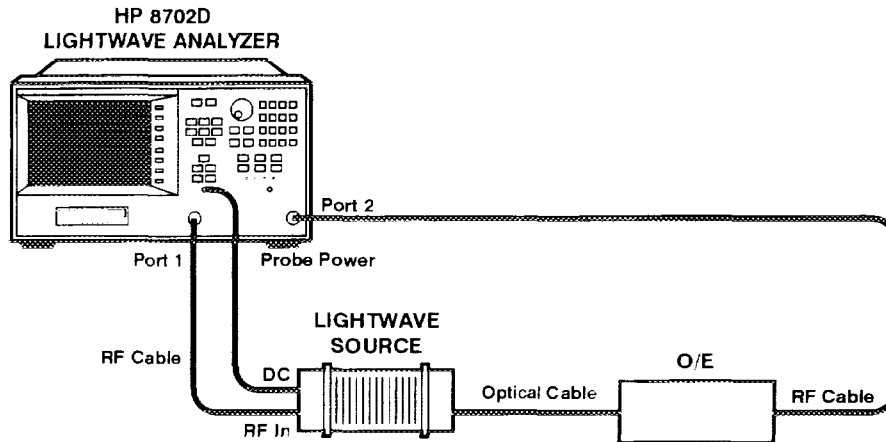

Circ

Figure 3-1. Connections for Receiver Response Calibration

- 3 Select the response settings appropriate for the device to be measured.
- 4 Press MEAS, *LIGHTWAVE PARAMETERS*, *Trans: O/E (PORT 1→2)*.
- 5 Press START, then enter the start frequency for the device being tested. In this example, you can leave the default frequency of 300 kHz to 3 GHz (optionally 6 GHz).
- 6 Press STOP, then enter the stop frequency for the device being tested.
- 7 Press *NUMBER of POINTS*.
- 8 Press *POWER*, then enter the power level. The maximum input power is 10 dBm.
- 9 Press MENU, *SWEEP TIME*. Increase the sweep time until you see no change in the display trace.

- 10** Press *SWEEP TIME MENU*.
 - a** Select *LIN FREQ* to display the results linearly.
 - b** Select *LOG FREQ* to display the results on a logarithmic display.
- 11** Press *CAL* to perform the measurement calibration. Refer to Chapter 13, "Performing Calibrations" for a complete description of the calibration procedures.
- 12** Reconnect the device under test.
- 13** After one complete sweep, the HP 8702D will display the response.
- 14** To display marker 1, press *MARKER*. Use the front-panel knob to set the marker on a point of interest. Marker 1 display the responsivity as a dB value. This can be calculated as:

$$R_R = 20 \log_{10} \frac{R_R(A/W)}{I(A/W)}$$

- 15** Press *FORMAT, LIN MAG*. Marker 1 displays the responsivity in amps/watts referenced to 1 amp/watts.
- 16** Refer to Chapter 9, "Saving Data, States, and the Display" for information on saving the data.
- 17** Refer to Chapter 12, "Printing and Plotting" for information on printing or plotting the data.

Making Reflection Measurements

The examples in this section show you how to perform the following measurements:

- Optical reflection from a receiver input to an optical-to-electrical (O/E) device
- Electrical reflection from a receiver output

To measure optical reflection from a receiver input

- 1 Press PRESET.

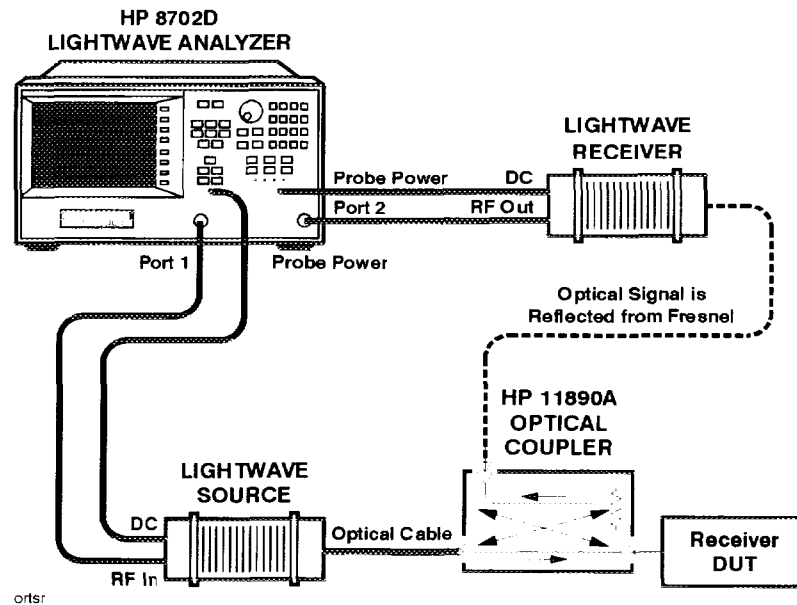

Figure 3-2. Optical Reflection Test Setup

- 2 Press AVG, *IF BW*, 100, x1.
- 3 Press MENU, *SWEEP TIME*, 3.5, x1, *POWER*, 10, x1
- 4 Press MEAS, *LIGHTWAVE PARAMETERS*, *Ref1: 0 (PORT 1→2)*
- 5 Remove the device being tested from the optical coupler. Leave the output of the coupler unterminated so that a Fresnel response is produced.

WARNING

Do not look into the coupler's output or any fiber/device attached to the output while the laser is in operation.

- 6 Press CAL, *CAL KITS & STDS*, *OPTICAL STANDARDS*, *DEFAULT STANDARDS*, RETURN, RETURN, CALIBRATE MENU, RESPONSE, FRESNEL
- 7 Press SAVE/RECALL to save the calibration.
- 8 Connect the receiver under test to the coupler input/output.

To measure electrical reflection from a receiver output

- 1 Press PRESET.

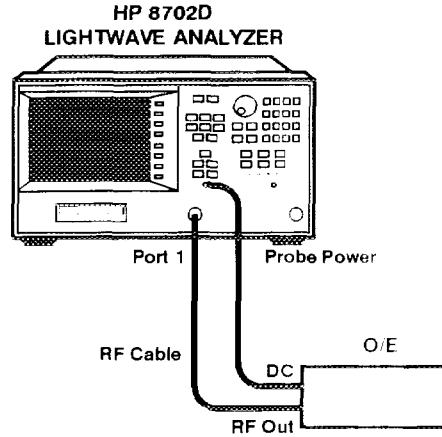

Callw

Figure 3-3. Connections for Electrical Reflection Calibration

- 2 Press MEAS, *Ref: E S22 REV*. Use the default frequency settings, 300 kHz to 3 GHz, or optionally 6 GHz.
- 3 Press FORMAT, *SMITH CHART*.
- 4 Perform an electrical measurement calibration (this is an S22 1-port calibration) by pressing:
 - a CAL, *CAL KITS & STDS, SELECT CAL KIT, 3.5mmD* (or whatever is appropriate for your measurement).
 - b RETURN, RETURN, *CALIBRATE MENU, S22 1-PORT*.
 - c Connect open to cable on Port 2, then press *REVERSE OPEN*.
 - d Connect short to cable on Port 2, then press *REVERSE SHORT*.
 - e Connect load to cable on Port 2, then press *REVERSE LOAD*.
 - f Press *DONE 1-PORT CAL*.

After one sweep, the analyzer will be measuring the electrical reflection on Port 2.

- 5 Connect the receiver to be tested to Port 2.

Measuring Phase Distortion

A digital communication system is often limited by the amount of distortion that occurs. This distortion increases the bit error rate and can also distort the transmitted data. Although distortion can be caused by the fiber, it is usually associated with the system components such as O/E receivers, amplifiers, and other devices in the transmission path.

The analyzer can display phase distortion as either deviation from linear phase or group delay. The measurement is essentially a transmission measurement displayed in the phase format. With electrical delay mathematically added to the device under test response, the transmit time through the device under test and its deviation from linear phase can be determined.

In this example, an O/E (non-amplified photodiode) device under test is used to demonstrate how the analyzer can measure deviation from linear phase and delay (transmit time) through the device. To do this, the receiver CAL DATA disk is used to perform the transmission calibration.

- 1 Connect the system as shown in Figure 3-4.

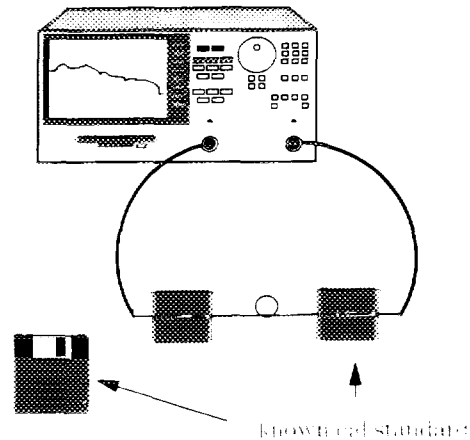

Figure 3-4. Phase Distortion CAL Test Setup

- 2 Select the measurement parameters and perform a response calibration.

```
PRESET, MEAS, LIGHTWAVE PARAMETERS, Trans: O/E (PORT 1→2)  
AVG, IF BW, 100, x1  
MENU, POWER, 10, x1, RETURN  
STOP, 2, G/n
```

The IF bandwidth is decreased to reduce the effects of noise, the power is increased to +10 dBm to get better dynamic range, and the modulation stop frequency is set just about the device under test's bandwidth.

- 3 Load the receiver CAL DATA from the disk into the analyzer by pressing:

```
CAL, CAL KITS & STDS, RECEIVER STANDARDS, LOAD RCVR DISC MENU
```

Be sure the file title matches the serial number of the receiver and then press the corresponding softkey, *LOAD RCVR1 DISK* or *LOAD RCVR2 DISK*, and wait until the files have been loaded.

- 4 Perform the calibration by pressing: CAL, CALIBRATE MENU, RESPONSE, DISK(1) or DISK(2).
- 5 To save the data, press SAVE/RECALL, SAVE STATE.
- 6 Select the phase format to view the calibrated phase response of the receiver

by pressing:

FORMAT, PHASE

The display should look similar to Figure 3-5, except for the markers. The markers on the example plot help to explain how phase is displayed on the analyzer. Note that the X-axis is the modulation frequency range and the Y-axis is phase, set to 90 degrees per division:

Marker 1 is at 0 degrees, marker 2 is at -180 degrees, marker 3 is near +180 degrees, and marker 4 is near 0 degrees (-3.1778 degrees). Better resolution can be obtained by increasing the number of points.

You can set the marker to any frequency and read the phase shift for that frequency on the display.

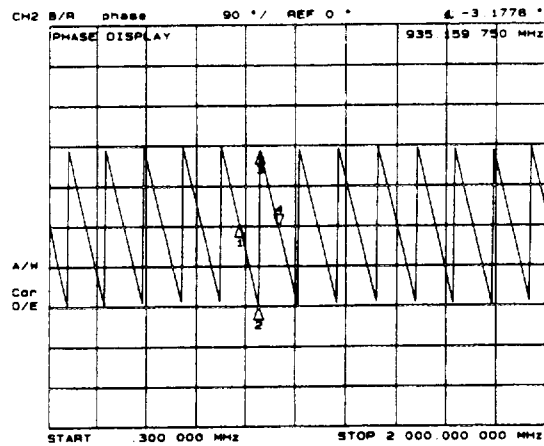

Figure 3-5. Calibrated Receiver System Phase Response

Measuring Lightwave Receivers
Measuring Phase Distortion

- 7 Insert the O/E device under test into the system in place of the receiver. Figure 3-6 shows the phase response of the diode receiver.

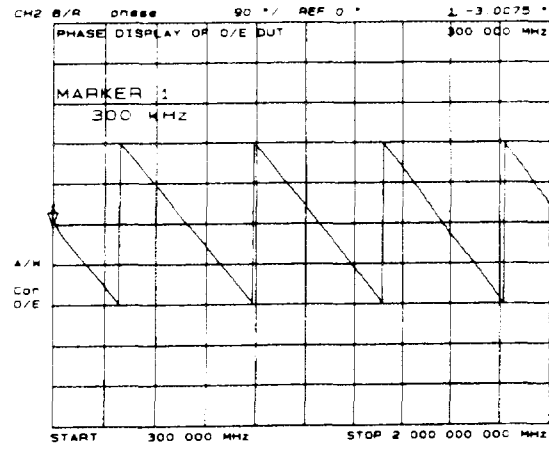

Figure 3-6. Phase Response of O/E (photo diode) Device Under Test

- 8 To measure the electrical delay or transmit time through the device under test, you must add enough electrical length or delay to the device to flatten out the phase response as close to zero degrees as possible. Adding electrical delay is a mathematical function that attempts to remove the length of the device by adding the delay to the measurement data. Press:

SCALE REF, *ELECTRICAL DELAY*, then rotate (clockwise) the front panel knob until the trace is as flat as possible, similar to Figure 3-7.

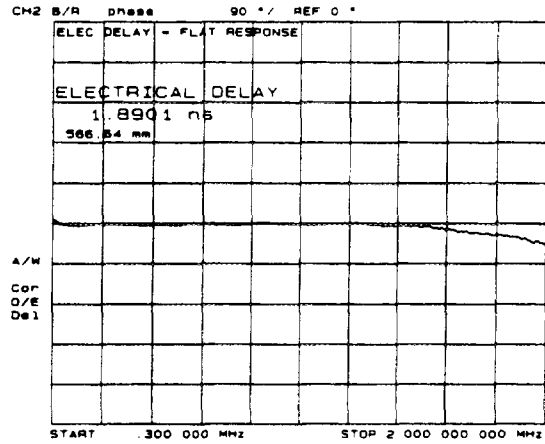

Figure 3-7. Electrical Delay Used to Flatten Phase Response

9 Obtain great resolution by pressing:

SCALE REF, SCALE/DIV, 10, x1

If necessary, readjust *ELECTRICAL DELAY* so that the trace is as flat as possible across most of the band. Figure 3-8 shows an electrical transit time of 1.886 ns through the device under test. In this example, about 6 degrees of deviation from linear phase are shown across the band within the markers, approximately 1.56 MHz. To view the deviation at any particular modulation frequency, simply put the marker on that value and read the display.

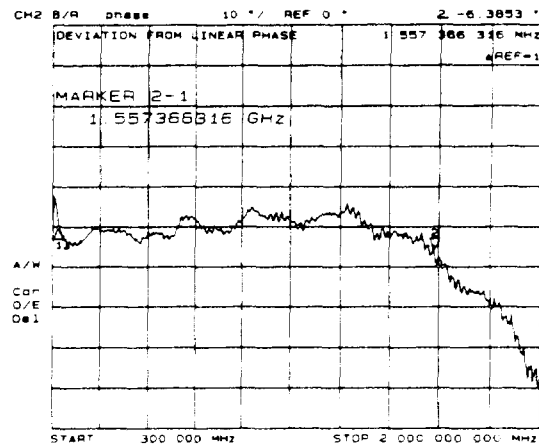

Figure 3-8. Deviation from Linear Phase of O/E Device Under Test (Diode)

Measuring Electrical Devices

Measuring Electrical Devices

Always perform error corrections

Before making a measurement, you must correct the test setup for any systematic errors at the current measurement settings. Refer to “Procedures for Error-Correcting Measurements” on page 13-21 for the procedures. These procedures require that calibration kits, which mathematically describe test setup components, be saved in the HP 8702D’s internal memory. Most of these calibration kits have already been loaded at the factory. To learn about calibration kits, refer to Chapter 13, “Performing Calibrations”.

What you'll find in this chapter

Measuring Magnitude and Insertion Phase Response	4-4
Measuring Electrical Length and Phase Distortion	4-9
Performing Time Domain Measurements	4-22
Reducing Receiver Crosstalk	4-30
Amplifier Testing	4-31
Performing Swept Power Measurements	4-35
Measuring Gain Compression	4-36
Measuring Gain and Reverse Isolation Simultaneously	4-40
Performing Harmonic Measurements (Option 002)	4-42
Mixer Testing	4-46
Performing On-Wafer Measurements	4-62
Connection Considerations	4-63

Measuring Magnitude and Insertion Phase Response

The HP 8702D allows you to make two different measurements simultaneously. You can make these measurements in different formats for the same parameter. For example, you could measure both the magnitude and phase of transmission. You could also measure two different parameters (S_{11} and S_{22}).

To measure the magnitude and phase response

- 1 Connect your test device as shown in Figure 4-1.

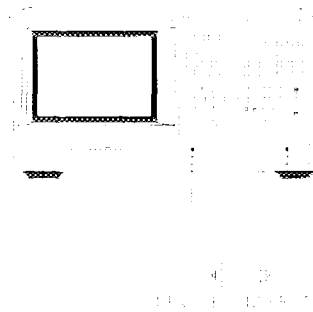

Figure 4-1. Device Connections for Measuring a Magnitude Response

- 2 Press PRESET and choose the measurement settings. For this example, the measurement settings are as follows:

MEAS, *Trans: E/E S21 FWD*
CENTER, 134, M/ μ
SPAN, 50, M/ μ
MENU, *POWER*, -3, x1
SCALE REF, *AUTO SCALE*
CHAN 2
MEAS, *Trans: E/E S21 FWD*
SCALE REF, *AUTO SCALE*

You may also want to select settings for the number of data points, averaging, and IF bandwidth.

- 3 Substitute a thru for the device and perform a frequency response measurement correction for both channel 1 and channel 2.
- 4 Reconnect your test device.
- 5 To better view the measurement trace, press:
CHAN 1, SCALE REF, *AUTO SCALE*
- 6 To locate the maximum amplitude of the device response, as shown in Figure 4-2, press:
MARKER FCTN, *MKR SEARCH*, *SEARCH: MAX*

Measuring Magnitude and Insertion Phase Response

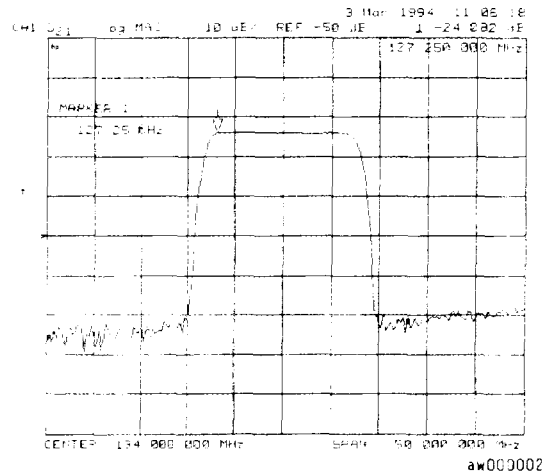

Figure 4-2. Example Magnitude Response Measurement Results

- 7 To view both the magnitude and phase response of the device, as shown in Figure 4-3, press:

CHAN 2
 DISPLAY, *DUAL CHAN ON*
 FORMAT, *PHASE*

The channel 2 portion of Figure 4-3 shows the insertion phase response of the device under test. The analyzer measures and displays phase over the range of -180° to $+180^\circ$. As phase changes beyond these values, a sharp 360° transition occurs in the displayed data.

The phase response shown in Figure 4-4 is undersampled; that is, there is more than 180° phase delay between frequency points. The frequency span should be reduced, or the number of points increased until $\Delta\phi$ is less than 180° per point. Electrical delay may also be used to compensate for this effect.

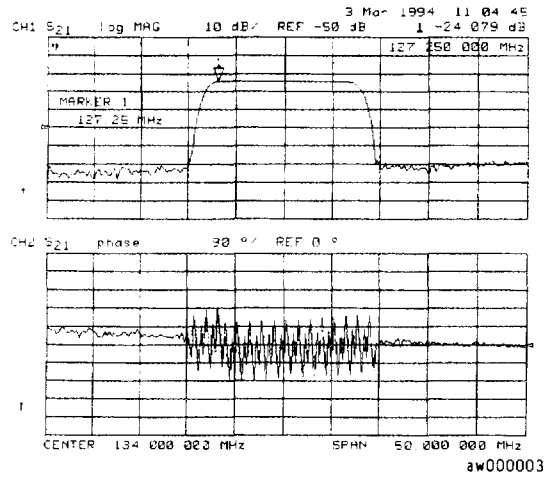

Figure 4-3. Example Insertion Phase Response Measurement

Measuring Magnitude and Insertion Phase Response

If the $\Delta\phi = >180^\circ$, incorrect phase and delay information may result. The responses shown in Figure 4-3 have a $\Delta\phi = >180^\circ$ between two adjacent frequency points. Figure 4-4 shows an example of phase samples with $\Delta\phi$ less than 180° and greater than 180° .

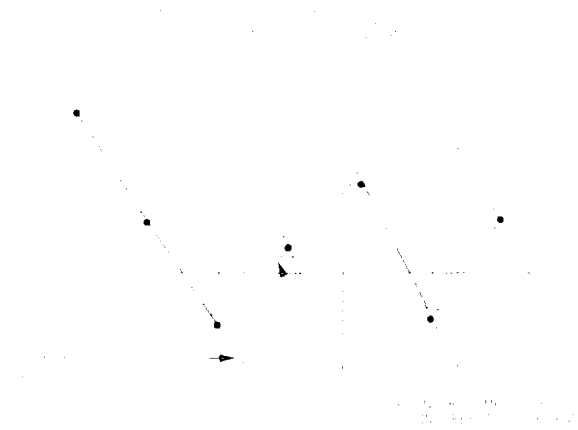

Figure 4-4. Maximum Amplitude of SAW Filter in Phase Format

Measuring Electrical Length and Phase Distortion

Measure changing phase by adding electrical delay

Electrical delay simulates a variable length lossless transmission line, which you can add to or remove from the HP 8702D's receiver input to compensate for devices such as interconnecting cables.

Linearly changing phase is due to a device's electrical length. You can measure this changing phase by adding electrical length (electrical delay) to compensate for it. A marker-to-delay function can be used to calculate the electrical delay by taking a $\pm 10\%$ span about the marker, measuring the $\Delta\phi$, and computing the delay as $\Delta\phi/\Delta$ frequency.

The measurement value that the HP 8702D displays represents the electrical length of your device relative to the speed of light in free space. The physical length of your device is related to this value by the propagation velocity of its medium. You could use the *VELOCITY FACTOR* softkey function to change the velocity factor to compensate for propagation velocity, helping the HP 8702D to measure correctly.

Phase distortion

The HP 8702D allows you to measure the linearity of the phase shift through a device over a range of frequencies and the HP 8702D can express it in two different ways: deviation from linear phase or group delay.

By adding electrical length to "flatten out" the phase response, you have removed the linear phase shift through your device. The deviation from linear phase shift through your device is all that remains. Refer to Figure 4-10.

Group delay

The phase linearity of many devices is specified in terms of group or envelope delay. The HP 8702D can translate phase distortion into a related parameter, group delay. Group delay is the transmission time through your device as a function of frequency. Mathematically, it is the derivative of the phase response which can be approximated by the following ratio:

$$\Delta\phi / (360 * \Delta F)$$

where $\Delta\phi$ is the difference in phase at two frequencies separated by ΔF .

The quantity ΔF is commonly called the "aperture" of the measurement. The HP 8702D calculates group delay from its phase response measurements. The default aperture is the total frequency span divided by the number of points across the display (in this example, 201 points or 0.5% of the total span).

Group delay principles

For many networks, the amount of insertion phase is not as important as the linearity of the phase shift over a range of frequencies. The analyzer can measure this linearity and express it in two different ways: directly, as deviation from linear phase, or as group delay, a derived value.

Group delay is the measurement of signal transmission time through a test device. It is defined as the derivative of the phase characteristic with respect to frequency. Since the derivative is basically the instantaneous slope (or rate of change of phase with respect to frequency), a perfectly linear phase shift results in a constant slope, and therefore a constant group delay (refer to Figure 4-5).

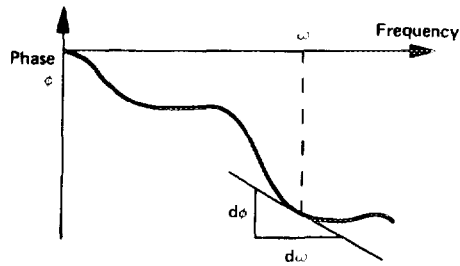

pg6182_c

Figure 4-5. Constant Group Delay

Measuring Electrical Length and Phase Distortion

Note, however, that the phase characteristic typically consists of both linear and higher order (deviations from linear) components. The linear component can be attributed to the electrical length of the test device, and represents the average signal transit time. The higher order components are interpreted as variations in transit time for different frequencies, and represent a source of signal distortion (refer to Figure 4-6).

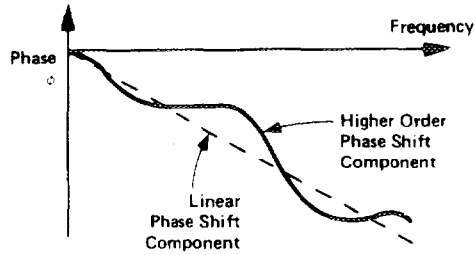

$$\text{Group Delay} = \tau_g = \frac{-d\phi}{d\omega} \quad \begin{array}{l} \phi \text{ in Radians} \\ \omega \text{ in Radians} \end{array}$$

$$= \frac{-1}{360^\circ} \cdot \frac{d\phi}{df} \quad \begin{array}{l} \phi \text{ in Degrees} \\ f \text{ in Hz } (\omega = 2\pi f) \end{array}$$

pg6183 c

Figure 4-6. Higher Order Phase Shift

The analyzer computes group delay from the phase slope. Phase data is used to find the phase change, $\Delta\phi$, over a specified frequency aperture, Δf , to obtain an approximation for the rate of change of phase with frequency (refer to Figure 4-7). This value, τ_g , represents the group delay in seconds assuming linear phase change over Δf . It is important that $\Delta\phi$ be $\leq 180^\circ$, or errors will result in the group delay data. These errors can be significant for long delay devices. You can verify that $\Delta\phi$ is $\leq 180^\circ$ by increasing the number of points or narrowing the frequency span (or both) until the group delay data no longer changes.

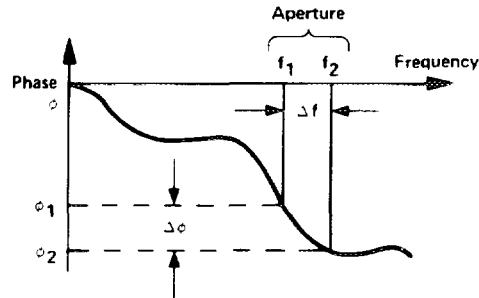

pg6180_c

Figure 4-7. Rate of Phase Change Versus Frequency

Measuring Electrical Length and Phase Distortion

When deviations from linear phase are present, changing the frequency step can result in different values for group delay. Note that in this case the computed slope varies as the aperture Δf is increased (refer to Figure 4-8). A wider aperture results in loss of the fine grain variations in group delay. This loss of detail is the reason that, in any comparison of group delay data, it is important to know the aperture used to make the measurement.

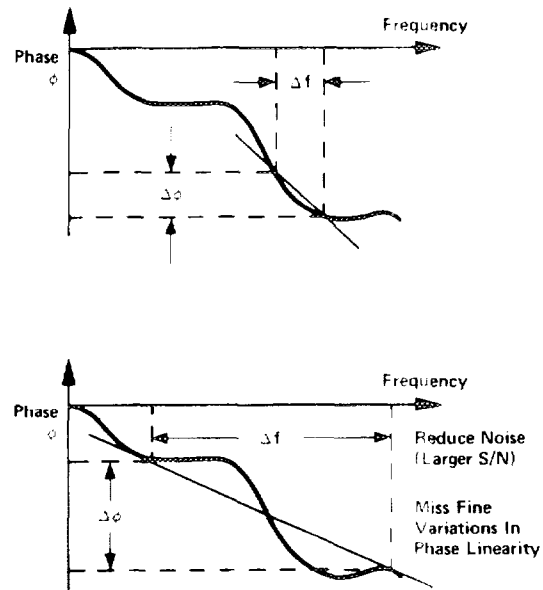

pg6181 c

Figure 4-8. Variations in Frequency Aperture

In determining the group delay aperture, there is a trade-off between resolution of fine detail and the effects of noise. Noise can be reduced by increasing the aperture, but this will tend to smooth out the fine detail. More detail will become visible as the aperture is decreased, but the noise will also increase, possibly to the point of obscuring the detail. A good practice is to use a smaller aperture to assure that small variations are not missed, then increase the aperture to smooth the trace.

The default group delay aperture is the frequency span divided by the number of points across the display. To set the aperture to a different value, turn on smoothing in the average menu, and vary the smoothing aperture. The aperture can be varied up to 20% of the span swept.

Group delay measurements can be made on linear frequency, log frequency, or list frequency sweep types (not in CW or power sweep). Group delay aperture varies depending on the frequency spacing and point density, therefore the aperture is not constant in log and list frequency sweep modes. In list frequency mode, extra frequency points can be defined to ensure the desired aperture.

To obtain a readout of aperture values at different points on the trace, turn on a marker. Then press **AVG**, **SMOOTHING APERTURE**. Smoothing aperture becomes the active function, and as the aperture is varied its value in Hz is displayed below the active entry area.

Electrical delay

The **ELECTRICAL DELAY** softkey, which is accessible from the **SCALE REF** key, adjusts the electrical delay to balance the phase of the test device. It simulates a variable length lossless transmission line, which can be added to or removed from a receiver input to compensate for interconnecting cables, etc. This function is similar to the mechanical or analog "line stretchers" of other analyzers. Delay is annotated in units of time with secondary labeling in distance for the current velocity factor.

With this feature, and with **MARKER** → **DELAY**, an equivalent length of air-filled, lossless transmission line is added or subtracted according to the following formula:

$$\text{Length (meters)} = \phi / (\text{Freq in MHz} \times 1.20083)$$

Once the linear portion of the test device's phase has been removed, the equivalent length of the lossless transmission line can be read out in the active marker area. If the average relative permittivity (ϵ_r) of the test device is known over the frequency span, the length calculation can be adjusted to indicate the actual length of the test device more closely. This can be done by entering the relative velocity factor for the test device using the calibrate more menu. The relative velocity factor for a given dielectric can be calculated by:

$$\text{Velocity Factor} = 1 + \text{square root of } \epsilon_r \text{ (assuming a relative permeability of 1)}$$

To measure electrical length

- 1 Connect your test device as shown in Figure 4-9.

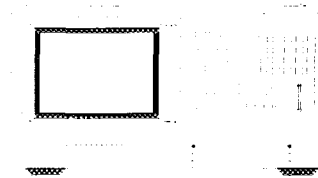

Figure 4-9. Device Connections for Measuring Electrical Length

- 2 Press PRESET and choose the measurement settings. For example, press:
MEAS, *Trans: E/E S21 FWD*
CENTER, 134, M/ μ
SPAN, 2, M/ μ
MENU, *POWER*, 5, x1
FORMAT, *PHASE*
SCALE REF, *AUTO SCALE*
- 3 Substitute a thru for the device and perform a frequency response measurement correction.
- 4 Reconnect your test device.
- 5 To better view the measurement trace, press SCALE REF, *AUTO SCALE*.
You may need to make the frequency span wider to see the effects of phase shift.

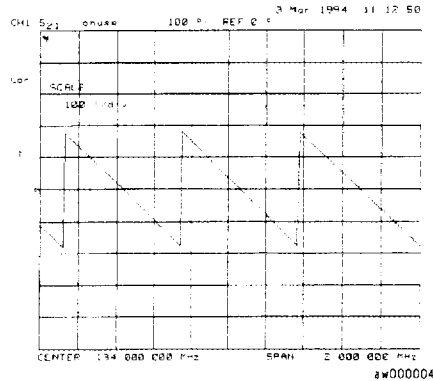

Figure 4-10. Linearly Changing Phase

- 6 Press MARKER and turn the front panel knob.
- 7 Press MARKER FCTN, *MARKER*→*DELAY*.
- 8 Turn the front panel knob to increase the electrical length until you achieve the best flat line, as shown in Figure 4-11.
- 9 If you know the velocity factor, press CAL, *MORE*, *VELOCITY FACTOR* and enter the value, followed by x1.

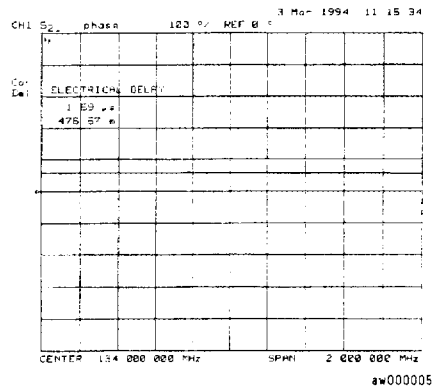

Figure 4-11. Example Best Flat Line with Added Electrical Delay

- 10 To display the electrical length, press SCALE REF, *ELECTRICAL DELAY*.

To measure phase distortion

- 1 Follow the procedure in "To measure electrical length" on page 4-16.
- 2 Press SCALE REF, *SCALE DIV* and turn the front panel knob to increase the scale resolution.
- 3 To use the marker statistics to measure the maximum peak-to-peak deviation from linear phase, press MARKER FCTN, *MARKER MODE MENU*, *STATS ON*.
- 4 Activate and adjust the electrical delay to obtain a minimum peak-to-peak value.

It is possible to use delta markers to measure peak-to-peak deviation in only one portion of the trace, refer to "To calculate the statistics of the measurement data" on page 7-29.

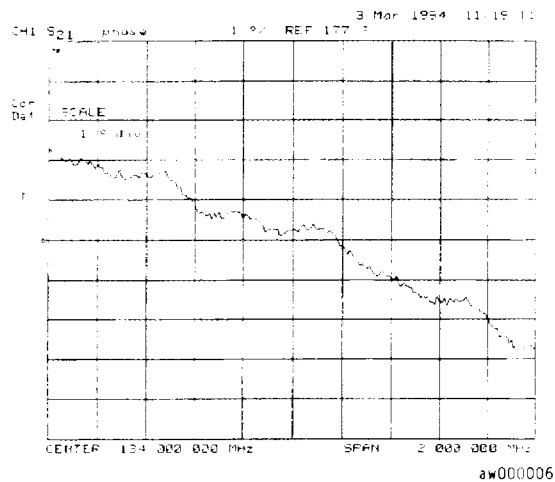

Figure 4-12. Deviation From Linear Phase Example Measurement

To measure group delay

- 1 Perform the procedure "To measure phase distortion" on page 4-18.
- 2 Press **FORMAT**, **DELAY**, **SCALE REF**, **SCALE DIV**, \uparrow , \uparrow .
- 3 To activate a marker to measure the group delay at a particular frequency, press **MARKER** and turn the front panel knob.

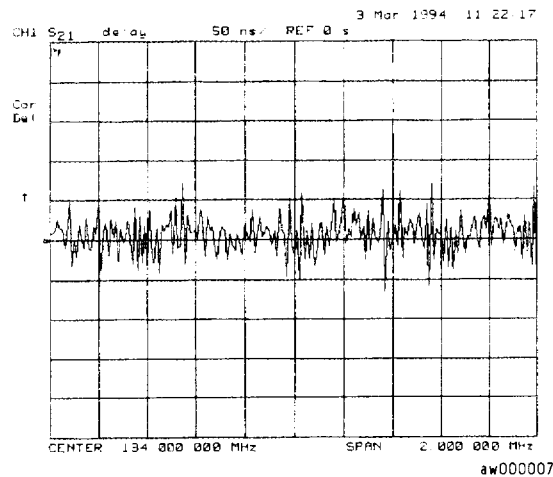

Figure 4-13. Group Delay Example Measurement

- 4 To vary the effective group delay aperture from minimum aperture (no smoothing) to approximately 1% of the frequency span, press **AVG**, **SMOOTHING ON**.

Group delay measurements may require a specific aperture (Δf) or frequency spacing between measurement points. The phase shift between two adjacent frequency points must be less than 180° , otherwise incorrect group delay information may result. When you increase the aperture, the HP 8702D removes fine grain variations from the response. It is critical that you specify the group delay aperture when you compare group delay measurements.

Measuring Electrical Length and Phase Distortion

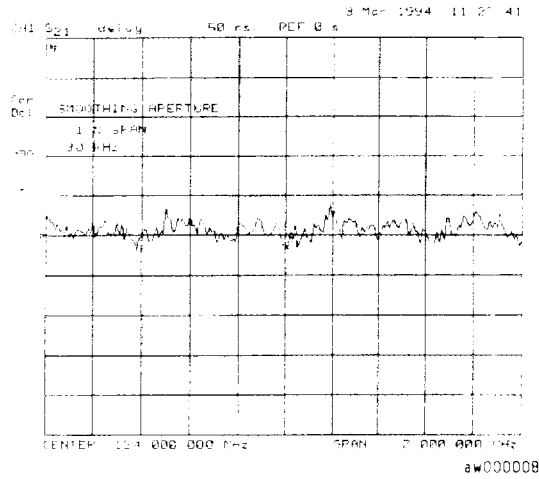

Figure 4-14. Group Delay Example Measurement with Smoothing

- 5 To increase the effective group delay aperture, by increasing the number of measurement points over which the HP 8702D calculates the group delay, press *SMOOTHING APERTURE*, 5, x1.

As the aperture is increased the “smoothness” of the trace improves markedly, but at the expense of measurement detail.

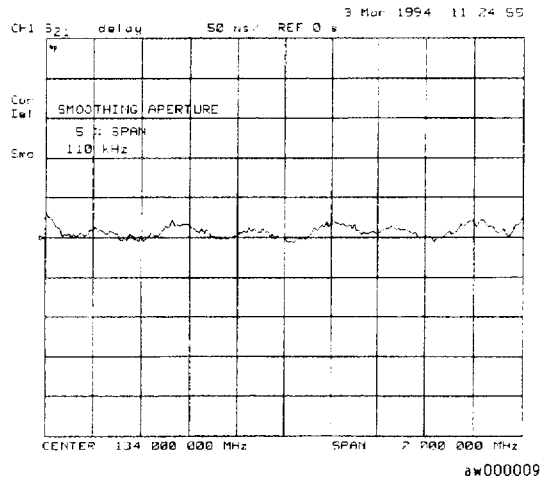

Figure 4-15. Group Delay Example Measurement with Smoothing Aperture Increased

Performing Time Domain Measurements

In addition to transmission and reflection measurements, HP 8702D instruments can display the time domain response by computing the inverse Fourier transform of the frequency domain response. This results in the response of a test device as a function of time and distance. To learn more about time domain measurements, refer to the *HP 8702D Lightweight Component Analyzer Reference* manual.

The three responses shown in Figure 4-16 show the response through a filter. The figure shows RF leakage near zero seconds, the main travel path through the filter, and the triple travel path through the filter.

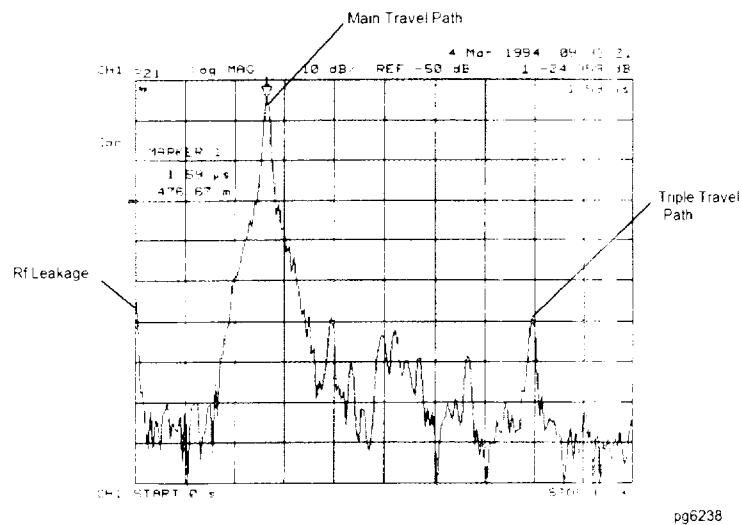

Figure 4-16. Time Domain Transmission Example Measurement

Figure 4-17 shows the effect of removing the RF leakage and the triple travel signal path using gating. By transforming back to the frequency domain, we see that this design change would yield better out-of-band rejection.

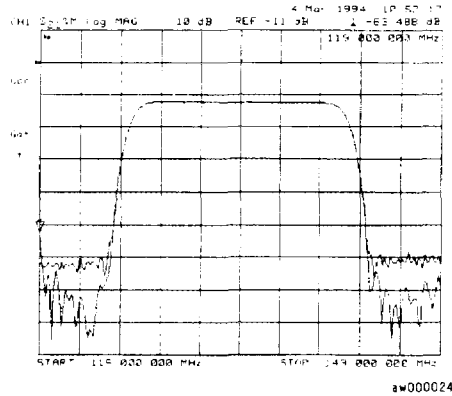

Figure 4-17. Gating Effects in a Frequency Domain Example Measurement

Time domain analysis allows you to mathematically remove individual parts of the time domain response to see the effect of potential design changes. This is accomplished by “gating” out the undesirable responses. With the “gating” capability, the time domain allows you perform “what if” analysis by mathematically removing selected reflections and seeing the effect in the frequency domain.

To measure transmission response

- 1 Connect the device as shown in Figure 4-18.

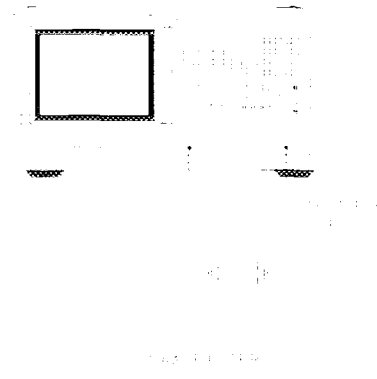

Figure 4-18. Device Connections for Time Domain Transmission

- 2 Set the measurement parameters. For example, press
PRESET
MEAS, *Trans: E/E S21 FWD*
START, 119, M/ μ
STOP, 149, M/ μ
SCALE REF, *AUTO SCALE*
- 3 Substitute a thru for the device under test and perform a frequency response correction. Refer to "Frequency response transmission calibration for E/E measurement" on page 13-25 for a detailed procedure.
- 4 Reconnect your device under test.
- 5 Press SYSTEM, *TRANSFORM MENU*, BANDPASS, *TRANSFORM ON*, START, 0, x1, STOP, 6, M/ μ .
- 6 Press SCALE REF, *REFERENCE VALUE* and turn the front panel knob to optimize the displayed response.
- 7 To measure the peak response from the main path, press:
MARKER FCTN, *MKR SEARCH*, *SEARCH: MAX*

- 8 To access the gate function menu, press:
SYSTEM, TRANSFORM MENU, MORE, SPECIFY GATE, CENTER.
- 9 To set the gate parameters, by entering the marker value, press:
1.6, M/ μ , or turn the front panel knob to position the "T" center gate marker.
- 10 To set the gate span, press:
SPAN, 1.2, M/ μ or turn the front panel knob to position the "flag" gate markers.
- 11 To activate the gating function to remove any unwanted responses, press:
GATE ON.

As shown in Figure 4-19, only response from the main path is displayed.

You may remove the displayed response from inside the gate markers, by pressing SPAN and turning the front panel knob to exchange the "flag" marker positions.

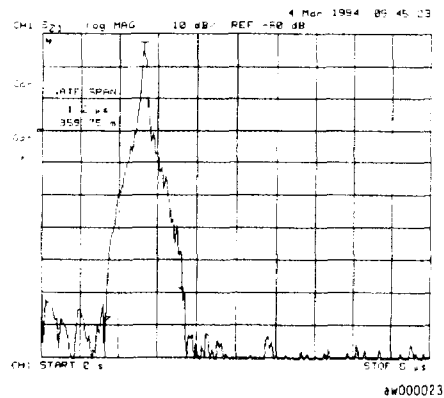

Figure 4-19. Gating in a Time Domain Transmission Example Measurement

- 12 To adjust the gate shape for the best possible time domain response, press *GATE SHAPE* and select between minimum, normal, wide, and maximum. Each gate has a different passband flatness, cutoff rate, and sidelobe levels. (Refer to Table 4-1 on page 4-26.)

Table 4-1. Gate Characteristics

Gate Shape	Passband Ripple	Sidelobe Levels	Cutoff Time	Minimum Gate Span
Gate Span Minimum	±0.1 dB	-48 dB	1.4/Freq Span	2.8/Freq Span
Normal	±0.1 dB	-68 dB	2.8/Freq Span	5.6/Freq Span
Wide	±0.1 dB	-57 dB	4.4/Freq Span	8.8/Freq Span
Maximum	±0.01 dB	-70 dB	12.7/Freq Span	25.4/Freq Span

NOTE: With 1601 frequency points, gating is available only in the passband mode.

The passband ripple and sidelobe levels are descriptive of the gate shape. The cutoff time is the time between the stop time (-6 dB on the filter skirt) and the peak of the first sidelobe, and is equal on the left and right-side skirts of the filter. Because the minimum gate span has no passband, it is just twice the cutoff time.

- 13** To see the effect of the gating in the frequency domain, press:

SYSTEM, TRANSFORM MENU, TRANSFORM OFF
 SCALE REF, AUTO SCALE
 DISPLAY, DATA→MEMORY, MORE, DATA and MEMORY
 SYSTEM, TRANSFORM MENU, MORE, SPECIFY GATE, GATE OFF

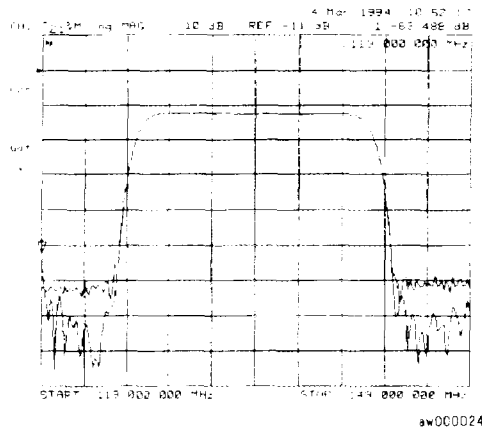

Figure 4-20. Gating Effects in a Frequency Domain Example Measurement

To measure reflection response

- 1 To choose the measurement parameters, press:
PRESET, MEAS, *Ref*: *E S11 FWD*, START, 300, k/m, STOP, 3, G/n
- 2 Perform an S_{11} 1-port correction on Port 1.
- 3 Connect your device under test as shown in Figure 4-21.

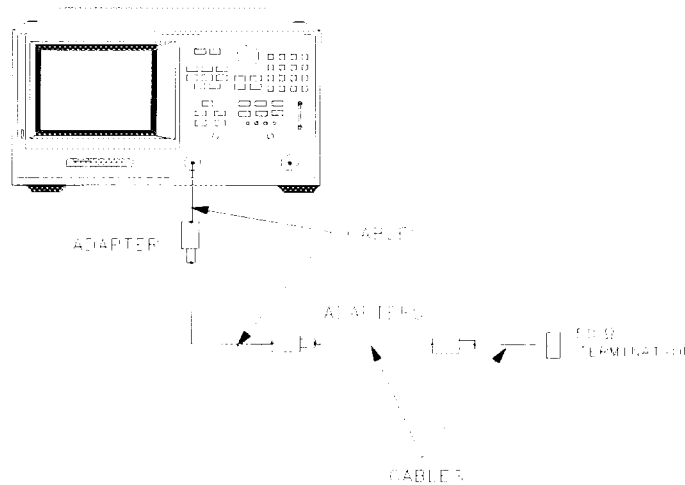

Figure 4-21

Figure 4-21. Device Connections for Reflection Time Domain Measurement

- 4 To better view the measurement trace, press:
SCALE REF, *AUTO SCALE*

Figure 4-22 shows the frequency domain reflection response of the cables under test. The complex ripple pattern is caused by reflections from the adapters interacting with each other. By transforming this data to the time domain, you can determine the magnitude of the reflections versus distance along the cable.

Performing Time Domain Measurements

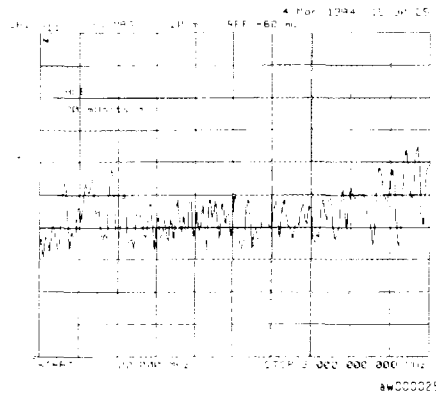

Figure 4-22. Device Response in the Frequency Domain

5 To transform the data from the frequency domain to the time domain, press:
 SYSTEM, TRANSFORM MENU, BANDPASS, TRANSFORM ON

6 To view the time domain over the length (<4 meters) of the cable under test, press:

FORMAT, LIN MAG, START, 0, x1, STOP, 35, G/n

The stop time corresponds to the length of the cable under test. The energy travels about 1 foot per nanosecond, or 0.3 meter/ns, in free space. Most cables have a relative velocity of about 0.66 the speed in free space. Calculate about 3 ns/foot, or 10 ns/meter, for the stop time when you are measuring the return trip distance to the cable end.

7 Press CAL, MORE, VELOCITY FACTOR and enter a velocity factor for your cable under test.

Most cables have a relative velocity of 0.66 (for polyethylene dielectrics) or 0.7 (for Teflon dielectrics).

8 To position the marker on the reflection of interest, press MARKER and turn the front panel knob.

- 9 To position a marker at each reflection of interest, as shown in Figure 4-23, press:

MARKER 2, MARKER 3, MARKER 4, MARKER 5, turning the front panel knob after each key press.

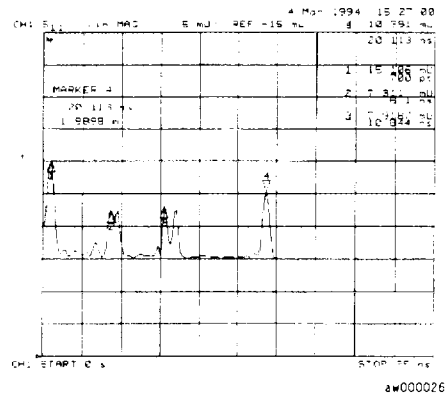

Figure 4-23. Device Response in the Time Domain

Reducing Receiver Crosstalk

Receiver crosstalk can be reduced by performing a response and isolation measurement calibration and setting the sweep to the alternate mode. Alternate sweep is intended for measuring wide dynamic range devices, such as high pass and bandpass filters. This sweep mode removes a type of leakage term through the device under test, from one channel to another.

To reduce crosstalk

- Press *CAL*, *MORE*, *ALTERNATE A AND B*.

Amplifier Testing

Amplifier parameters

The HP 8702D allows you to measure the transmission and reflection characteristics of many amplifiers and active devices. You can measure scalar parameters such as gain, gain flatness, gain compression, reverse isolation, return loss (SWR), and gain drift versus time. Additionally, you can measure vector parameters such as deviation from linear phase, group delay, complex impedance and AM-to-PM conversion.

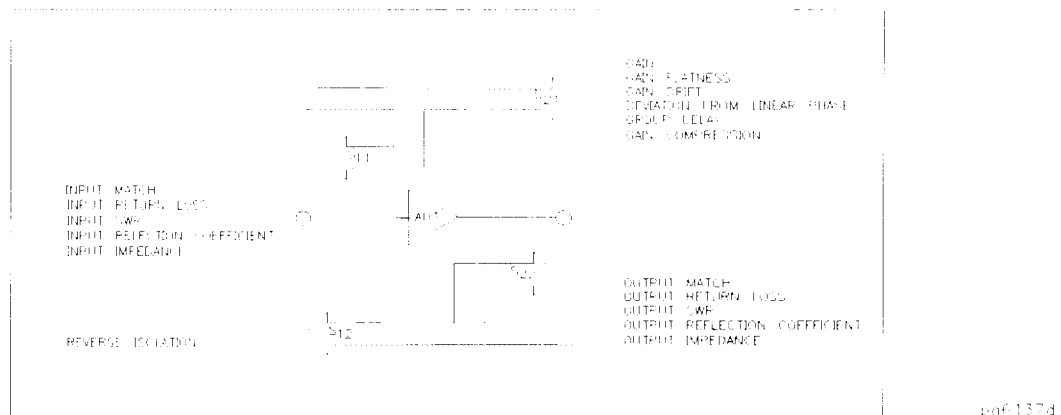

Figure 4-24. Amplifier Parameters

The analyzer allows you to make a swept-frequency measurement of an amplifier's second or third harmonic as shown in Figure 4-25.

Amplifier Testing

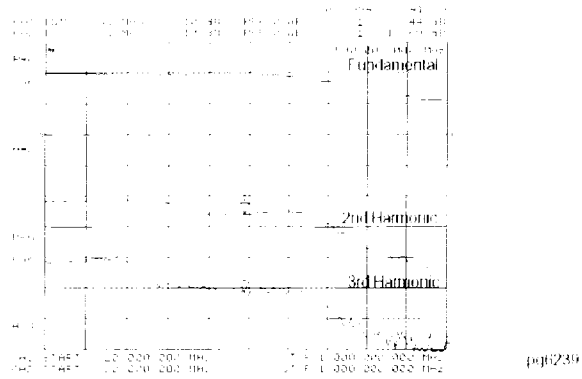

Figure 4-25. Swept Frequency Amplifier Measurement of Absolute Fundamental, 2nd and 3rd Harmonic Output Levels

The second/third harmonic response can be displayed directly in dBc, or dB below the fundamental or carrier (refer to Figure 4-26). The ability to display harmonic level versus frequency or RF power allows “real-time” tuning of harmonic distortion. Further, this swept harmonic measurement, as well as all of the traditional linear amplifier measurements, can be made without reconnecting the test device to a different test configuration.

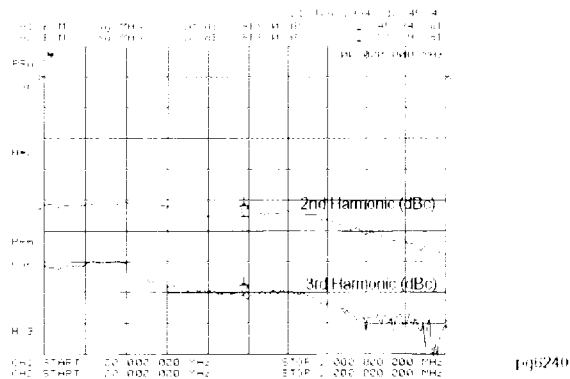
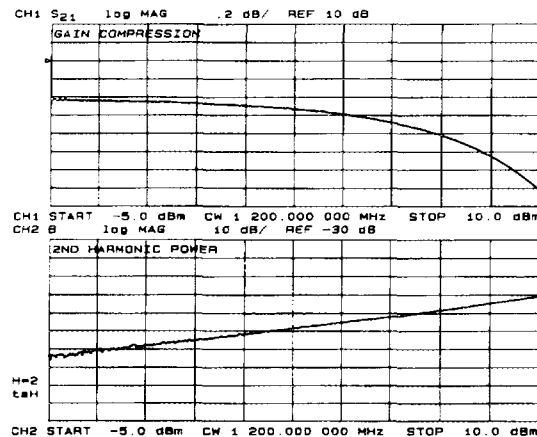

Figure 4-26. Swept Frequency Amplifier Measurement of 2nd and 3rd Harmonic Distortion (dBc)

Vector network analyzers are commonly used to characterize amplifier gain compression versus frequency and power level. This is essentially linear characterization since only the relative level of the fundamental input to the fundamental output is measured. The narrowband receiver is tuned to a precise frequency and, as a result, is immune from harmonic distortion. You may want to quantify the harmonic distortion itself.

Figure 4-27 illustrates a simultaneous measurement of fundamental gain compression and second harmonic power as a function of input power.



pg6164_c

Figure 4-27. Swept Power Measurement of Amplifier's Fundamental Gain Compression and 2nd Harmonic Output Level

In a compression measurement, it is necessary to know the RF input or output power at a certain level of gain compression. Therefore, both gain and absolute power level need to be accurately characterized. Uncertainty in a gain compression measurement is typically less than 0.05 dB. Also, each input channel of the analyzer is calibrated to display absolute power (typically within +0.5 dBm up to 3 GHz, and +1 dB up to 6 GHz).

Metering the power level

When you are measuring a device that is very sensitive to absolute power level, it is important that you accurately set the power level at either the device input or output. The analyzer is capable of using an external HP-IB power meter and controlling source power directly. Figure 4-28 shows a typical test configuration for setting a precise leveled input power at the device input. Refer to "Calibrating with a Power Meter" on page 13-55 for more information.

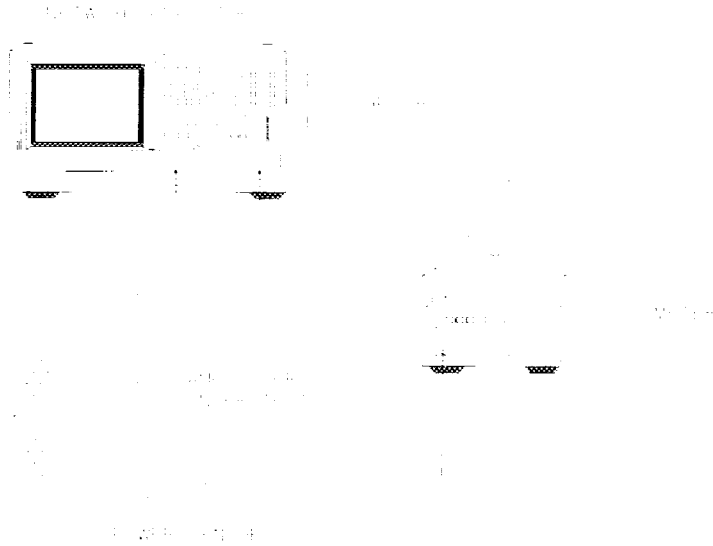

Figure 4-28. Test Configuration for Setting RF Input using Automatic Power Meter Calibration

Performing Swept Power Measurements

The *POWER SWEEP* softkey turns on a power sweep mode that is used to characterize power-sensitive circuits. In this mode, power is swept at a single frequency, from a start power value to a stop power value, selected using the *START* and *STOP* keys and the front-panel keys. This feature is convenient for such measurements as gain compression or AGC (automatic gain control) slope. To set the frequency of the power sweep, use *CWFREQ* in the stimulus menu.

The span of the swept power is limited to being equal to or within one of the eight predefined power ranges. The attenuator will *not* switch to a different power range while in the power sweep mode. Therefore, when performing a power sweep, power range selection will automatically switch to the manual mode.

In power sweep, the entered sweep time may be automatically changed if it is less than the minimum required for the current configuration (number of points, IF bandwidth, averaging, etc.)

Measuring Gain Compression

Gain compression occurs when the input power of an amplifier is increased to a level that reduces the gain by 1 dB. The gain compression will vary with frequency, so it is necessary to find the worst case point in the frequency band. Once that point is identified, you can perform a power sweep of that CW frequency to measure the input power at which the 1 dB compression occurs and the absolute power out (in dBm) at compression. The following steps provide detailed instructions on how to apply various features of the HP 8702D to accomplish these measurements.

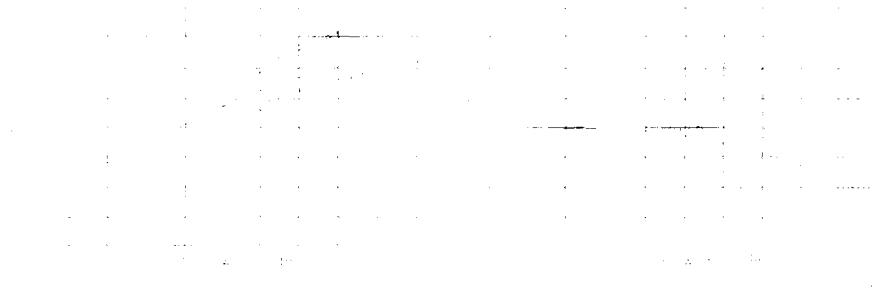

Figure 4-29. Diagram of Gain Compression

- 1** Set up your stimulus and response parameters, error-correct the instrument, and connect the amplifier.
- 2** To view both channels simultaneously, press:
DISPLAY, DUAL CHANNEL ON
- 3** To reduce the effect of noise on the trace, press:
AVG, IF BW, 1000, x1

- To uncouple the channel stimulus, so that the channel power will be uncoupled, press:

MENU, *COUPLED CH OFF*

This will allow you to separately increase the power for channel 2 and channel 1, so that you can observe the gain compression on channel 2 while channel 1 remains unchanged.

- To display the ratio of channel 2 data to channel 1 data on the channel 2 display, press:

CHAN 2, DISPLAY, *MORE D2/D1 to D2 ON*

This produces a trace that represents gain compression only.

- Press MARKER, *MARKER 1* and position the marker at approximately mid-span.

- Press SCALE REF, *SCALE/DIV, 1, x1* to change the scale to 1 dB per division.

- Press MENU, *POWER*.

- Increase the power until you observe approximately 1 dB of compression on channel 2, using the step keys or the front panel knob.

- To locate the worst case point on the trace, press:

MARKER FCTN, *MKR SEARCH, SEARCH:MIN*

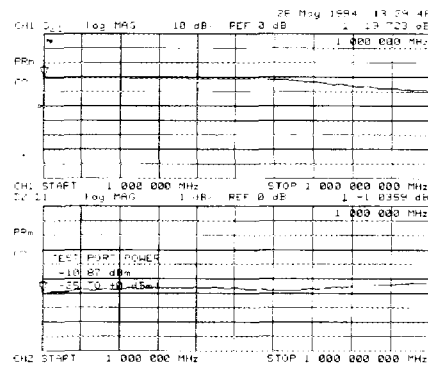

Figure 4-30. Gain Compression Using Linear Sweep

- To recouple the channel stimulus, press:

MENU, *COUPLED CH ON*

- 12** To place the marker *exactly* on a measurement point, press:
MARKER FCTN, *MARKER MODE MENU*, *MARKERS:DISCRETE*
- 13** To set the CW frequency before going into the power sweep mode, press:
SEQ, *SPECIAL FUNCTIONS*, *MARKER → CW*
- 14** To maintain the calibration for the CW frequency, press:
CAL, *INTERPOL ON*
- 15** Press MENU, *SWEEP TYPE MENU*, *POWER SWEEP* and enter the start and stop power levels for the sweep.

Channel 1 is displaying a gain compression curve. (Do not pay attention to channel 2 at this time.)
- 16** Press CHAN 2, DISPLAY, *MORE*, *D2/D1 to D2 OFF*.
- 17** Press MEAS, *INPUT PORTS*, *B*.

Channel 2 displays absolute output power (in dBm) as a function of power input.

A receiver calibration will improve the accuracy of this measurement. Refer to Chapter 5, "Optimizing Your Measurement Results."
- 18** Press CHAN 1, MARKER FCTN, *MARKER MODE MENU*, *MARKERS:COUPLED*.

19 To find the 1 dB compression point on channel 1, press:

MARKER FCTN, *MKR SEARCH*, *SEARCH:MAX*
MARKER, *MKR ZERO*
MARKER FCTN, *MKR SEARCH*, *SEARCH:TARGET*, -1, x1

Notice that the marker on channel 2 tracked the marker on channel 1.

20 Press CHAN 2, MARKER FCTN, *MARKER MODE MENU*, *MARKERS:UNCOUPLED*.

21 To take the channel 2 marker out of the Δ mode so that it reads the absolute output power of the amplifier (in dBm), press:

MARKER, Δ *MODE MENU*, Δ *MODE OFF*

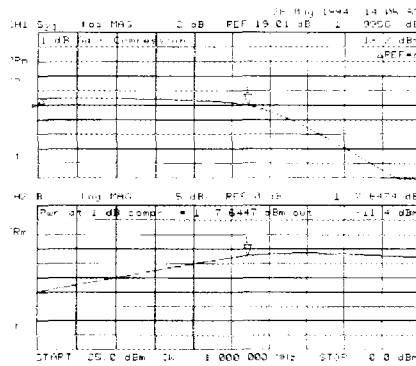

Figure 4-31. Gain Compression Using Power Sweep

Measuring Gain and Reverse Isolation Simultaneously

This section provides a procedure to show you how to simultaneously measure gain (S_{21}) and reverse isolation (S_{12}). The procedure uses the dual channel display mode.

Since an amplifier will have high gain in the forward direction and high isolation in the reverse direction, the gain (S_{21}) will be much greater than the reverse isolation (S_{12}). Therefore, the power you apply to the input of the amplifier for the forward measurement (S_{21}) should be considerably lower than the power you apply to the output for the reverse measurement (S_{12}).

By applying low power in the forward direction, you'll prevent the amplifier from being saturated. A higher power in the reverse direction keeps noise from being a factor in the measurement and accounts for any losses caused by attenuators or couplers on the amplifier's output needed to lower the output power into the HP 8702D.

If the port power levels are in different power ranges, one of the displayed measurements will not be kept updated and the annotation tSH will appear on the left side of the display. To obtain best accuracy, you should set the power levels prior to performing the calibration. However, the HP 8702D compensates for nominal power changes you make during a measurement, so that the error correction still remains approximately valid. In these cases, the Cor annunciator will change to $C?$.

To measure gain and reverse isolation

- 1 Press MENU, *COUPLED CH ON*.

Coupling the channels allows you to have the same frequency range and calibration applied to channel 1 and channel 2.

- 2 Press POWER, *PORT POWER [UNCOUPLED]*.

Uncoupling the port power allows you to apply different power levels at each port. In Figure 4-32, the port 1 power is set to -25 dBm for the gain measurement (S_{21}) and the port 2 power is set to 0 dBm for the reverse isolation measurement (S_{12}).

- 3 Press CHAN 1, MEAS, *Trans: E/E S21 FWD*, MENU, POWER and set the power level for port 1.

- 4 Press CHAN 2, MEAS, *Trans: E/E S12 REV*, MENU, POWER and set the power level for port 2.

- 5 Perform an error-correction and connect the amplifier to the HP 8702D.

- 6 Press DISPLAY, *DUAL CHAN ON*.

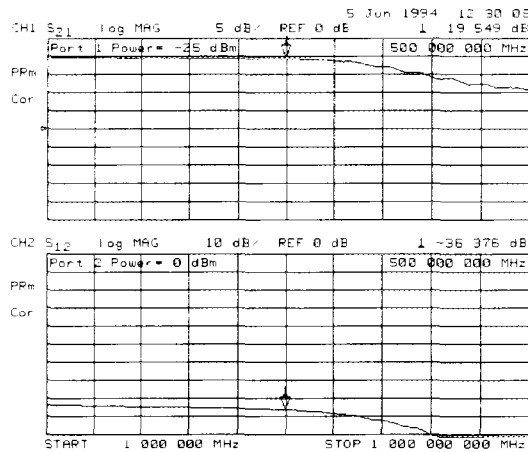

Figure 4-32. Gain and Reverse Isolation

Performing Harmonic Measurements (Option 002)

The HP 8702D Option 002 has the unique capability of measuring the second and third harmonic as the analyzer's source sweeps fundamental frequencies above 16 MHz. The analyzer can make harmonic measurements in any sweep type.

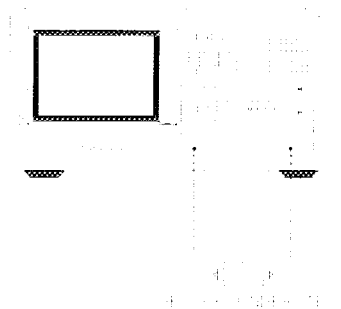

Figure 4-33. Typical Harmonic Mode Test Setup

Single-channel operation

You can view the second and third harmonic alone by using only one of the analyzer's two channels.

Dual-channel operation

To make the following types of measurements, uncouple channel 1 and 2, and switch on dual channel.

- The analyzer measures the fundamental on one channel while measuring the second or third harmonic on the other channel.
- The analyzer measures the second harmonic on one channel while measuring the third harmonic on the other channel.

- Using the *COUPLE PWR ON OFF* feature, the analyzer measures the fundamental on channel 1 while measuring the second or third harmonic on dBc on channel 2.
- Using the *COUPLE PWR ON OFF* feature, the analyzer couples power between channels 1 and 2. This is useful when you are using the *D2/D1 to D2* feature, because you can change fundamental power and see the resultant change in the harmonic power.

The analyzer shows the fundamental frequency value on the display. However, a marker in the active entry area shows the harmonic frequency, in addition to the fundamental. If you use the harmonic mode, the annotation H=2 or H=3 appears on the left-hand side of the display. The measured harmonic *cannot* exceed the frequency limitations of the analyzers receiver.

Coupling power between channels 1 and 2

COUPLER PWR ON OFF is intended to be used with the *D2/D1 to D2 ON OFF* softkey. You can use the *D2/D1 to D2* function in harmonic measurements, where the analyzer shows the fundamental on channel 1 and the harmonic on channel 2. *D2/D1 to D2* ratios the two, showing the fundamental and the relative power of the measured harmonic in dBc. You must uncouple channels 1 and 2 for this measurement, using the *COUPLED CHAN ON OFF* softkey set to *OFF* to allow alternating sweeps.

After uncoupling channels 1 and 2, you may want to change the fundamental power and see the resultant change in relative harmonic power (in dBc). *COUPLER PWR ON OFF* allows you to change the power of both channels simultaneously, even though they are uncoupled in all other respects.

Frequency range

The frequency range is determined by the upper frequency range of the instrument or system (3 or 6 GHz) and by the harmonic being displayed. The 6 GHz operation requires an HP 8702D Option 006. Table 4-2 shows the highest fundamental frequency for maximum frequency and harmonic mode.

Table 4-2. Maximum Fundamental Frequency using Harmonic Mode

Harmonic Measured	Maximum Fundamental Frequency	
	HP 8702D	HP 8702D Option 006
2nd Harmonic	1.5 GHz	3 GHz
3rd Harmonic	1.0 GHz	2.0 GHz

Accuracy and input power

Refer to the *HP 8702D Reference* manual for information on specifications and measurement uncertainties. The maximum recommended input power and maximum recommended source power are related specifications.

Using power levels greater than the recommended values may cause undesired harmonics in the source and receiver. The recommended power levels ensure that these harmonics are less than 45 dBc. Use test port power to limit the input power to your test device.

- 1** Press CHAN 1, MEAS, *INPUT PORTS*, *B* to measure the power for the fundamental frequencies.
- 2** Press CHAN 2, MEAS, *INPUT PORTS*, *B* to measure the power for the harmonic frequencies.
- 3** Set the start frequency to a value greater than 16 MHz.
- 4** Press MENU, *COUPLED CHAN OFF*. Uncoupling the channels allows you to have the separate sweeps necessary for measuring the fundamental and harmonic frequencies.
- 5** Press *POWER*, *CHAN POWER [COUPLED]*. Coupling the channel power allows you to maintain the same fundamental frequency power level for both channels.
- 6** Press MENU, *POWER* and set the power level for both channels.
- 7** Press DISPLAY, *DUAL CHAN ON*.
- 8** Press MARKER and position the marker to a desired frequency.

- 9 Press SYSTEM, HARMONIC MEAS, SECOND. You can view both the fundamental power and harmonic power levels at the same time. Refer to Figure 4-34.

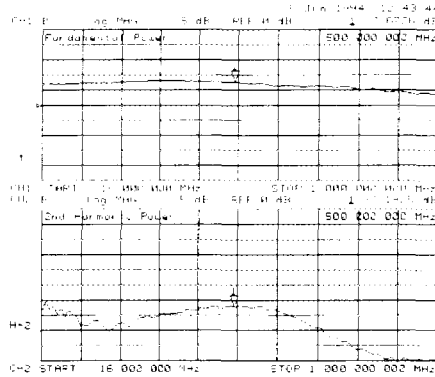

Figure 4-34. Fundamental and 2nd Harmonic Power Levels in dBm

- 10 Press CHAN 2, DISPLAY, MORE, D2/D1 to D2 ON. The display mode lets you see the relationship between the fundamental and second or third harmonic in dBc. Refer to Figure 4-35.

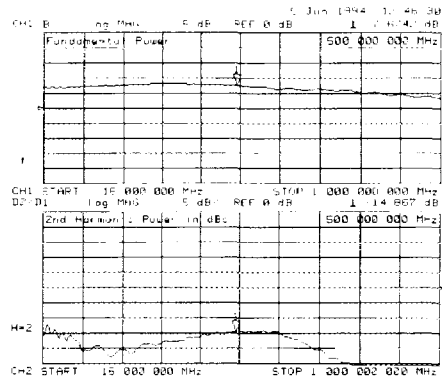

Figure 4-35. 2nd Harmonic Power Level in dBc

Mixer Testing

Mixers or frequency converters, by definition, exhibit the characteristic of having different input and output frequencies. For a single-sideband mixer measurement, the RF source can be offset in frequency from the input receiver frequency, allowing for a swept RF stimulus over one frequency range and measurement of the IF response over another (in this case, the output IF).

Mixer parameters that you can measure

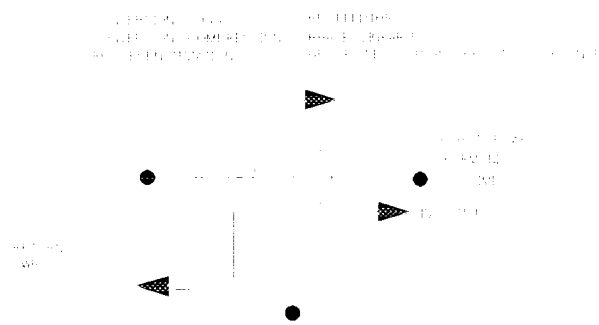

Figure 4-36. Mixer Parameters

- Transmission characteristics include conversion loss, conversion compression, RF desensitization, group delay, and RF feedthru.
- Reflection characteristics include return loss, SWR and complex impedance.
- Characteristics of the signal at the output port include the output power, the spurious or harmonic content of the signal, and intermodulation distortion.
- Other parameters of concern are isolation terms, including LO to RF isolation and LO to IF isolation.

Accuracy considerations

In mixer transmission measurements, you have RF and LO inputs and an IF output. Also emanating from the IF port are several other mixing products of the RF and LO signals. In mixer reflection measurements, leakage signals from one mixer port propagate and appear at the other two mixer ports. These unwanted mixing products or leakage signals can cause distortion by mixing with a harmonic of the analyzer's first down-conversion stage. To ensure that measurement accuracy is not degraded, you must filter certain frequencies or avoid them by frequency selection. If you place attenuators at all mixer ports, you can reduce mismatch uncertainties.

Filtering

Harmonics, linearity, and spurious signals also introduce errors that are not removed by frequency response calibration. These errors are smaller with a narrowband detection scheme, but they may still interfere with your measurements. You should filter the IF signal to reduce these errors as much as possible.

Correct filtering between the mixer's IF port and the receiver's input port can eliminate unwanted mixing and leakage signals from entering the analyzer's receiver. Figure 4-37 shows a plot of mixer conversion loss when proper IF filtering was neglected.

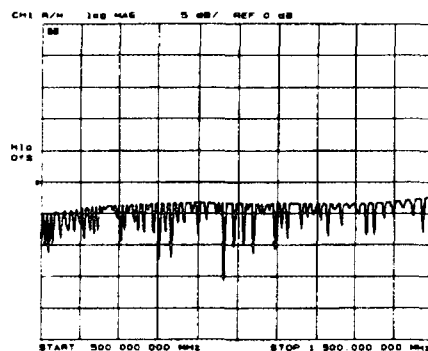

pg6160_c

Figure 4-37. Example of Conversion Loss versus Output Frequency Without Correct IF Signal Path Filtering

Mixer Testing

Figure 4-38 shows the same mixer's conversion loss with the addition of a low pass filter at the mixer's IF port.

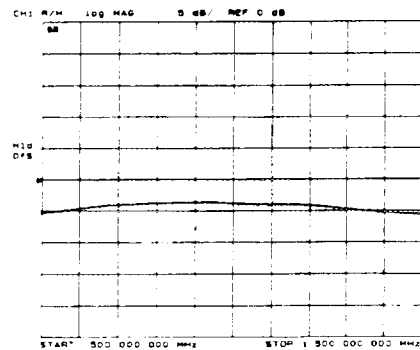

pg616 1 c

Figure 4-38. Example of Conversion Loss versus Output Frequency With Correct IF Signal Path Filtering and Attenuation at all Mixer Ports

Filtering is required in both fixed and broadband measurements, but you can implement it more easily in the fixed situation. Therefore, when configuring broad-band (swept) measurements, you may need to trade some measurement bandwidth for the ability to more selectively filter signals entering the analyzer's receiver.

Attenuation at mixer ports

Mismatch between the instruments, cables, and mixer introduces errors in the measurement that you *cannot* remove with a frequency response calibration. You can reduce the mismatch by using high quality attenuators as close to the mixer under test as possible.

When characterizing linear devices, you can use vector accuracy enhancement (measurement calibration) to mathematically remove all systematic errors from the measurement, including source and load mismatches. This is not possible when the device you are characterizing is a mixer operating over multiple frequency ranges. Therefore, source and load mismatches are not corrected for and will add to overall measurement uncertainty.

To reduce the measurement errors associated with the interaction between mixer port matches and system port matches, you can place attenuators at all of the mixer's ports. Figure 4-39 shows a plot of swept conversion loss where no attenuation at mixer ports was used. The ripple versus frequency is due to source and load mismatches.

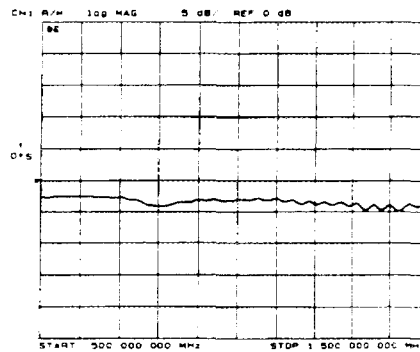

pg6162_c

Figure 4-39. Conversion Loss versus Output Frequency Without Attenuators at Mixer Ports

In contrast, Figure 4-38 made use of appropriate attenuation at all mixer ports. You should give extra care to the selection of the attenuator located at the mixer's IF port to avoid overdriving the receiver. For best results, choose the value of this attenuator so that the power incident on the analyzer's R channel port is less than -10 dBm.

Frequency selection

When choosing test frequencies (frequency list mode), you can reduce the effect of spurious responses on measurements by avoiding frequencies that produce IF signal path distortion.

The first step in avoiding or eliminating spurs is determining at what frequencies they will occur. To aid you in predicting where these frequencies will occur, a spur prediction program is included later in this section. Although this spur prediction program is specialized for the measurement of the swept IF/ fixed LO response of a mixer, you can modify it to accommodate other measurement configurations.

LO frequency accuracy and stability

The analyzer source is phase-locked to its receiver through a reference loop. In the frequency offset mode, the mixer under test is inserted in this loop. To ensure that the analyzer phase-locks correctly, it is important that you use an LO source that has frequency accuracy better than ± 1 MHz and residual FM < 20 kHz RMS.

Up-conversion and down-conversion definition

When you choose between $RF < LO$ and $RF > LO$ in the frequency offset menus, the analyzer determines which direction the internal source must sweep in order to achieve the requested IF frequency. For example, to measure the lower sideband of a mixer, where the RF signal is below the LO ($RF < LO$), the internal source must sweep backwards. See the examples in Figure 4-40.

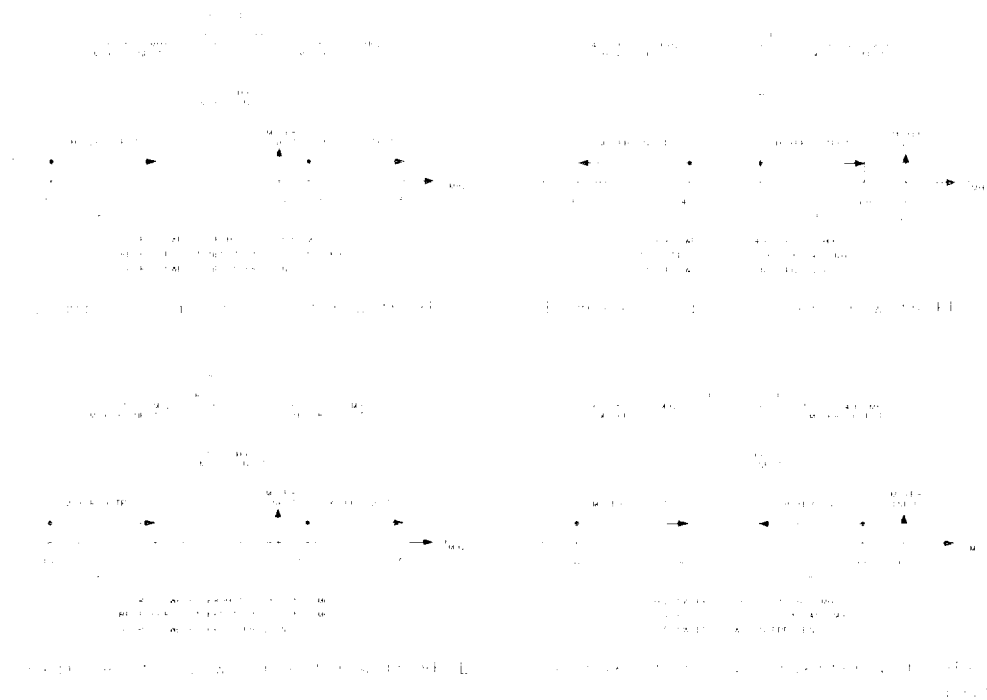

Figure 4-40. Examples of Up Converters and Down Converters

Notice that for down-converter measurements the device RF port is an input, and for up-converter measurements, the device RF port is an output. This refers to the mixer ports only. Figure 4-40 also shows how the RF/IF labeling of the device varies on the analyzer graphic display.

Conversion loss

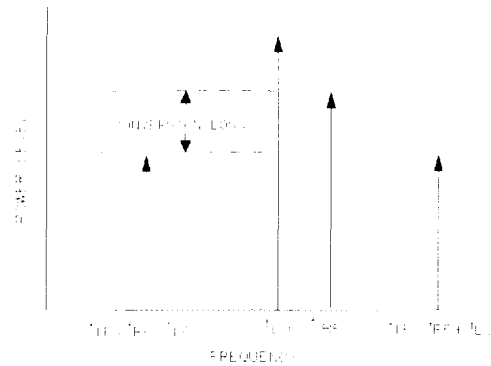

FIGURE 4-41

Figure 4-41. Example Spectrum of RF, LO, and IF Signals Present in a Conversion Loss Measurement

Conversion loss is a measure of how efficiently a mixer converts energy from one frequency to another. It is the ratio of the sideband output power to input signal power and is usually expressed in dB.

Since the frequency response of the test system gets measured with the mixer's response, you can perform a frequency response calibration to remove this group of errors.

Isolation

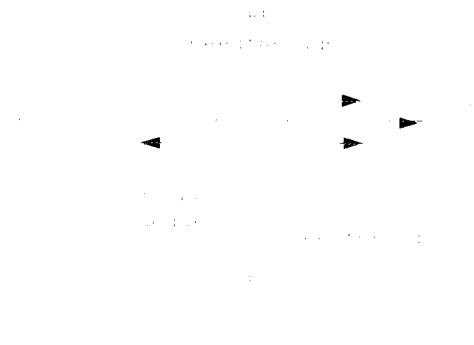

Figure 4-42. Main Isolation Terms

Isolation is the amount of attenuation provided when a signal is applied to one port of a mixer and measured at another port. Figure 4-42 shows the three main isolation terms.

LO feedthru

LO feedthru, or LO-to-IF isolation, is the amount the LO signal is attenuated when it reaches the IF port.

LO to RF isolation is the amount the LO power is attenuated when it appears directly at the RF port.

Both of these LO isolation terms are small for single and double balanced mixers. The RF signal level applied to the mixer will have an effect on this measurement. For this reason, these terms are usually measured with the RF port of the mixer terminated in a matched state.

RF feedthru

RF feedthru, or RF-to-IF isolation, is the amount the RF power is attenuated when it reaches the IF port. This value is low in double-balanced mixers. RF feedthru is usually less of a problem than the LO isolation terms because the LO power level is significantly higher than the RF power drive.

You can make an RF feedthru measurement using the same instruments and setup that you use to measure conversion loss. Because the source and receiver frequencies are the same, the analyzer can use narrowband (tuned receiver) detection to make the measurement. The only difference that you need in the hardware configuration is that the IF filter needs to be removed so the RF feedthru will not be filtered out.

The RF signal is applied to the RF port of the mixer and the feedthru is measured at the IF port.

The RF feedthru level is very dependent on the LO signal that is applied. For this reason, you should make the measurement with the LO signal present at its normal operating level.

You should perform a frequency response calibration to improve accuracy.

SWR / return loss

Reflection coefficient (Γ) is defined as the ratio between the reflected voltage (V_r) and incident voltage (V_i). Standing wave ratio (SWR) is defined as the ratio of maximum standing wave voltage to the minimum standing wave voltage and can be derived from the reflection coefficient (Γ) using the equation shown below.

$$\Gamma = V_r/V_i$$

$$SWR = 1 + |\Gamma| / 1 - |\Gamma|$$

$$\text{Return loss} = -20 \log |\Gamma|$$

NOTE

Mixers are three-port devices, and the reflection from any one port depends on the conditions of the other two ports. You should replicate the operating conditions the mixer will experience as closely as possible for the measurement.

When you measure the RF port SWR, you should have the LO drive level present and set to the expected frequency and power levels. The IF port should be terminated in a condition as close to its operating state as possible.

The measurements of LO port SWR and IF port SWR are very similar. For IF port SWR, you should terminate the RF port in a matched condition and apply the LO signal at its normal operating level. For the LO port SWR, the RF and IF ports should both be terminated in conditions similar to what will be present during normal operation.

Frequency offset

The analyzer's frequency offset mode allows the analyzer to offset its source and receiver by a specified frequency.

To use the frequency offset guided setup for configuring a mixer measurement:

- 1 Enter the IF and LO frequencies.
- 2 Specify up conversion or down conversion.
- 3 Select an RF that is higher or lower in frequency than the LO. (The RF frequencies needed are calculated by the analyzer.)

Tuned receiver

The HP 8702D's tuned receiver mode allows you to tune its receiver to an arbitrary frequency and measure signal power. This is only possible if the signal you want to analyze is at an exact known frequency. Therefore, the RF and LO sources must be synthesized and synchronized with the analyzer time base. Since the analyzer is not phase-locking in this configuration, you can use it to measure conversion loss of a microwave mixer with an RF frequency range output.

NOTE

You must take care to filter the output of the mixer because some of the intermodulation and leakage products may be very close in frequency to the desired IF. If these components are not filtered off, the analyzer may have difficulty selecting the correct signal to measure.

Tuned receiver mode also increases dynamic range. Broadband techniques like diode detection have a high noise floor, while narrowband techniques like tuned receivers are much less susceptible to noise.

Conversion compression

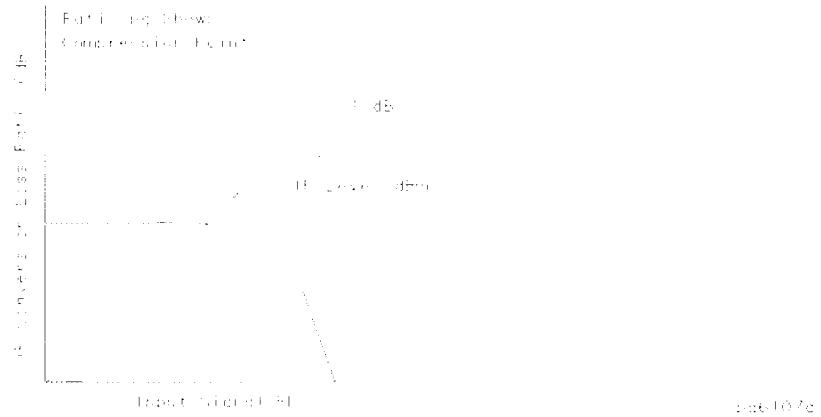

Figure 4-43. Conversion Loss and Output Power as a Function of Input Power Level

Conversion compression is a measure of the maximum RF input signal level for which the mixer will provide linear operation. The conversion loss is the ratio of the IF output level to the RF input level, and this value remains constant over a specified input power range. When the input power level exceeds a certain maximum, the constant ratio between IF and RF power levels will begin to change. The point at which the ratio has decreased 1 dB is called the 1 dB compression point.

Notice in Figure 4-43 that the output power increases linearly with the increasing input signal level, until mixer compression begins and the mixer saturates.

You can measure conversion compression using the same basic test configurations that are used to measure the conversion loss.

To set up for a conversion compression measurement, first measure the conversion loss of the mixer under test. Set up for a CW measurement at the frequency of interest. Sweeping the RF drive level over a 25 dB span soon shows the power level at which the conversion loss increases by 1 dB.

With power meter calibration controlling the RF drive level, and the receiver calibrated to measure output power, you can make accurate measurements of the output power at the 1 dB compression point.

Phase measurements

When you are making linear measurements, provide a reference for determining phase by splitting the RF source power and send part of the signal into the reference channel. (This does not work for frequency offset measurements, since the source and receiver are functioning at different frequencies.)

To provide a reference signal for the phase measurement, you need a second mixer. This mixer is driven by the same RF and LO signals that are used to drive the mixer under test. The IF output from the reference mixer is applied to the reference (R) channel of the analyzer.

Amplitude and phase tracking

The match between mixers is defined as the absolute difference in amplitude and/or phase response over a specified frequency range. The tracking between mixers is essentially how well the devices are matched over a specified interval. This interval may be a frequency interval or a temperature interval, or a combination of both.

You can make tracking measurements by ratioing the responses of two mixer conversion loss measurements. Then any difference you view in response is due to the mixers and not the measurement system.

Replace mixer A with the mixer that you want to compare it to. Mixer R should always remain in place as the reference mixer.

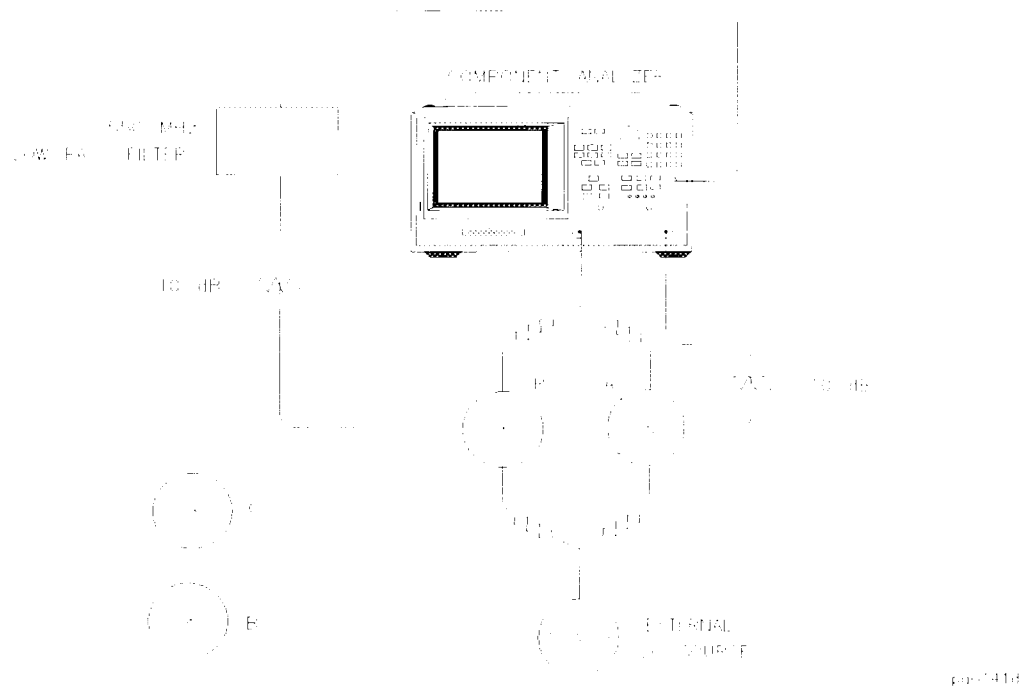

Figure 4-44. Connections for an Amplitude and Phase Tracking Measurement Between Two Mixers

Phase linearity and group delay

Group delay is the rate of change of phase through a device with respect to frequency ($d\phi/d\omega$). Traditionally, group delay has been used to describe the propagation delay (τ_g), and deviation from linear phase through a linear device. However, this parameter also contains valuable information about transmission delay and distortion through a non-linear device such as a mixer or frequency converter. For example, flat group delay corresponds to low modulation distortion (that is, carrier and sidebands propagate at the same rate).

Phase linearity and group delay are both measurements of the distortion of a transmitted signal. Both measure the non-linearity of a device's phase response with respect to frequency.

Mixer Testing

In standard vector error correction, a thru (delay=0) is used as a calibration standard. The solution to this problem is to use a calibration mixer with very small group delay as the calibration standard.

An important characteristic to remember when selecting a calibration mixer is that the delay of the device should be kept as low as possible. To do this, select a mixer with very wide bandwidth (wider bandwidth results in smaller delay).

Spur analysis and prediction for mixer measurements

The analyzer is susceptible to spurious responses caused by unwanted mixing products of the device entering and mixing with the analyzer's sampler-based receiver. The easiest way to eliminate these spurs is to stop the unwanted signals from entering the analyzer. For fixed IF mixer measurements, this is accomplished by using a bandpass filter (BPF) centered around the mixer's IF signal. For swept measurements, filtering alone may not remove all unwanted signals. If this is the case, both filtering and frequency selection (frequency list mode) will be necessary. The following spur prediction program will help you select the frequencies to avoid when you are measuring a mixer's response.

Spur analysis

Figure 4-45 shows a mixer under test having RF and LO inputs and an IF output. Also emanating from the mixer's IF port are several other mixing products of the RF and LO signals. These unwanted mixing products can cause spurious responses in the analyzer's IF signal path that will degrade measurement accuracy. For this reason, you must avoid or reduce spurious responses.

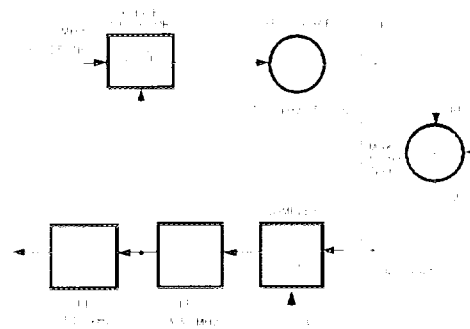
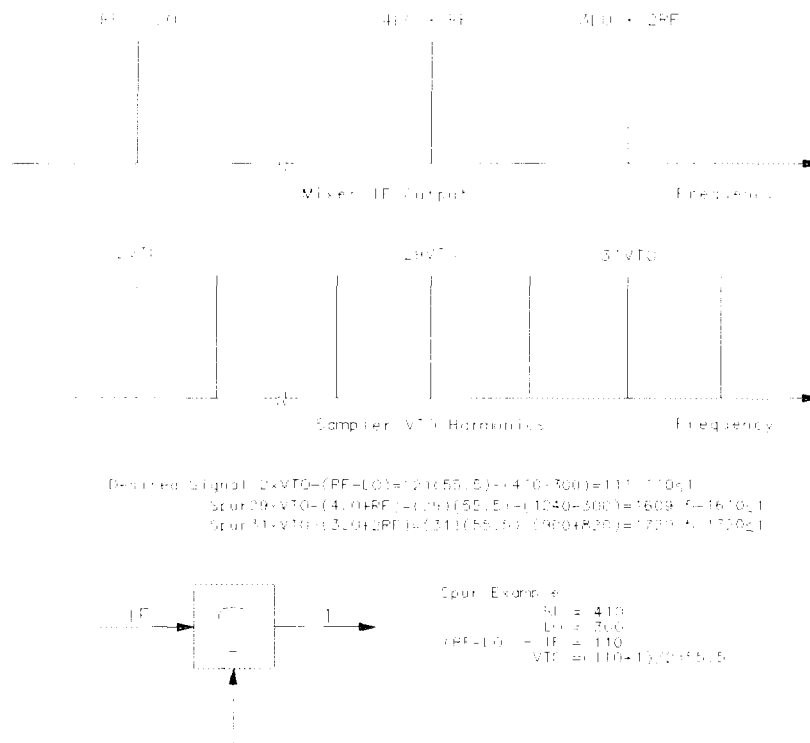

Figure 4-45. Diagram of the Analyzer Receiver and a Mixer Under Test

The method used in the analyzer to down convert incoming IF signals to 1 MHz for internal processing is called sampling. The sampling method presents all of the frequency harmonics of the receiver's voltage-tuned oscillator (VTO) to the incoming IF signal. The VTO is retuned and phase locked so that one of its harmonics mixes with the incoming IF signal to give exactly 1 MHz. An internal 1 MHz BPF stops all other mixing products of the RF, LO and VTO, which are not at 1 MHz, from continuing on inside the analyzer. However, if the incoming IF signal is composed of many different frequency components, it is possible that some other component of the IF signal will combine with a different harmonic of the VTO and also produce a signal at 1 MHz (refer to Figure 4-46). This unwanted signal will then proceed through the internal 1 MHz BPF, along with the desired signal, and cause a spurious measurement response.



eq6147d

Figure 4-46. Diagram of Mixer IF Output and Sampler VTO Harmonics versus Frequency

Performing On-Wafer Measurements

On-wafer measurements presents a unique set of challenges for error correction in the analyzer:

- The close spacing between the microwave probes makes it difficult to maintain a high degree of isolation between the input and the output.
- The type of device measured on-wafer often is not always a simple two-port.
- It may be difficult to make repeatable on-wafer contacts due to the size of the device contact pads.

The HP 8702D provides a new capability to the HP 8702 family of analyzers with TRL* (thru-reflect-line) calibration. The TRL* calibration technique relies only on the characteristic impedance of a short transmission line. From two sets of 2-port measurements that differ by this short length of transmission line and two reflection measurements, the full 12-term error model can be determined. Due to the simplicity of the calibration standards, TRL* calibrations are particularly suited for on-wafer measurements. The TRL* calibration with time domain gating and a variety of probe styles can provide optimal accuracy in on-wafer measurements. Refer to "TRM* (TRL*) calibration for E/E measurement" on page 13-33 for more information.

Connection Considerations

Adapters

To minimize the error introduced when you add an adapter to a measurement system, the adapter needs to have low SWR or mismatch, low loss, and high repeatability.

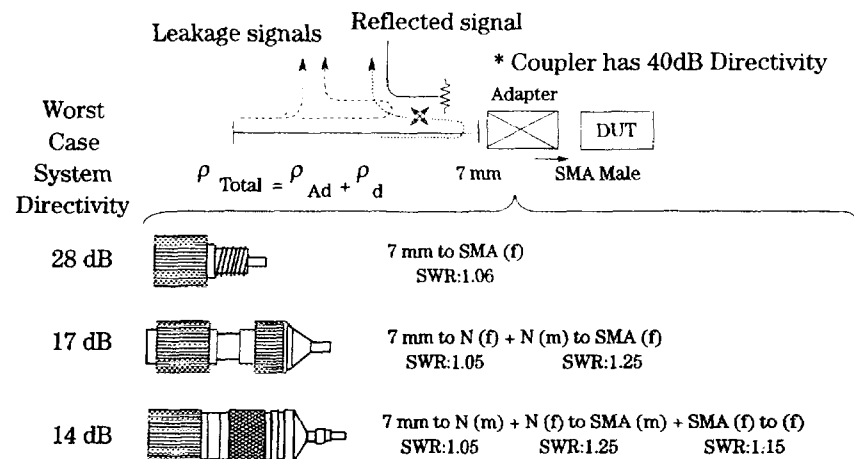

pg6237

Figure 4-47. Adapter Considerations

In a reflection measurement, the directivity of a system is a measure of the error introduced by an imperfect signal separation device. It typically includes any signal that is detected at the coupled port which has not been reflected by the test device. This directivity error will add with the true reflected signal from the device, causing an error in the measured data. Overall directivity is the limit to which a device's return loss or reflection can be measured. Therefore, it is important to have good directivity to measure low reflection devices.

For example, a coupler has a 7 mm connector and 40 dB directivity, which is equivalent to a reflection coefficient of $\rho=0.01$ (directivity in dB = $-20 \log \rho$). Suppose we want to connect to a device with an SMA male connector. We need to adapt from 7 mm to SMA.

If we choose a precision 7 mm to SMA adapter with a SWR of 1.06, which has $\rho=0.03$, the overall directivity becomes $\rho=0.04$ or 28 dB. However, if we use two adapters to do the same job, the reflection from each adapter adds up to degrade the directivity to 17 dB. The last example, shown in Figure 4-47, uses three adapters that shows an even worse directivity of 14 dB. It is clear that a low SWR is desirable to avoid degrading the directivity of the system.

Fixtures

Fixtures are needed to interface non-coaxial devices to coaxial test instruments. It may also be necessary to transform the characteristic impedance from standard 50 or 75 ohm instruments to a non-standard impedance and to apply bias if an active device is being measured.

For accurate measurements, the fixture must introduce minimum change to the test signal, not destroy the test device, and provide a repeatable connection to the device.

Several fixtures for TO cans, stripline, and microstrip devices are available. Refer to the *HP 8702D Reference* manual for further information.

If you want to design your own fixture

Ideally, a fixture should provide a transparent connection between the test instrument and the test device. This means it should have no loss or electrical length and a flat frequency response, to prevent distortion of the actual signal. A perfect match to both the instrument and the test device eliminates reflected test signals. The signal should be effectively coupled into the test device, rather than leaking around the device and resulting in crosstalk from input to output. Repeatable connections are necessary to ensure consistent data.

Realistically, it is impossible to build an ideal fixture, especially at high frequencies. However, it is possible to optimize the performance of the test fixture relative to the performance of the test device. If the fixture's effects on the test signal are relatively small compared to the device's parameters, then the fixture's effects can be assumed to be negligible. For example, if the fixture's loss is much less than the acceptable measurement uncertainty at the test frequency, then it can be ignored.

Measuring Optical Devices

Measuring Optical Devices

In this chapter, you'll learn how to perform measurements on optical devices. Examples of specific measurements are included. Additional measurement capabilities are available using display markers. To learn about these tools, refer to "Measuring with Markers" on page 7-1.

Always perform error corrections

Before making a measurement, you must correct the test setup for any systematic errors at the current measurement settings. Refer to "Procedures for Error-Correcting Measurements" on page 13-21 for the procedures. These procedures require that calibration kits, which mathematically describe test setup components, be saved in the HP 8702D's internal memory. Most of these calibration kits have already been loaded at the factory. To learn about calibration kits, refer to Chapter 13, "Performing Calibrations".

Isolate the lightwave source

Avoid measuring devices that reflect greater than approximately -14 dBm back into the laser, because the laser is sensitive to reflections. If necessary, use a well-matched optical attenuator between the laser source and the test device. Or, use an optical isolator to minimize or eliminate the laser sources reflection sensitivity response. Whenever possible, use optically isolated lightwave sources with low optical reflections ($RL > 35$ dB) to minimize effects of reflection sensitivity and to maximize measurement repeatability and accuracy.

What you'll find in this chapter

Making Transmission Measurements 5-4

To measure a fiber-optic cable 5-5

Making Reflection Measurements 5-8

To measure optical reflection from a fiber cable 5-9

Making Time Domain Measurements 5-14

To measure the length of a single-mode cable 5-16

To measure 2.5 cm between a splice and cleave 5-21

To measure pulse dispersion on a multimode cable 5-27

Making Transmission Measurements

The examples in this section show you how to perform measurements on the following device type:

- Cables, filters, and etcetera—Optical-to-optical (O/O) devices

Basic Measurement Sequence

Each measurement involves the following basic steps.

- 1** Press the PRESET key to return the HP 8702D to a known state.
- 2** Connect your test device to the HP 8702D.
- 3** Choose the settings that are appropriate for the intended measurement.
 - measurement type
 - frequencies
 - number of points
 - power
 - measurement sweep time
 - measurement sweep type (linear or logarithmic frequency)
 - measurement trace format
- 4** Make adjustments to the parameters while you view the device response.
- 5** Press the CAL key to perform a measurement calibration.

The calibration corrects errors using a known set of standards. An error-correction establishes a magnitude and phase reference for the test setup and then reduces systematic measurement errors. Refer to “Types of error-correction” on page 13-18 for error correction types.
- 6** Reconnect the device under test.
- 7** Use the markers to identify various device response values.
- 8** Store the measurement data to a disk.
- 9** Generate a hardcopy with a printer or plotter.

To measure a fiber-optic cable

In this example, the device under test is a roll of single-mode fiber optic cable about 1 kilometer long. The result of this measurement will be a plot of insertion loss versus modulation frequency, indicating the exact frequency at which the 3 dB roll-off point occurs.

NOTE

You can use a different length of single mode cable, but it should be as close to 1 km as possible. However, you may have to increase the sweep time slightly for longer cable lengths. As you will see in this example, the sweep time is set to 3.5 seconds, which is more than adequate for one kilometer of cable. One way to determine if sweep time is long enough is to set it and then increase or decrease the sweep time (with the device under test connected) until a change in the displayed results indicates that the setting is incorrect.

- 1 Connect the system with the thru optical cable as shown in Figure 5-1. Do *not* connect the device under test.

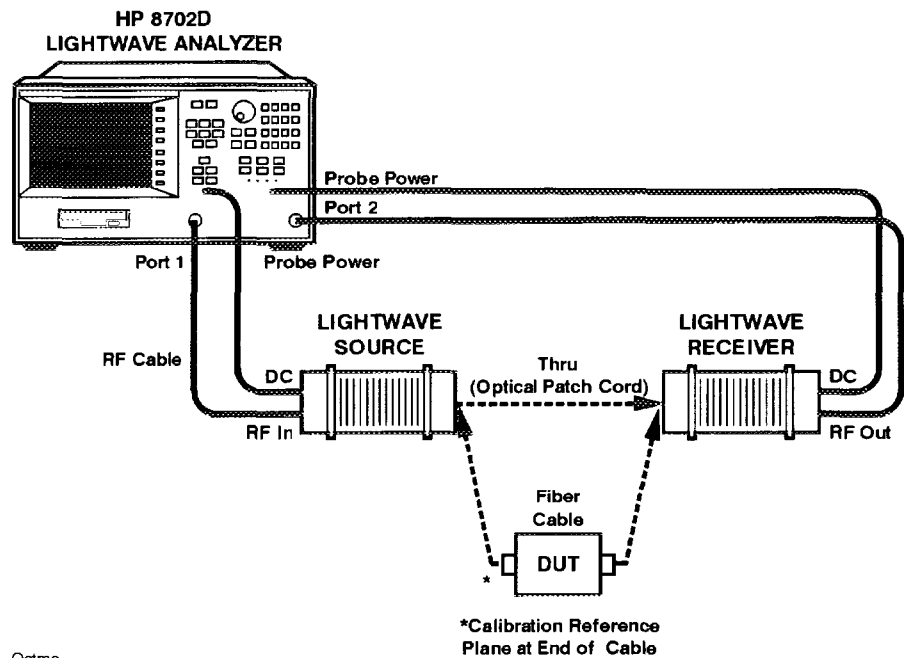

OctmC

Figure 5-1. Optical Cable Transmission Measurement Configuration

Making Transmission Measurements

- 2 To select the type of measurement, press:

PRESET, MEAS, *LIGHTWAVE PARAMETERS*, *Trans: O/O (PORT 1→2)*

- 3 To set the modulation start and stop frequencies, press:

START, 300, k/m

STOP, 700, M/μ

NOTE

This modulation bandwidth was selected for this type of cable. If desired, you may use the full band.

- 4 To set the sweep time, press:

MENU, *SWEEP TIME*, 3.5, x1

The sweep time selected must be long enough to allow each modulation frequency to propagate down the fiber and be properly sampled by the receiver. Approximate the amount of sweep time you will need. In this case, with 201 data points (preset default) and 15 ms per point, about 3.5 seconds is enough for the measurement of the low loss 1 kilometer cable.

$$15 \text{ ms} \times 201 \text{ points} = 3.1 \text{ s (use 3.5)}$$

If the device under test had delay or extreme length, extra sweep time would be required.

- 5 To set the source power to give enough dynamic range for measuring the low loss line, and to select the log sweep type to get a better view of the bandwidth response on the display, press:

POWER, 4, x1

RETURN, *SWEEP TYPE MENU*, *LOG FREQ*

- 6 Connect a thru cable between the source and receiver. The HP 8702D shows the response of the entire measurement system. If you connected your device under test, the measurement would include the device under test's response added to the response now being displayed.

- 7 To perform a response calibration to remove the system's response from your measurement, press:

CAL, *CALIBRATE MENU*, *RESPONSE*, *THRU*

The thru cable acts as the optical thru standard, which is already defined in the HP 8702D calibration kit.

When the analyzer finishes the measurement, it will beep and underline the *RESPONSE* key.

The measured data is now normalized, setting the magnitude values to unity or 0 dB. The HP 8702D shows the notation *Cor* to the left of screen, indicating that the calibration (error-correction coefficient) is active.

The HP 8702D displays the trace as a flat line across the graticule. The end of the thru cable, connected to the receiver, is now the measurement reference plane.

- 8** To measure the cable, connect the roll of fiber between the cable and the receiver, using the appropriate connectors.

All connections should be clean and undamaged. Refer to "Cleaning Connections for Accurate Measurements" on page 1-33.

After one complete measurement sweep, the transmission response of the single mode fiber roll will be displayed on the display.

- 9** To better view the results on the display, press:

SCALE REF, AUTO SCALE

- 10** To place the marker on the 3 dB point, press:

MARKER FCTN, MKR SEARCH, TARGET

The results of this example show that the bandwidth of the roll of fiber cable is approximately 470 MHz. Any modulation frequency above that point would be attenuated past the half-power point.

- 11** To read the trace value at any modulation frequency, press:

MARKER, all OFF, MARKER 1

MARKER FCTN, MKR SEARCH, SEARCH:MAX

MARKER, MKR ZERO

MARKER FCTN, MKR SEARCH, TARGET, -3, x1

Use the front panel knob or the arrow keys to go to a particular frequency or to set the marker to the 3 dB point. The marker amplitude (dB) will be shown at the top right side of the display.

Refer to Chapter 7, "Measuring with Markers" for more information of marker features.

Making Reflection Measurements

The examples in this section show you how to perform the following measurements:

- Optical reflection from a fiber cable—Optical-to-optical (O/O) device

To measure optical reflection from a fiber cable

This measurement configuration is similar to a transmission measurement because modulated light is input to the device under test. The difference is that the lightwave source drives the input of the optical coupler and the lightwave receiver measures the light captured by the coupled arm, light reflected from the test device. An optical coupler separates the forward-going light from the reverse-traveling light, including the modulation signal imposed on the lightwave carrier signal. By measuring the amount of reflected modulation signal in the coupled arm, the HP 8702D shows how much light is being reflected back.

This example will demonstrate how to make a simple optical reflection measurement of a short length of cable (3 meters). This example will also help you verify that you have the system properly connected and properly calibrated.

- 1 Connect the system as shown in Figure 5-2, but do *not* connect the device under test. Turn on the power.

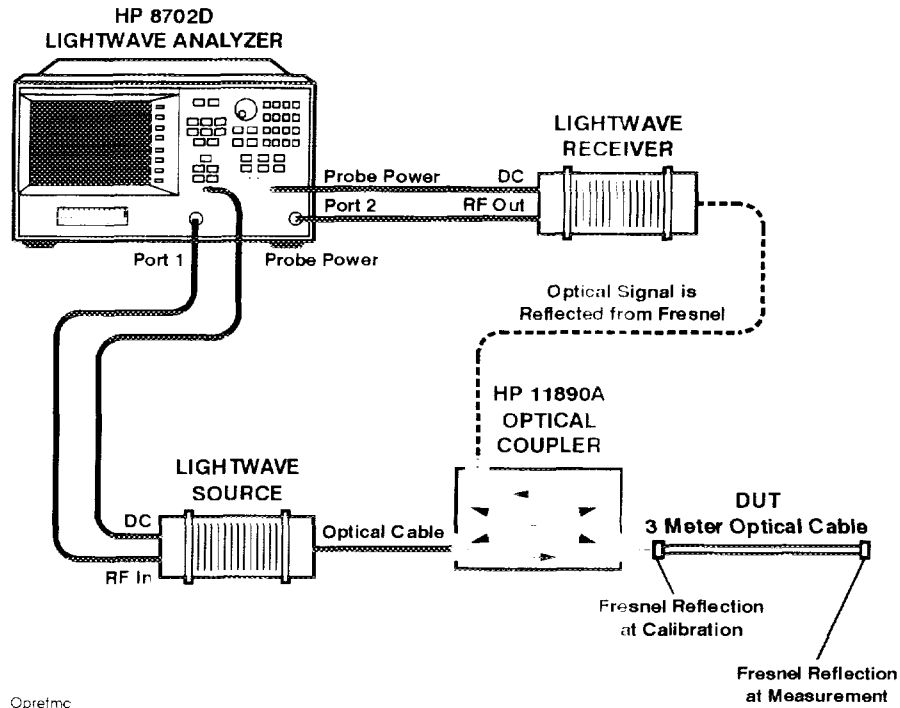

Figure 5-2. Optical Reflection Measurement Configuration

- 2 Begin the measurement sequence by selecting the guided setup and choosing a reflection measurement of a one-port device (the short cable) by pressing:

PRESET

GUIDED SETUP, then follow the on-screen instructions for *1-PORT OPTICAL*.

The connection diagram shown on the screen has the device under test connected to the coupler. However, do *not* connect the device under test yet, because you are going to calibrate the system with a Fresnel reflection on the coupler test port as shown in Figure 5-2.

- 3 Press *CONTINUE* to exit the diagram.

Leave the start and stop frequencies and the number of points in their preset state: 300 kHz to 3 GHz, or 6 GHz optionally. This wide frequency span provides the necessary resolution when converting to the time domain. Refer to "Making Time Domain Measurements" on page 5-14 for more information on time domain responses and their relationship to the frequency domain.

- 4 Set the sweep time and the source power (201 points will require about 3.5 seconds). Also, reflection measurements should always be made with the maximum amount of power, here 10 dBm. Follow the guided setup on-screen instructions.
- 5 The measurement calibration will set the measurement reference plane at the optical coupler's output connector (transmitted signal). The reflection of an open fiber, called a Fresnel reflection, has a known response that can be used to calibrate the system. For reflection measurements, the calibration standard is a Fresnel reflection: the clean output connector of the optical coupler resulting in 3.5% reflected optical power, or about -14.6 dB. After performing the measurement calibration, a measurement reference plane will be established where zero seconds (zero meters) is located at the output connector of the coupler.

Be sure that the coupler's test port connector interface is clean and dry so that a Fresnel reflection (3.5% reflected power) will result during the calibration process. Do not apply any index-matching compounds. Refer to "Cleaning Connections for Accurate Measurements" on page 1-33 for more information on the use of matching compounds.

Be sure that the coupler's reflected (coupled) output is connected to the light-wave receiver. In this configuration, the coupler is going to receive the light coming from the Fresnel reflection to establish the measurement reference plane. The Fresnel reflection is a general purpose standard definition assuming a clean connector interface at the test port. This mathematical definition has already been loaded into the HP 8702D calibration kit at the factory.

- 6 To perform a response calibration, press:

CAL, CALIBRATE MENU, RESPONSE, FRESNEL

When the measurement is complete, the HP 8702D beeps and underlines the *RESPONSE* softkey.

- 7 Examine the response on the display and compare it to Figure 5-3. It should be a flat line (approximately) around -14.6 dB (optical return loss). Again, -14.6 dB is the return loss of the Fresnel reflection, which is related to the fiber's index of refraction and air at the coupler port. The percentage of reflected optical power is calculated as:

$$\left[\frac{n_1 - n_2}{n_1 + n_2} \right]^2 \times 100 = \% \text{ Reflected Optical Power}$$

or, to obtain the dB value, multiply the result by 10_{\log} . In this example,

Making Reflection Measurements

$n_1 = 1.46$ and $n_2 = 1$. Therefore, 3.5% reflected power corresponds to a return loss of -14.6 dB.

NOTE

The smoothing feature can be used to show the underlying shape of the data trace. The averaging feature can be used to reduce the noise displayed on the trace. You can press the AVG key to access these features, then enter a number of averages or a percentage of smoothing span and turn on the respective feature.

If the response is not similar to the one in Figure 5-3, check the connections, reclean the connectors, and repeat the procedure.

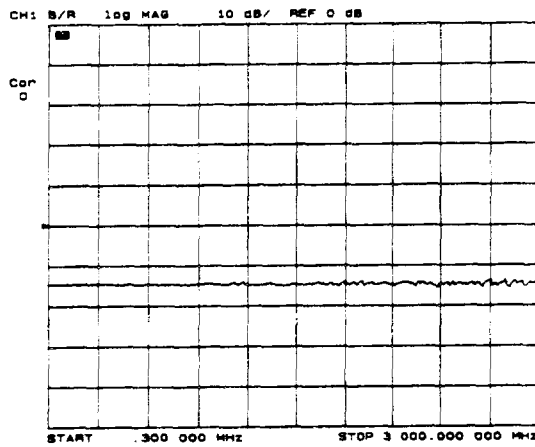

Figure 5-3. Response Calibration with a Fresnel Reflection

- 8 Clean the ends of the short cable device under test (3 meters) and connect it to the coupler's output/input port. Refer to Figure 5-4, and notice the response in the frequency domain. The trace is still at about -14 dB, but shows a ripple pattern caused by the reflected modulated light bouncing back and forth along the path. This effect is sometimes called beating, where re-reflected light is adding and subtracting (as a vector) to the signal as the modulation frequency is varied. The re-reflections occur because of the light bouncing off the end of the short cable (Fresnel), returning back to the coupler, and bouncing back again. This entire re-reflecting process results in the reflections beating against each other.

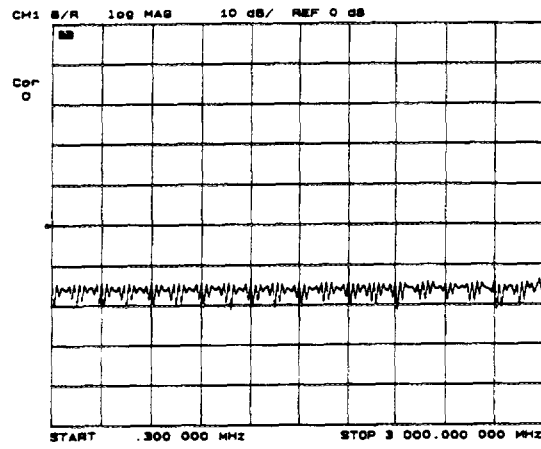

Figure 5-4. Response in the Frequency Domain (beating)

Making Time Domain Measurements

Comparing the HP 8702D to an OTDR

Displaying the reflection coefficient of a network versus time shows the magnitude and location of each discontinuity. Although the HP 8702D can convert frequency domain measurements into time domain measurements, it should not be confused with an optical time domain (OTDR). An OTDR is excellent for measuring fiber discontinuity and backscatter in fiber-optic systems. The HP 8702D is excellent for characterizing components and measuring relative reflections. The following table summarizes the differences and similarities between the capabilities of these two instruments.

Time Domain Comparison

Measurement Capability	HP 8702D	OTDR
Rayleigh backscatter and slope (attenuation vs. length)	no	yes
Connector insertion or splice loss	no ^a	yes
Distance	yes	yes
2-point resolution	2 or 6 cm	> 25 m
Fresnel reflections	yes	yes
Return loss magnitude	yes	no
Transducer characterization of return loss	yes	no
Dead zone	no	yes

a. For transmission measurements, the HP 8702D can make accurate measurements of splices and connectors.

Measuring long fiber-optic cables

The sweep time is the amount of time that it takes for the HP 8702D's RF source to sweep from its start to its stop frequency. For normal measurements, the HP 8702D automatically sets the proper sweep time. However, when measuring a long optical path, such as a roll of fiber-optic cable, the HP 8702D's sweep time should be lengthened. The sweep time must be long enough to allow the instrument to sample the modulation properly. In general, the sweep time should be set to a value equal to the number of measurement points times 15 ms.

To measure the length of a single-mode cable

A practical application of the analyzer is its ability to measure the exact length of a long roll of cable, 44 kilometers (about 24 miles) long.

This measurement configuration is very similar to a transmission measurement, except that the source drives the input of the coupler, and the receiver measures the light captured by the coupled arm — this is light reflected from the test device. The coupler separates the forward going light from the reverse traveling light. By measuring the amount of reflected modulation in the coupled arm, the analyzer shows how much light is being reflected back. The time domain is then used to convert the frequency response into a time and distance response.

- 1 Connect the system as shown in Figure 5-5. You will have to clean the connectors on the coupler and also clean the connectors on the cables for the most accurate results. Refer to “Cleaning Connections for Accurate Measurements” on page 1-33.

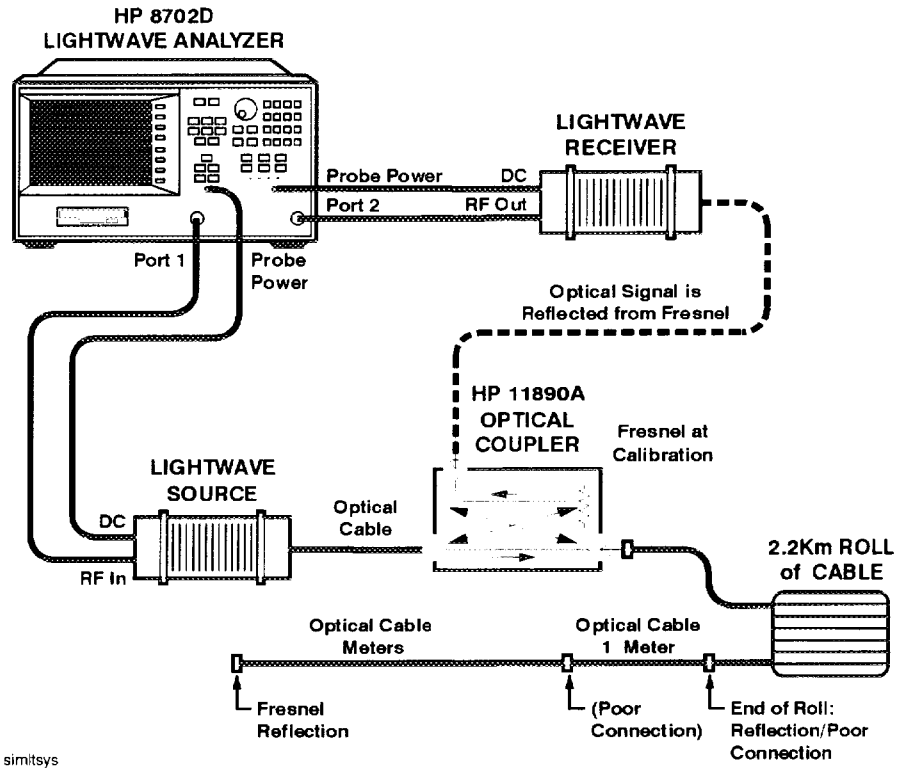

simitsys
Figure 5-5. Simulated Lightwave System Fault Location Configuration

- 2 Set up the instrument parameters in the frequency domain by pressing:

```

PRESET
MEAS, LIGHTWAVE PARAMETERS, Refl: 0 (PORT1→2)
AVG, IF BW, 10, x1
CAL, MORE, INDEX of REFRACTION, 1.46, x1
    
```

The IF bandwidth is decreased as low as possible because the reflected signal will be quite low compared to the incident signal. The lower IF bandwidth will filter out noise and lower the noise floor. The index of refraction is set to 1.46. By setting the index of refraction, the velocity factor is automatically calculated and set by the analyzer as they are the inverse of each other.

Making Time Domain Measurements

- 3 Set the stimulus block functions by pressing:

MENU, POWER, 10, x1, RETURN
SWEEP TIME, 3.5, x1
NUMBER of POINTS, 801, x1

Note that the sweep time setting has not taken account of the length of the cable. However, when 801 data points are selected, the analyzer will automatically reset the sweep time to about 83 seconds because it knows how much time it takes to measure that many data points. This number of data points will also give better resolution when converted from frequency domain to time domain.

CENTER, 1, M/ μ
SPAN, 1.4, M/ μ

- 4 Calibrate the system. You are going to make a measurement calibration that will set the measurement reference plane at the optical coupler's output connector (transmitted signal). The reflection off the open fiber, called a Fresnel reflection, has a flat response that can be used to calibrate the system. For reflection measurements, the Fresnel is actually the clean OUTPUT/INPUT connector of the optical coupler, about 3.5% reflected optical power or about 14.6 dB. After calibration, the roll of cable that you connect will have a measurement reference plane at that connection.

Be sure that all connectors are clean and dry, without any matching gel or oil on them, as matching compounds can reduce reflections. Refer to "Cleaning Connections for Accurate Measurements" on page 1-33.

Be sure that the coupler's reflected (coupled) output is connected to the receiver. In this configuration, the coupler is going to receive the light coming from the Fresnel reflection to establish the measurement reference plane.

Press:

CAL, CALIBRATE MENU, RESPONSE, FRESNEL

When the calibration measurement is complete, the analyzer beeps and underlines the *RESPONSE* softkey. Then, press:

SAVE/RECALL, SELECT DISK, INTERNAL MEMORY, RETURN, SAVE STATE

The Fresnel reflection is a general purpose standard definition assuming a clean Fresnel reflection at the test port. This mathematical definition has already been loaded into the analyzer.

Now press: MEAS

Examine the response on the display. It should be a flat line around -14.6 dB, the optical return loss of the Fresnel reflection (3.5% reflected optical power). This value always depends upon the index of refraction of the fiber, in this case 1.46.

Noise on top of the trace may be observed. That noise is caused by reflected light reentering the laser cavity and changing its modulation characteristics. This is called reflection sensitivity.

- 5** To measure the roll of cable to determine its exact length, be sure the cable is terminated with a Fresnel reflection so that enough light can return down the fiber and enter the coupler. You must have the proper connectors on the cable to connect it to the coupler's transmitted output. The source and receiver will remain connected in their present positions.
 - a** Connect the roll of cable.
 - b** After one complete sweep, look at the response in the frequency domain. Use the *SCALE REF*, *AUTO SCALE* keys to auto scale the trace, if necessary.
 - c** Convert the measurement to time domain by pressing:
SYSTEM, TRANSFORM MENU, TRANSFORM ON
- 6** The response should now show two distinct peaks on the trace. One peak is the signal at zero seconds (calibrated reference planes), where it leaves the coupler's transmitted output connector at time zero or zero meters. The next peak is where the lightwave signal has hit the Fresnel reflection, at the end of the cable.

Making Time Domain Measurements

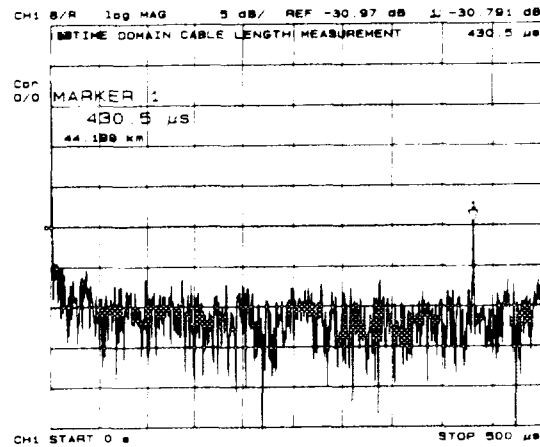

Figure 5-6. Cable (44 km) Measurement Results

The signal has loss in each direction due to the long length of the cable, and another 14.6 dB of loss due to the Fresnel reflection. Therefore, most of the measurement signal received by the analyzer is greater than -40 dB, except where the reflected signal occurs.

The marker can be used to locate the end of the fiber if the distance you read is adjusted for the actual velocity of light in the fiber. Light travels down the fiber at about 2/3 the speed of light in free space. Although the velocity factor is automatically set when the index of refraction is set, this can also be done by pressing:

CAL, MORE, VELOCITY FACTOR, 0.66, x1.

To measure 2.5 cm between a splice and cleave

This procedure requires an HP 8702D with Option 006. The Option 006 allows measurements to be made with modulation frequencies up to 6 GHz.

The 6 GHz system uses an HP 83402A lightwave source and an HP 83411C lightwave receiver (non-amplified). This 1300 nm SMF source and receiver combination can modulate and demodulate the lightwave carrier up to 6 GHz.

This increase in modulation frequency allows measurements to be made with greater resolution and bandwidth response, especially useful for characterizing E/O and O/E devices. This measurement example demonstrates the system's resolution capabilities.

The 6 GHz option provides greater two-point resolution (less than 2 cm) when using time domain. With Option 006 firmware, the system will have a default frequency range of 300 kHz to 6 GHz.

An HP optical coupler (for example, an HP 11890A) is also used here to measure the Fresnel reflection from the end of the short device under test used in this example.

The device under test used in this example demonstrates the time domain resolution capabilities of the 6 GHz system. The device under test is a one-port SMF cable (index of refraction = 1.46), approximately 12.5 cm total length. It has an FC/PC connector on the connecting end and a cleave resulting in a Fresnel reflection (3.5%) on the other end. In addition, there is an AT&T mechanical splice 2.5 cm back from the Fresnel end.

The 6 GHz capability is used in conjunction with the calibration procedure to establish a measurement plane at 0 cm and 0 seconds. Then, the device under test is loosely connected (FC/PC) to the coupler port (reference plane). After the measurement sweep, the display shows the FC/PC connection at 0 cm, the mechanical splice at 10 cm, and the Fresnel reflection from the cleave at the end of the fiber.

1 Connect the system as shown in Figure 5-7.

Make sure that all of the connections are clean. Refer to "Cleaning Connections for Accurate Measurements" on page 1-33.

The optical coupler's output/input port should be cleaned so that its fiber end will have a Fresnel reflection of 3.5% optical power.

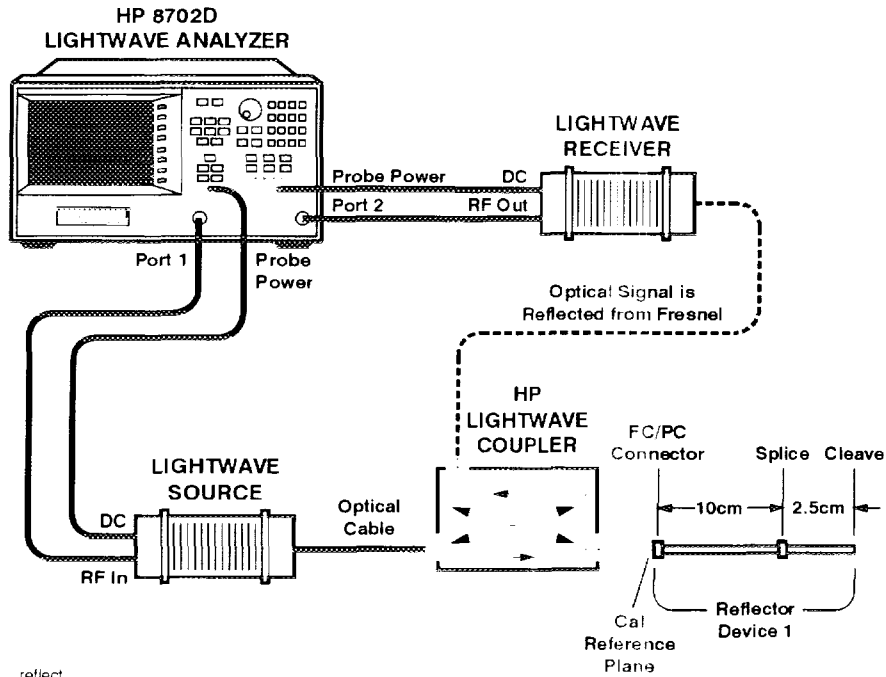

reflect
Figure 5-7. Reflection Test Setup

- 2 Select the measurement type, number of points, and IF bandwidth required by pressing:

```

PRESET
MEAS, LIGHTWAVE PARAMETERS, Refl: 0 (PORT 1→2)
MENU, NUMBER of POINTS, 401, x1
POWER, 10, x1
AVG, IF BW, 10, x1
    
```

The sweep time will be automatically set to about 41 seconds because the smaller IF bandwidth setting (used to lower the noise floor) and the 401 points require this much time to make a measurement sweep. In addition, the 6 GHz system has a default frequency setting of 300 kHz to 6 GHz, which is used in this example.

- 3 Select the low pass mode for time domain and perform a response calibration by pressing:

```

SYSTEM, TRANSFORM MENU, SET FREQ LOW PASS
    
```

The low pass selection will change the RF modulation frequency range. The

start frequency is readjusted to about 14 MHz.

Before continuing the calibration process, be sure that the fiber end of the coupler's output/input port is clean and dry so that a good reflection will result (3.5% reflected optical power). Refer to "Cleaning Connections for Accurate Measurements" on page 1-33.

Continue by pressing:

CAL, CALIBRATE MENU, RESPONSE, FRESNEL

After the sweep, the HP 8702D will beep and underline the word RESPONSE on the display.

To save the calibration, press:

SAVE/RECALL, SELECT DISK, INTERNAL MEMORY, RETURN, SAVE STATE

Now press: MEAS

The display should now show a trace at about -14.6 dB, similar to the plot shown in Figure 5-8. This is the corrected frequency domain response of the Fresnel reflection. The trace may have a slight amount of fine-grain ripple. The output/input port of the coupler is now the reference plane for the device under test to be measured.

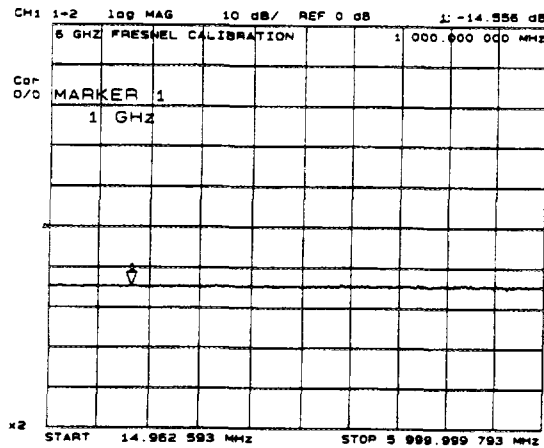

Figure 5-8. 6 GHz Fresnel Reflection Calibration

Making Time Domain Measurements

- 4 Select the time domain transform feature by pressing:

SYSTEM, *TRANSFORM MENU*, *LOW PASS IMPULSE*

The low pass impulse selection is used to mathematically simulate an impulse. The narrow width of the impulse response is used because it gives better resolution than the bandpass mode.

Continue by pressing:

CAL, *MORE*, *INDEX of REFRACTION*, 1.46, x1

The response resolution is about 16 mm or 1.6 cm, using the 6 GHz frequency range.

Continue by pressing:

SYSTEM, *TRANSFORM MENU*, *TRANSFORM ON*, *RETURN*

The display will now show the impulse response out to the Fresnel reflection.

- 5 Adjust the display. Change the span to 3 nanoseconds, the center to 750 picoseconds, and the format to linear magnitude to better view the trace by pressing:

FORMAT, *LIN MAG*

SPAN, 3, G/n

CENTER, .750, G/n

Set the marker to 0 seconds (0 meters) to locate the Fresnel reflection at the coupler output/input port. This is the time domain measurement reference plane (0 seconds and 0 meters), where you will connect the device under test. Press:

MARKER, *MARKER 1*, 0, x1

Because the approximate 12.5 cm device under test has an AT&T mechanical splice about 10 cm from the FC/PC connector, and about 2.5 cm of fiber beyond that (with a cleave for 3.5% reflected power), you can also set markers 2 and 3 to those positions before attaching the device under test.

Set markers 2 and 3 by pressing:

MARKER 2, 1, G/n

MARKER 3, 1.25, G/n

The display should look similar to the plot shown in Figure 5-9.

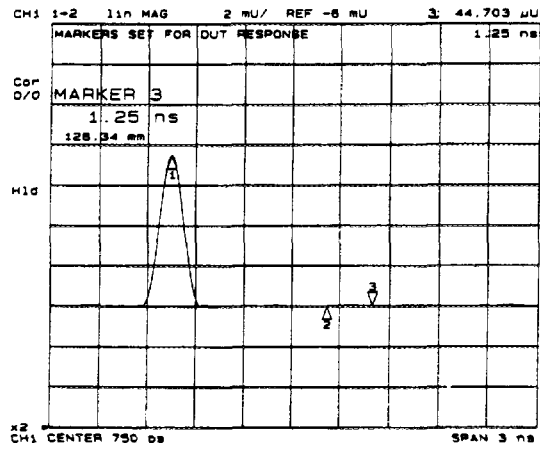

Figure 5-9. Markers Set for Device Under Test Measurement

- 6 Connect the device under test. Carefully attach the FC/PC end of the device under test to the coupler output/input port so that it is loosely connected. The quality of this connection will determine the magnitude of the device under test response at the reference plane (0 meters/0 seconds) and at the other peaks.

Making Time Domain Measurements

After the device under test is connected, and after the measurement sweep is completed, the results should be similar to the plot in Figure 5-10. If three distinct peaks are not seen, readjust the FC/PC connection by loosening or tightening it. View the response after the next measurement sweep. Repeat this process if necessary.

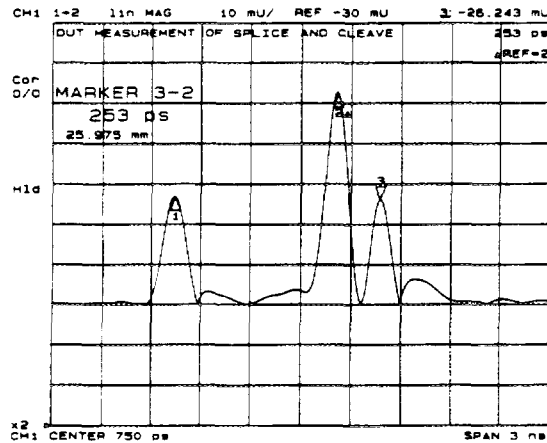

Figure 5-10. Device Under Test Measurement of Splice and Cleave

The distance between the splice (marker 2) and the cleave (marker 3) can be determined by moving the markers to the respective peaks and reading the response from the display, using the delta marker mode. The markers can be moved to the peak tops by selecting each marker and adjusting the knob to position the marker.

The distance between the peaks can be read by pressing:

MARKER, Δ MODE MENU, Δ REF=2

or referenced to the last marker selected.

To measure pulse dispersion on a multimode cable

Pulse dispersion is a measure of the amount of change in the width of a modulation frequency pulse. The change is due to the cumulative dispersive effects in the transmission path, especially in multimode fibers. Although pulse dispersion can be derived from the bandwidth of a device under test, this measurement also demonstrates the split screen display, data storage into memory, and many other features of the analyzer.

In this example, time domain is used to convert the frequency domain data into the impulse response of the device under test. Here, pulse dispersion is calculated as:

$$\text{Pulse Dispersion (s/km)} = \sqrt{\text{transmitted signal}^2 - \text{incident signal}^2}$$

Pulse dispersion measurements must be made using a frequency span that is equal to the bandwidth of the fiber.

- 1 Measure the bandwidth of the fiber cable. In this example, the bandwidth was measured at about 1 GHz.
- 2 Connect the system as shown in Figure 5-11.

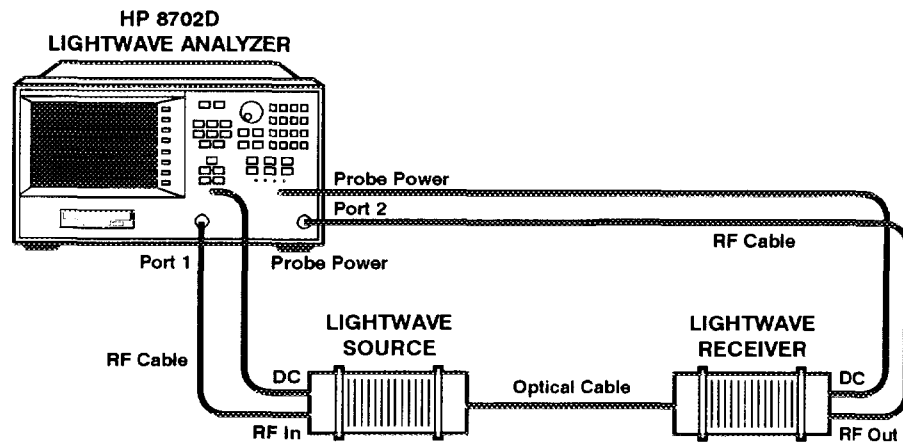

tstwo

Figure 5-11. Pulse Dispersion Test Setup

- 3 Perform a response calibration. The number of points is increased to 401 to give better resolution. The power is set to 10 dBm to compensate for any loss through the cable and the IF bandwidth is set to 300 Hz to reduce the noise. Because of the increased number of points and the IF bandwidth reduction, the sweep time must be increased to 8 seconds in this example.

Press the following keys on the analyzer:

```
PRESET  
MEAS, LIGHTWAVE PARAMETERS, Trans: O/O S21 (PORT 1→2)  
STOP, 1, G/n  
MENU, POWER, 10, x1, RETURN  
SWEEP TIME, 8, x1  
NUMBER of POINTS, 401, x1  
AVG, IF BW, 300, x1  
CAL, MORE, INDEX of REFRACTION, 1.46, x1, RETURN  
CALIBRATE MENU, RESPONSE, THRU
```

After the thru standard is measured, the analyzer will beep and underline *RESPONSE*.

The trace should now be a flat line in the frequency domain at 0 dB. You can also save this calibration in a register.

NOTE

Because the sweep time is 8 seconds, the response of the system to front panel commands will not be extremely rapid. Therefore, execute the following procedures somewhat slowly to obtain the best results.

4 In order to view the time domain response of the incident signal, press:

SYSTEM, *TRANSFORM MENU*, *TRANSFORM ON*
FORMAT, *LIN MAG*
SCALE REF, *AUTO SCALE*
SPAN, 8, G/n
MARKER
MARKER FCTN, *MKR SEARCH*, *SEARCH:MAX*
MARKER, *MKR ZERO*
MARKER FCTN, *MKR SEARCH*, *WIDTH VALUE*, 0.5, x1, *WIDTHS ON*

The response should be similar to the plot shown in Figure 5-12.

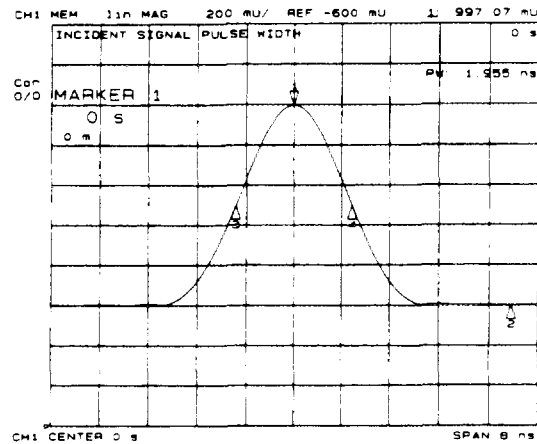

Figure 5-12. Incident Signal Pulse Width

Making Time Domain Measurements

- 5 Store the data into memory and split the display for comparison of the incident and transmitted signal pulse widths by pressing:

DISPLAY, DATA→MEMORY, DISPLAY: MEMORY
MENU, COUPLED CH OFF
DISPLAY, DUAL CHAN ON
MARKER FCTN, MARKER MODE MENU, MARKERS: UNCOUPLED

and, if desired, save the channel 1 data in a register.

Connect the device under test (roll of multimode fiber cable). Be sure to connect the cable interface directly to the lightwave source. Connect the other end of the device under test to the short cable that is connected to the lightwave receiver.

- 6 Locate the end of the cable in time domain. Use the marker function, in the time domain, and note the uncorrected length.

CHAN 2
MEAS, LIGHTWAVE PARAMETERS, Trans: O/O (PORT 1→2)
SYSTEM, TRANSFORM MENU, TRANSFORM ON

Decrease the stop frequency, using the transform menu, until the range is slightly beyond the length of the cable by pressing:

SYSTEM, TRANSFORM MENU, TRANSFORM PARAMETERS, STOP FREQUENCY, 50, M/μ

Notice that the range is now about 1.6 km, then press:

RETURN, *STOP*, and press the \uparrow (up arrow) key until the stop time/range is slightly greater than the length of the roll of cable. In this example, the stop time is about 8 μ s and the length is about 1.6 km. Press:

MARKER FCTN, *MKR SEARCH*, *SEARCH: MAX*

The marker now shows the location of the transmitted pulse in the time domain (LOG MAG) at the end of the cable, similar to Figure 5-13.

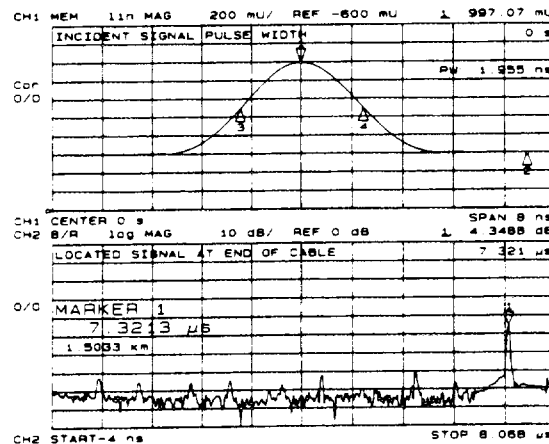

Figure 5-13. Location of Transmitted Signal at End of Cable

- Center the peak and use the marker function, in combination with the display scaling features, to focus on the transmitted signal pulse width by pressing:

RETURN, *MARKER* → *CENTER*, *MKR SEARCH*, *SEARCH: MAX*

The marker will move off of the center (max) of the peak because of the spacing of the data points (number of points). This is expected. Then, after converting to a linear format, use the scaling feature and the span feature to focus on the signal by pressing:

FORMAT, *LIN MAG*
SCALE REF, *AUTO SCALE*

Making Time Domain Measurements

If necessary, decrease the span by pressing the down arrow key, ↓, one time and then readjust the scaling again by pressing:

SPAN, ↓
SCALE REF, *AUTO SCALE*
MARKER FCTN, MKR SEARCH, SEARCH: MAX, RETURN, MARKER → CENTER

Do not decrease the span too much. If you do, the true response may not be displayed because it is off the display. If you know the cable length, you can look at the marker value to be sure it is on the proper response peak.

- 8** Turn correction on, turn the alias span on, and adjust the display trace by pressing:

CAL, *CORRECTION ON*
SCALE REF, *AUTO SCALE*
SYSTEM, TRANSFORM MENU, MORE, ALIAS SPAN ON

The alias span is used so that electrical delay (mathematically adding electrical length) is not required. The frequency bandwidth limitation does not allow you to look out to the end of the cable. However, by turning the alias span on, you can go look out far enough and view the correct response.

In addition, the correction coefficients will almost certainly change the displayed data. When you turn on the calibration, the start and stop frequencies set will return to their previous settings; in this case, 300 kHz to 1 GHz, and the peak (max) signal at the end of the cable will no longer be in the center of the display where the marker has been set. Therefore, readjust the marker, scaling, and the span so that the transmitted signal is centered.

Display adjustment technique

The following technique is a suggested method of adjusting the trace display. Although each device under test will have a different response, the following method can be used.

- a** The following procedure will center the trace and put the marker on the peak value by pressing:

MARKER FCTN, MKR SEARCH, SEARCH: MAX, RETURN
MARKER → CENTER, MKR SEARCH, SEARCH: MAX

- b** Use the scaling feature to properly adjust the graticule values and the span. Do *not* decrease the span below the value used on channel 1. Press:

SCALE REF, *AUTO SCALE*
SPAN, ↓

- c Be sure you have the marker on the correct response and repeat Step a and Step b above until the pulse width is displayed similar to the trace on channel 1. Then, set the pulse width markers and reduce span so that it matches or is close to the span on channel 1. If necessary, change the span on channel 1 to match by pressing:

SPAN, 10, G/n

Then set the markers by pressing:

MARKER FCTN, *MARKER*→*SPAN*

As shown in the plot in Figure 5-14, the span of channel 1 was set to 10 ns to match channel 2 and allow easy analysis of the data at 1 ns per division.

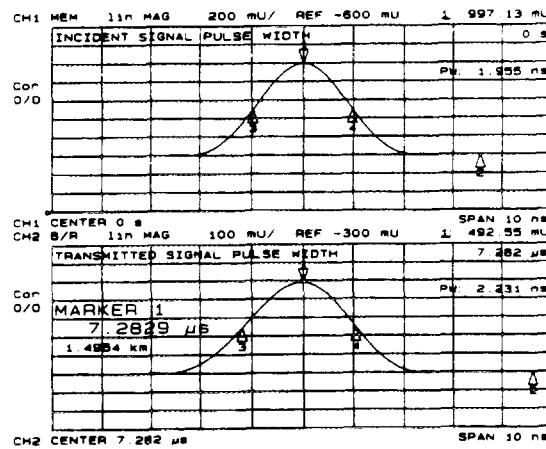

Figure 5-14. Pulse Width Signal Comparison

Making Time Domain Measurements

- 9 To calculate the actual dispersion, in seconds/km, the following equation can be used:

$$Dispersion = \sqrt{transmitted^2 - incident^2}$$

where the transmitted and incident signal values are the measured pulse widths in seconds.

In this example, the pulse dispersion PD is calculated as:

$$PD = \sqrt{(2.231 ns)^2 - (1.955 ns)^2}$$

$$PD = \sqrt{(4.9774 ns^2) - (3.822 ns^2)}$$

$$PD = \sqrt{1.1554 ns^2}$$

$$PD = 1.0749 ns \text{ for } 1.4954 \text{ km cable length}$$

$$Pulse Dispersion = 0.7188 ns \text{ per km MMF}$$

Optimizing Measurements

Optimizing Measurements

In this chapter, you'll learn how to change the display format, increase measurement accuracy, display and save traces, increase sweep speed, increase dynamic range, reduce trace noise, and reduce receiver crosstalk.

What you'll find in this chapter

Display Functions	6-4
Increasing Measurement Accuracy	6-9
Changing the Display Format	6-12
To select the display format	6-20
Displaying and Saving Traces	6-21
Increasing Sweep Speed	6-25
Increasing Dynamic Range	6-30
Reducing Trace Noise	6-32
Reducing Receiver Crosstalk	6-37
Knowing the Instrument Modes	6-38

Display Functions

The DISPLAY key provides access to the memory math functions, and other display functions including dual channel display, active channel display title, frequency blanking, display intensity, background intensity, and color selection.

The analyzer has two available memory traces, one per channel. Memory traces are totally channel dependent: channel 1 cannot access the channel 2 memory trace or vice versa. Memory traces can be saved with instrument states: one memory trace can be saved per channel per saved instrument state. There are up to 31 save/recall registers available, so the total number of memory traces that can be present is 64, including the two active for the current instrument state. The memory data is stored as full precision, complex data.

NOTE

You may not be able to store 31 instrument states if they include a lot of calibration data. The calibration data contributes considerably to the size of the instrument state file and, therefore, can use all the available memory prior to filling all 31 registers.

Two trace math operations are implemented, data/memory and data-memory. (Note that normalization is data/memory not data-memory.) Memory traces are saved and recalled and trace math is done immediately after error correction. This means that any data processing done after error correction, including parameter conversion, time domain transformation, scaling, etc., can be performed on the memory trace. Trace math can also be used as a simple means of error correction, although that is not its main purpose.

All data processing operations that occur after trace math, except smoothing and gating, are identical for the data trace and the memory trace. If smoothing or gating is on when a memory trace is saved, this state is maintained regardless of the data trace smoothing or gating status. If a memory trace is saved with gating or smoothing on, these features can be turned on or off in the memory-only display mode.

The actual memory for storing a memory trace is allocated only as needed. The memory trace is cleared on instrument preset, power on, or instrument state recall.

If sweep mode or sweep range is different between the data and memory traces, trace math is allowed, and no warning message is displayed. If the number of points in the two traces is different, the memory trace is not displayed nor rescaled. However, if the number of points for the data trace is changed back to the number of points in the memory, the memory trace can then be displayed.

If trace math or display memory is requested and no memory trace exists, the message, **CAUTION: NO VALID MEMORY TRACE**, is displayed.

Dual channel mode

The *DUAL CHAN ON OFF* softkey toggles between display of both measurement channels or the active channel only. This is used in conjunction with *SPLIT DISP ON* in the display more menu to display both channels. With *SPLIT DISP OFF*, the two traces are overlaid on a single graticule (refer to Figure 6-1a). With *SPLIT DISP ON*, the measurement data is displayed on two half-screen graticules one above the other (refer to Figure 6-1b). Current parameters for the two displays are annotated separately.

The stimulus functions of the two channels can also be controlled independently using *COUPLED CH ON OFF* in the stimulus menu. In addition, the markers can be controlled independently for each channel using *MARKERS: UNCOUPLED* in the marker mode menu.

Dual channel mode with decoupled channel power

By decoupling the channel power or port power and using the dual channel mode, you can simultaneously view two measurements having different power levels. However, there are two configurations that may not appear to function "properly:"

- 1 Channel 1 requires one attenuation value and channel 2 requires a different value. Since one attenuator is used for both test ports, this would cause the attenuator to continuously switch power ranges.
- 2 Channel 1 is driving one test port and channel 2 is driving the other test port. This would cause the test port transfer switch to continually cycle. The instrument will *not* allow the attenuator to continuously switch ranges in order to update these measurements without the direct intervention of the operator.

Optimizing Measurements
Display Functions

If the above condition exists, the test set hold mode will engage, and the status notation ϵsH will appear on the left side of the screen. The hold mode leaves the measurement function in only one of the two measurement paths. To update both measurement setups, press MENU, *MEASURE RESTART*. Refer to Chapter 1, "Getting Started" for more information on this condition.

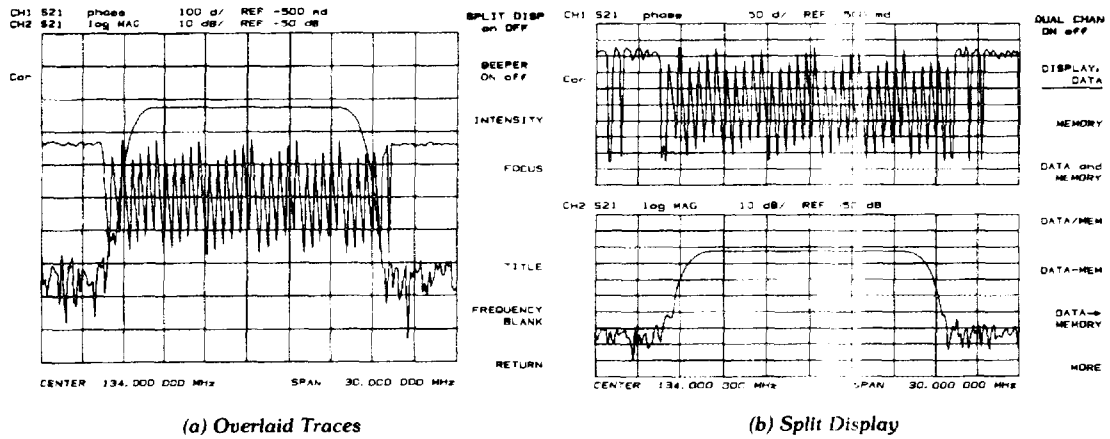

Figure 6-1. Dual Channel Displays

pg6172 c

Adjusting the colors of the display

This procedure explains how to adjust the colors on your analyzer's display. The default colors in this instrument have been scientifically chosen to maximize your ability to discern the difference between the colors, and to comfortably and effectively view the colors. These colors are recommended for normal use because they will provide a suitable contrast that is easy to view for long periods of time.

You may choose to change the default colors to suit environmental needs, individual preferences, or to accommodate color deficient vision. You can use any of the available colors for any of the seven display elements listed by the softkey names below:

- *CH1 DATA/LIMIT LN*
- *CH1 MEM*
- *CH2 DATA/LIMIT LN*
- *CH2 MEM/REF LINE*
- *GRATICULE/TEXT*
- *WARNING*
- *TEXT*

To change the color of a display elements, press the softkey for that element (such as *CH1 DATA*). Then press *TINT* and turn the analyzer front panel knob, use the step keys or the numeric keypad, until the desired color appears.

Color is comprised of three parameters:

- **Tint:** The continuum of hues on the color wheel, ranging from red, through green and blue, and back to red.
- **Brightness:** A measure of the brightness of the color.
- **Color:** The degree of whiteness of the color. A scale from white to pure color.

The most frequently occurring color deficiency is the inability to distinguish red, yellow, and green from one another. Confusion between these colors can usually be eliminated by increasing the brightness between the colors. To accomplish this, press the *BRIGHTNESS* softkey and turn the analyzer front panel knob. If additional adjustment is needed, vary the degree of whiteness of the color. To accomplish this, press the *COLOR* softkey and turn the analyzer front panel knob.

Display Functions

NOTE

Color changes and adjustments remain in effect until changed again in these menus or the analyzer is powered off and then on again. Cycling the power changes all color adjustments to default values. PRESET does not affect color selection.

Setting default colors

To set all the display elements to the factory-defined default colors, press:
DISPLAY, MORE, ADJUST DISPLAY, DEFAULT COLORS

NOTE

PRESET does not reset or change colors to the default color values.

Saving modified colors

To save the modified color set, press:

DISPLAY, MORE, ADJUST DISPLAY, SAVE COLORS

Modified colors are not part of a saved instrument state and are lost unless saved using these softkeys.

Recalling modified colors

To recall the previously saved color set, press:

DISPLAY, MORE, ADJUST DISPLAY, RECALL COLORS

Increasing Measurement Accuracy

Connector repeatability

Connector repeatability is a source of random measurement error. Measurement error-corrections do not compensate for these errors. For all connectors, you should frequently do the following:

- inspect the connectors
- clean the connectors
- gauge the connectors
- use correct connection techniques. Refer to “Cleaning Connections for Accurate Measurements” on page 1-33.

Interconnecting cables

Cables connecting the device under test to the analyzer can contribute random errors to your measurement. You should frequently do the following:

- inspect for lossy cables
- inspect for damaged cable connectors
- practice good connector care techniques
- minimize cable position changes between error-correction and measurements

Temperature drift

Electrical characteristics will change with temperature due to the thermal expansion characteristics of devices within the analyzer, calibration devices, test devices, cables, and adapters. Therefore, the operating temperature is a critical factor in their performance. During a measurement calibration, the temperature of the calibration devices must be stable and within $25 \pm 5^\circ\text{C}$.

- use a temperature-controlled environment
- ensure the temperature stability of the calibration devices
- avoid handling the calibration devices unnecessarily during calibration
- ensure the ambient temperature is $\pm 1^\circ$ of measurement error-correction temperature

Frequency drift

Minute changes in frequency accuracy and stability can occur as a result of temperature and aging (on the order of parts per million).

- override the internal crystal with a high-stability external source, frequency standard, or, if your analyzer is equipped with Option 1D5, use the internal frequency standard.

Performance verification

You should periodically check the accuracy of the analyzer measurements by doing the following:

- perform a measurement verification at least once per year.

Refer to the *HP 8702D Installation Guide* for the measurement verification procedure.

Reference plane and port extensions

Use the port extension feature to compensate for the phase shift of an extended measurement reference plane, due to such additions as cables, adapters, and fixtures, after completing an error-correction procedure (or when there is no active correction).

You can activate a port extension by pressing:

CAL, MORE, PORT EXTENSIONS, EXTENSIONS ON, then enter the delay to the reference plane.

Table 6-1. Differences between PORT EXTENSION and ELECTRICAL DELAY

	PORT EXTENSION	ELECTRICAL DELAY
Main Effect	The end of a cable becomes the test port plane for all S-parameter measurements.	Compensates for the electrical length of a cable. Sets the cable's electrical length x 1 for transmission. Sets the cable's electrical length x 2 for reflection.
Measurements Affected	All S-parameters	Only the currently selected S-parameter.
Electrical Compensation	Intelligently compensates for 1 times or 2 times the cable's electrical delay, depending on which S-parameter is computed.	Only compensates as necessary for the currently selected S-parameter.

Changing the Display Format

The measurement data can be showed on the display in the following formats:

- Logarithmic magnitude
- Linear magnitude
- Polar
- Smith chart
- Phase
- Electrical delay
- Standing wave ratio (SWR)
- Real
- Imaginary

Special display markers are available for measuring data in polar and Smith chart formats. For information on these markers, refer to "Using Markers with Other Display Formats" on page 7-30.

The **FORMAT** key presents a menu used to select the appropriate display format for the measured data. Various rectangular and polar formats are available for display of magnitude, phase, real data, imaginary data, impedance, group delay, and SWR. The units of measurement are changed automatically to correspond with the displayed format. Special marker menus are available for the polar and Smith formats, each providing several different marker types for readout of values.

The format defined for display of a particular S-parameter or input is remembered with that parameter. Thus, if different parameters are measured, even if only one channel is used, each parameter is shown in its selected format each time it is displayed.

The illustrations below show a reflection measurement of a bandpass filter displayed in each of the available formats.

Log magnitude format

The *LOG MAG* softkey displays the log magnitude format. This is the standard Cartesian format used to display magnitude-only measurements of insertion loss, return loss, or absolute power in dB versus frequency. Figure 6-2 illustrates the bandpass filter reflection data in a log magnitude format.

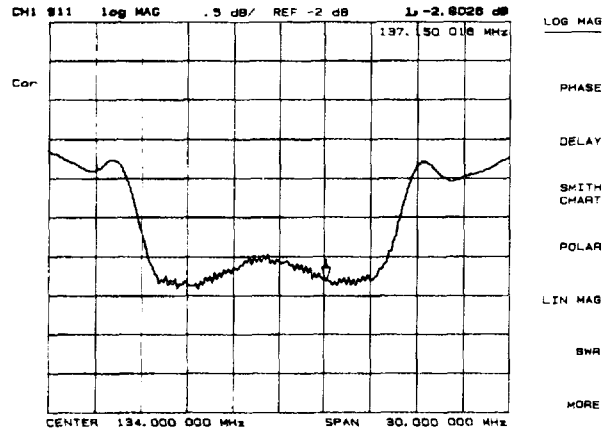

pg6184 c

Figure 6-2. Log Magnitude Format

Phase format

The *PHASE* softkey displays a Cartesian format of the phase portion of the data, measured in degrees. This format displays the phase shift versus frequency. Figure 6-3 illustrates the phase response of the same filter in a phase-only format.

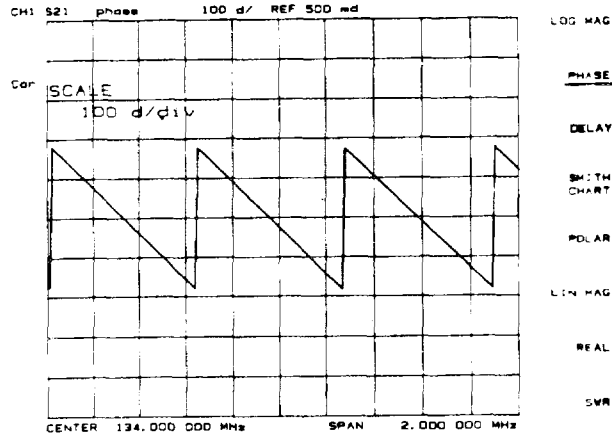

Figure 6-3. Phase Format

page 3 of 3

**Group delay
format**

The *DELAY* softkey selects the group delay format, with marker values given in seconds. Figure 6-4 shows the bandpass filter response formatted as group delay.

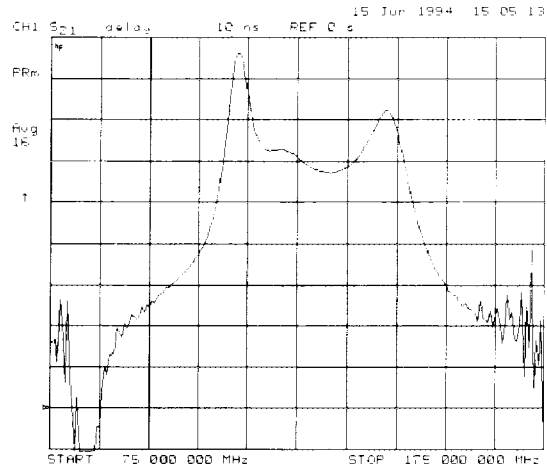

Figure 6-4. Group Delay Format

Smith chart format

The *SMITH CHART* softkey displays a Smith chart format (refer to Figure 6-5a). This is used in reflection measurements to provide a readout of the data in terms of impedance. The intersecting dotted lines on the Smith chart represent constant resistance and constant reactance values, normalized to the characteristic impedance, Z_0 , of the system. Reactance values in the upper half of the Smith chart circle are positive (inductive) reactance, and those in the lower half of the circle are negative (capacitive) reactance. The default marker readout is in ohms (Ω) to measure resistance and reactance ($R+jX$). Additional marker types are available in the Smith marker menu.

The Smith chart is most easily understood with a full scale value of 1.0. If the scale per division is less than 0.2, the format switches automatically to polar.

If the characteristic impedance of the system is not 50 ohms, modify the impedance value recognized by the analyzer by pressing:

CAL, MORE, SET Z0, 50, x1.

An inverted Smith chart format for admittance measurements (refer to Figure 6-5b) is also available. Access this by selecting *SMITH CHART* in the format menu, and pressing MKR, MARKER MODE MENU, SMITH MKR MENU, G+jB MKR. The Smith chart is inverted and marker values are read out in Siemens (S) to measure conductance and susceptance ($G+jB$).

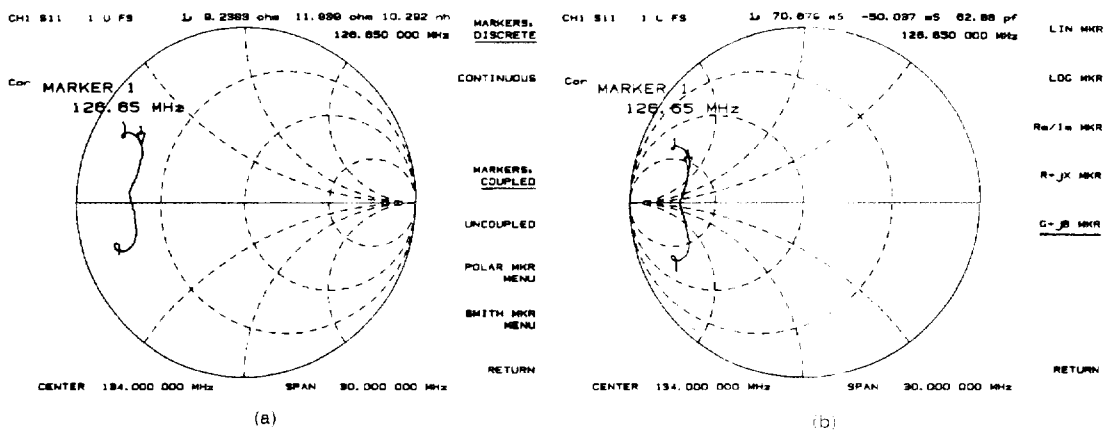

Figure 6-5. Standard and Inverse Smith Chart Formats

pg6176_c

Polar format

The *POLAR* softkey displays a polar format (refer to Figure 6-6). Each point on the polar format corresponds to a particular value of both magnitude and phase. Quantities are read vectorially: the magnitude at any point is determined by its displacement from the center (which has zero value), and the phase by the angle counterclockwise from the positive x-axis. Magnitude is scaled in a linear fashion, with the value of the outer circle usually set to a ratio value of 1. Since there is no frequency axis, frequency information is read from the markers.

The default marker readout for the polar format is in linear magnitude and phase. A log magnitude marker and a real/imaginary marker are available in the polar marker menu.

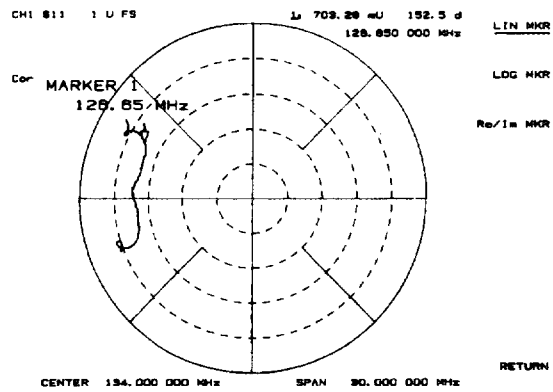

pg6177 c

Figure 6-6. Polar Format

Linear magnitude format

The *LIN MAG* softkey displays the linear magnitude format (refer to Figure 6-7). This is a Cartesian format used for unitless measurements such as reflection coefficient magnitude (ρ) or transmission coefficient magnitude (τ), and for linear measurement units. It is used for display of conversion parameters and time domain transform data.

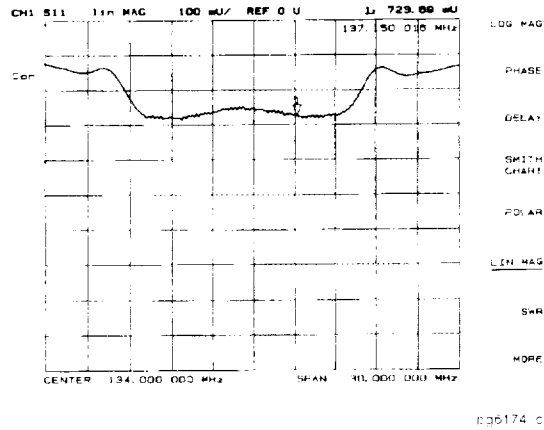

Figure 6-7. Linear Magnitude Format

SWR format

The *SWR* softkey reformats a reflection measurement into its equivalent SWR (standing wave ratio) value (refer to Figure 6-8). SWR is equivalent to $(1 + \rho)/(1 - \rho)$, where ρ is the reflection coefficient. Note that the results are valid only for reflection measurements. The results are not valid if the SWR format is used for measurements of S_{21} or S_{12} .

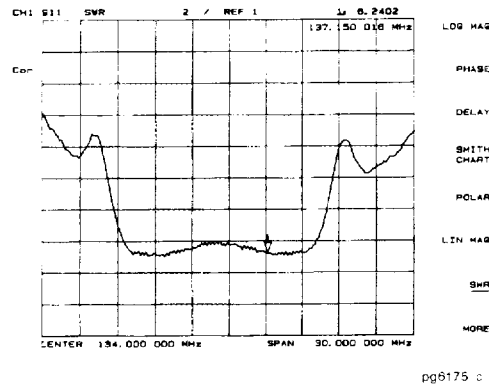

Figure 6-8. Typical SWR Display

Displaying and Saving Traces

Subtracting the memory trace from the displayed trace can be used for storing a measured vector error, for example, directivity. Then, you can later subtract it from the device measurement. The HP 8702D performs a vector subtraction on the complex data.

Perform ratio measurements between two channels

You can perform ratios of channel 1 and channel 2 in order to make harmonic measurements if your HP 8702D has Option 002 installed. For example, with the fundamental frequency displayed on channel 1 and the measured harmonic on channel 2, you can view the relative amplitude of the harmonic with respect to the fundamental.

To view both measurement channels

- 1 To see both channels simultaneously, press:
DISPLAY, DUAL CHAN ON
- 2 To view both channels on a single graticule, press:
MORE, SPLIT DISP OFF

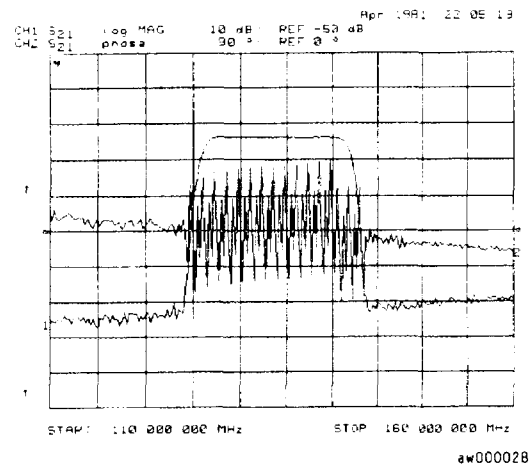

Figure 6-11. Viewing Both Channels with a Single Graticule

To save a data trace to a memory trace

- 1 To store the current active measurement data in the memory of the active channel, press:
DISPLAY, DATA →MEMORY

To view the measurement data and memory trace

- 1 Press DISPLAY, *MEMORY*.
This is the only memory display mode where you can change the smoothing and gating of the memory trace.
- 2 To view both the memory trace and the current measurement data trace, press: DISPLAY, *DATA and MEMORY*

To divide measurement data by the memory trace

- 1 You must have already stored a data trace to the active channel memory, as described in "To save a data trace to a memory trace" on page 6-23.
- 2 Press DISPLAY, *DATA/MEM* to divide the data by the memory.

To subtract the memory trace from the measurement data trace

- 1 You must have already stored a data trace to the active channel memory, as described in "To save a data trace to a memory trace" on page 6-23.
- 2 Press DISPLAY, *DATA-MEM* to subtract the memory from the measurement data.

To ratio measurements in channel 1 and 2

- 1 Press CHAN 1, MENU, *NUMBER of POINTS* and notice the number of points setting, shown on the HP 8702D display.
- 2 Press CHAN 2, MENU, *NUMBER of POINTS* and enter the same value that you observed for the channel 1 setting.
Both channels must have the same number of points.
- 3 Press DISPLAY, *DUAL CHAN ON, MORE, D2/D1 TO D2 ON* to ratio channels 1 and 2, and put the results in the channel 2 data array. This ratio is applied to the complex data.

Increasing Sweep Speed

You can increase the HP 8702D sweep speed by avoiding the use of some features that require computational time for implementation and updating, such as bandwidth marker tracking.

You can also increase the sweep speed by making adjustments to the measurement settings. The following suggestions for increasing sweep speed are general rules that you should experiment with:

- Decrease the frequency span
- Set the auto sweep time mode
- Widen the system bandwidth
- Reduce the averaging factor
- Reduce the number of measurement points
- Set the sweep type
- Use chop sweep mode

Reduce the frequency bands

The HP 8702D sweeps the frequency range in octave bands; switching from band to band takes time. Eliminate as many band switches as possible while maintaining measurement integrity.

Change the sweep mode and bandwidth

By reducing the averaging factor (number of sweeps) or switching off averaging, you can increase the HP 8702D's measurement speed. The time needed to compute averages can also slow the sweep time slightly, in narrow spans.

Auto sweep time mode is the default mode (the preset mode). This mode maintains the fastest sweep speed possible for the current measurement settings.

Table 6-2 shows the relative increase in sweep time as you decrease system bandwidth.

Table 6-2. Sweep Time Versus System Bandwidth

IF BW	Sweep Time (seconds) ^a	
	Full Span	Narrow Sweep
3000 Hz	0.44	0.18
1000 Hz	0.5	0.33
300 Hz	0.95	0.76
100 Hz	2.24	2.07
30 Hz	7.75	7.14
10 Hz	21.93	21.52

a. The listed sweep times correspond to the HP 8702D being set to a preset state for the full span, and 900 MHz to 1 GHz for the narrow span.

Vary the number of trace points

The sweep time does not change proportionally with the number of points, as indicated in Table 6-3.

Table 6-3. Sweep Time Versus Number of Points

Number of Points	Sweep Time (seconds) ^a			
	Full Span		Narrow Span	
	LIN	LIST/LOG	LIN	LIST
51	0.35	0.57	0.09	0.25
101	0.39	0.77	0.12	0.43
201	0.43	1.11	0.17	0.78
401	0.49	1.73	0.27	1.33
801	0.69	3.04	0.47	2.64
1601	1.09	5.7	0.87	5.3

a. The listed sweep times correspond to the HP 8702D being set to a preset state, with a 6 GHz span. A 3 GHz span would have faster sweep times.

View a single channel or use chop mode

Viewing a single channel will increase the measurement speed if the channels are in alternate, or uncoupled mode. If you must view both measurement channels simultaneously (with dual channel), use the chop sweep mode to make two measurements at the same time. For example, the HP 8702D can measure A/R and B/R simultaneously. You can activate the chop mode by pressing PRESET or by following the sequence below.

To decrease the frequency span

- 1** To see the band switch points (steps), press:
SYSTEM, SERVICE MENU, ANALOG BUS ON
MEAS, ANALOG IN Aux Input, 29, x1
- 2** Press *FORMAT, MORE, REAL, SCALE REF, AUTO SCALE.*
- 3** Enter the measurement frequency span of the device under test. Autoscale and modify the frequency span as appropriate.

To set the auto sweep time mode

- Press *MENU, SWEEP TIME, 0, x1,* to re-enter the auto mode.

To widen the system bandwidth

- 1** Press *AVG, IF BW.*
- 2** Set the IF bandwidth to change the sweep time.

To reduce the averaging factor

- 1 Press *AVG*, *AVERAGING FACTOR*.
- 2 Enter an averaging factor that is less than the value displayed on the HP 8702D screen and press *x1*.
- 3 If you want to switch off averaging, press:
AVG, *AVERAGING OFF*

To reduce the number of measurement points

- 1 Press *MENU*, *NUMBER of POINTS*.
- 2 Enter number of points that is less than the value displayed on the HP 8702D screen and press *x1*.

To set the sweep type

- 1 Press *MENU*, *SWEEP TYPE MENU*.
- 2 Select the sweep type:
 - Select *LIN FREQ* for the fastest sweep for a given number of fixed points. In addition to the numbers listed in Table 6-3, the linear frequency format also has point settings of 3, 11, and 26.
 - Select *LOG FREQ* for the fastest sweep when the frequency points of interest are in the lower part of the frequency span selected.
 - Select *LIST FREQ* for the fastest sweep when specific frequency points are of interest.

To view a single measurement channel

- 1 Press DISPLAY, *DUAL CHAN OFF*.
- 2 Press CHAN 1 and CHAN 2 to alternately view the two measurement channels.

To activate chop sweep mode

- Press CAL, *MORE*, *CHOP A and B*.

Increasing Dynamic Range

Dynamic range is the difference between the HP 8702D's maximum allowable input level and minimum measurable power. For a measurement to be valid, input signals must be within these boundaries. The dynamic range is affected by these factors:

- test port input power
- reduce bandwidth to lower noise floor
- apply averaging to remove effects of random noise

You can increase the HP 8702D's source output power so that the test device output power is at the top of the measurement range of the HP 8702D test port (+10 dBm).

Each tenfold reduction in IF (receiver) bandwidth lowers the noise floor by 10 dB. For example, changing the IF bandwidth from 3 kHz to 300 Hz, you will lower the noise floor by about 10 dB.

To increase the test port input power

- 1 Press MENU, *POWER* and enter the new source power level, followed by x1.

CAUTION

TEST PORT INPUT DAMAGE LEVEL: +26 dBm

To reduce the bandwidth

- 1 Press *AVG, IF BW*.
- 2 Enter the bandwidth value that you want, followed by *x1*.

To apply averaging

- 1 Press *AVG, AVERAGING FACTOR*.
- 2 Enter a value followed by *x1*.
- 3 Press *AVERAGING ON*.

Reducing Trace Noise

You can use two HP 8702D functions to help reduce the effect of noise on the data trace:

- activate measurement averaging
- reduce system bandwidth

The noise is reduced with each new sweep as the effective averaging factor increments.

By reducing the system bandwidth, you reduce the noise that is measured during the sweep. While averaging requires multiple sweeps to reduce noise, narrowing the system bandwidth reduces the noise on each sweep. Narrower system bandwidths cause longer sweep times. When in auto sweep time mode, the HP 8702D uses the fastest sweep time possible for any selected system bandwidth. Auto sweep time mode is the default (preset) HP 8702D setting.

The AVG key is used to access three different noise reduction techniques: sweep-to-sweep averaging, display smoothing, and variable IF bandwidth. Any or all of these can be used simultaneously. Averaging and smoothing can be set independently for each channel, and the IF bandwidth can be set independently if the stimulus is uncoupled.

Averaging

Averaging computes each data point based on an exponential average of consecutive sweeps weighted by a user-specified averaging factor. Each new sweep is averaged into the trace until the total number of sweeps is equal to the averaging factor, for a fully averaged trace. Each point on the trace is the vector sum of the current trace data and the data from the previous sweep. A high averaging factor gives the best signal-to-noise ratio, but slows the trace update time. Doubling the averaging factor reduces the noise by 3 dB. Averaging is used for ratioed measurements. If it is attempted for a single-input measurement (for example, A or B), the message CAUTION: AVERAGING INVALID ON NON-RATIO MEASURE is displayed. Figure 6-12 illustrates the effect of averaging on a log magnitude format trace.

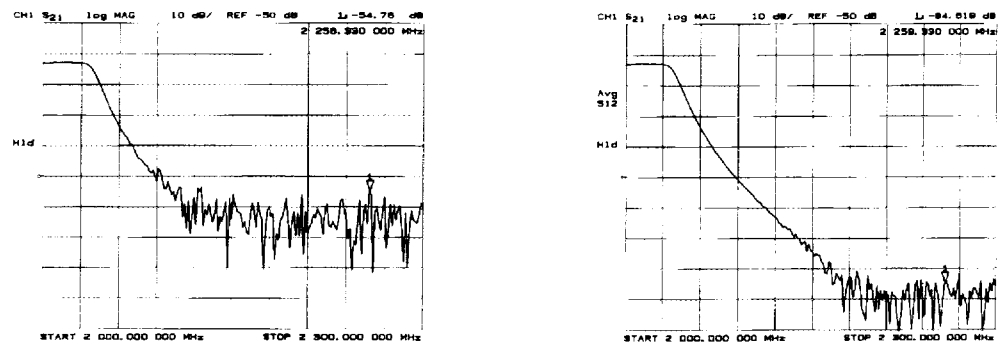

pg6171 c

Figure 6-12. Effect of Averaging on a Trace

NOTE

If you switch power ranges with averaging on, the average will restart.

Reducing Trace Noise**Smoothing**

Smoothing (similar to video filtering) averages the formatted active channel data over a portion of the displayed trace. Smoothing computes each displayed data point based on one sweep only, using a moving average of several adjacent data points for the current sweep. The smoothing aperture is a percent of the swept stimulus span, up to a maximum of 20%.

Rather than lowering the noise floor, smoothing finds the mid-value of the data. Use it to reduce relatively small peak-to-peak noise values on broadband measured data. Use a sufficiently high number of display points to avoid misleading results. Do not use smoothing for measurements of high resonance devices or other devices with wide trace variations, as it will introduce errors into the measurement.

Smoothing is used with Cartesian and polar display formats. It is also the primary way to control the group delay aperture, given a fixed frequency span (refer to "Group delay format" on page 6-15). In polar display format, large phase shifts over the smoothing aperture will cause shifts in amplitude, since a vector average is being computed. Figure 6-13 illustrates the effect of smoothing on a log magnitude format trace.

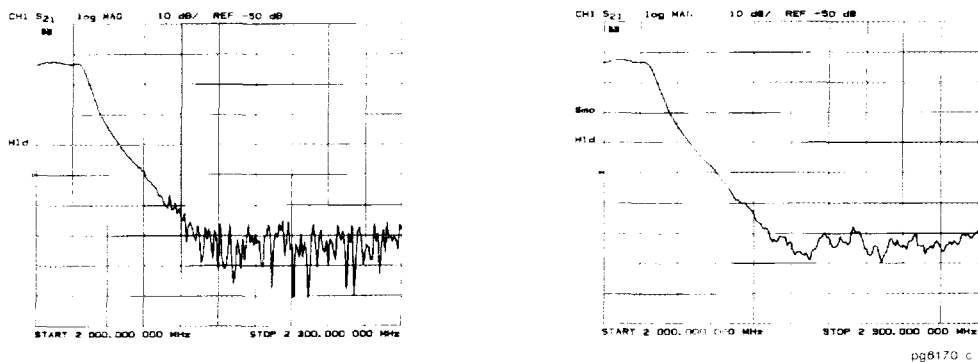

Figure 6-13. Effect of Smoothing on a Trace

IF bandwidth reduction

IF bandwidth reduction lowers the noise floor by digitally reducing the receiver input bandwidth. It works in all ratio and non-ratio modes. It has an advantage over averaging as it reliably filters out unwanted responses such as spurs, odd harmonics, higher frequency spectral noise, and line-related noise. Sweep-to-sweep averaging, however, is better at filtering out very low frequency noise. A tenfold reduction in IF bandwidth lowers the measurement noise floor by about 10 dB. Bandwidths less than 300 Hz provide better harmonic rejection than higher bandwidths.

Another difference between sweep-to-sweep averaging and variable IF bandwidth is the sweep time. Averaging displays the first complete trace faster but takes several sweeps to reach a fully averaged trace. IF bandwidth reduction lowers the noise floor in one sweep, but the sweep time may be slower. Figure 6-14 illustrates the difference in noise floor between a trace measured with a 3000 Hz IF bandwidth and with a 10 Hz IF bandwidth.

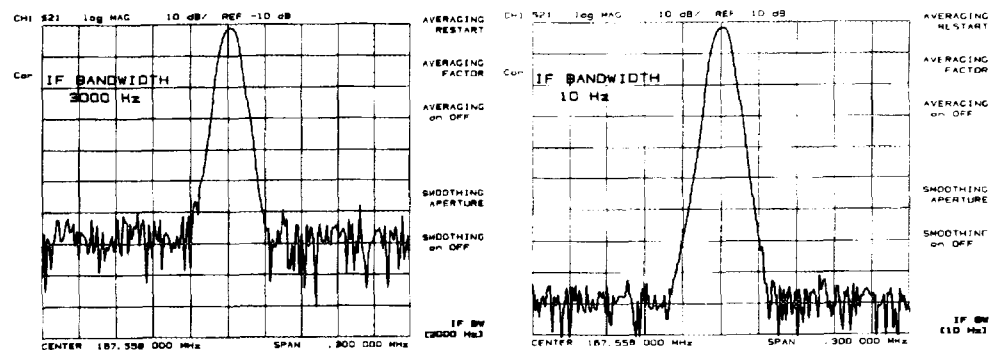

Figure 6-14. IF Bandwidth Reduction

pg6188 c

HINTS

Another capability that can be used for effective noise reduction is the marker statistics function, which computes the average value of part or all of the formatted trace.

Another way of increasing dynamic range is to increase the input power to the test device using an HP 8347A amplifier.

To activate averaging

- 1 Press *AVG, AVERAGING FACTOR*.
 - 2 Enter a value followed by *x1*.
 - 3 Press *AVERAGING ON*.
-

To change system bandwidth

- 1 Press *AVG, IF BW*.
- 2 Enter the IF bandwidth value that you want, followed by *x1*.

Reducing Receiver Crosstalk

Receiver crosstalk can be reduced by performing a response and isolation measurement calibration and setting the sweep to the alternate mode. Alternate sweep is intended for measuring wide dynamic range devices, such as high pass and bandpass filters. This sweep mode removes a type of leakage term through the device under test, from one channel to another.

To reduce crosstalk

- Press *CAL*, *MORE*, *ALTERNATE A* and *B*.

Knowing the Instrument Modes

This section describes the major instrument modes of the analyzer:

- component analyzer mode
- external source mode
- tuned receiver mode
- frequency offset operation
- harmonic mode operation (Option 002)

All of the features described in this section are accessible under the SYSTEM key.

Component analyzer mode

This is the standard mode of operation for the analyzer, and is active after you press PRESET or switch on the AC power.

Pressing SYSTEM, *INSTRUMENT MODE*, *COMPONENT ANALYZER* returns the analyzer to the “normal” component analyzer operating mode.

This mode uses the analyzer's internal source.

External source mode

This mode allows the analyzer to phase lock to an external CW signal. External source mode is best used for unknown signals, or for signals that drift. If a synthesized external source is used, the tuned receiver mode is recommended because it is faster.

Primary applications

External source mode is useful in several applications:

- when your test device is a mixer or other frequency translation device
- in automated test applications where a source is already connected to the system, and you do not want to switch between the system source and the analyzer's internal source.

Typical test setup

Figure 6-15 shows a typical test setup using the external source mode. The same test setup is applicable for either manual or automatic external source mode operation.

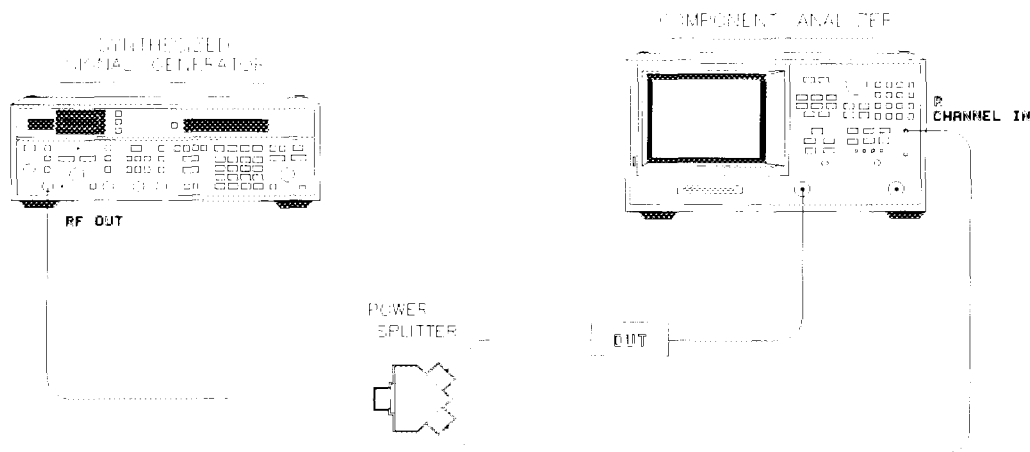

Figure 6-15. Typical Setup for the External Source Mode

External source mode in-depth description

You may use the external source in automatic or manual mode. External source mode phase locks the analyzer to an external CW signal.

NOTE

The external source mode works only in CW time sweep.

External source auto

If you press SYSTEM, INSTRUMENT MODE, EXT SOURCE AUTO the analyzer turns on the external source auto mode. You should observe the following points when using this operation mode:

- The auto mode has a wider capture range than the manual mode.
- The manual mode is faster than the auto mode.
- The auto mode searches for the incoming CW signal.
- The capture range is typically 10% of the selected CW frequency.
- This feature works only in CW time sweep type.
- The incoming signal should not have large spurs or sidebands, as the analyzer may phase lock on a spur or not phase lock at all.

The frequency the instrument has locked onto is shown on the analyzer, and is also available via HP-IB.

External source manual

If you press SYSTEM, INSTRUMENT MODE, EXT SOURCE MANUAL the analyzer activates the external source manual mode. You should observe the following points when using this operation mode:

- The manual mode has a smaller capture range than the auto mode.
- The manual mode is much faster than auto mode.
- This feature works only in CW time sweep type.
- The incoming signal should not have large spurs or sidebands, as the analyzer may phase lock on a spur or not phase lock at all.
- The frequency of the incoming signal should be within -0.5 to +5.0 MHz of the selected frequency or the analyzer will not be able to phase lock to it.

CW frequency range in external source mode

300 kHz to 3 GHz (6 GHz for Option 006)

Compatible sweep types

The external source mode will only function in CW time sweep. If the instrument is in any other sweep type when external source is activated, the warning message CHANGED TO CW TIME MODE will appear on the display.

External source requirements

The external source mode has spectral purity and power input requirements, which are described in the *HP 8702D Reference* manual.

Input Channel: R

Capture range

In either automatic or manual mode, you can enter the frequency of the external CW signal using the *CW FREQ* softkey (located under the Stimulus MENU key). The actual signal must be within a certain frequency capture range as shown in Table 6-4.

Table 6-4. External Source Capture Ranges

Mode	CW Frequency	Capture Range
Automatic	≤ 50 MHz	± 5 MHz of nominal CW frequency
	> 50 MHz	$\pm 10\%$ of nominal CW frequency
Manual	All	-0.5 to $+5$ MHz of nominal CW frequency

If the incoming signal is not within the capture range, the analyzer will not phase lock correctly.

Locking onto a signal with a frequency modulation component

Although the analyzer may phase-lock onto a signal that has FM, it may not accurately show the signal's amplitude. The accuracy of such measurements depends greatly on the IF bandwidth you choose. Use the widest IF bandwidth available (3 kHz) if this problem occurs.

Tuned receiver mode

If you press **SYSTEM**, **INSTRUMENT MODE**, **TUNED RECEIVER**, the analyzer receiver operates independently of any signal source.

The following features and limitations apply to the tuned receiver mode:

- It is a fully synthesized receiver; it does not phase-lock to any source.
- It functions in all sweep types.
- It requires a synthesized CW source whose timebase is input to the analyzer's external frequency reference.
- It is much faster than external source mode.

Primary applications

The tuned receiver mode is useful for these applications:

- Automated test applications where an external synthesized source is available.
- In applications where speed is important.

Typical test setup

Figure 6-16 shows a typical test setup using tuned receiver mode in a CW measurement. You can input the signal to either **PORT 1** or **PORT 2**; but port 2 is recommended.



Figure 6-16. Typical Test Setup for Tuned Receiver Mode

The tuned receiver mode is typically used in CW applications. An example of non-CW operation is as follows:

- third order intermodulation measurement
- list mode
- manual trigger
- external synthesized source

Refer to the third order intermodulation measurement description in Product Note 8753-1, *Amplifier Measurements with the HP 8753*, HP part number 5956-4361.

Tuned receiver mode in-depth description

Frequency Range. 30 kHz to 3 GHz (6 GHz for Option 006)

Compatible Sweep Types. All sweep types may be used.

External Source Requirements. The tuned receiver mode has the following input requirements: port 1, port 2, or input R.

Input power range specifications are provided in the *HP 8702D Reference manual*.

Frequency offset operation

If you press **SYSTEM**, **INSTRUMENT MODE**, **FREQ OFFSET MENU**, the analyzer allows phase-locked operation with a frequency offset between the internal source and receiver. This feature is used in swept RF mixer measurements and has an upper frequency limit of 3 GHz (or 6 GHz for Option 006).

This feature allows you to set the RF source to a fixed offset frequency above or below the receiver (as required in a mixer test, using a swept RF/IF and fixed LO). Then you can input a signal to a device over one frequency range and view its response over a different frequency range. The maximum delay between the RF source and the R input is 0.3 microseconds. The analyzer will show a signal that is a composite of the desired RF signal, image response, and spurious signals.

You can use the frequency offset in any sweep type in component analyzer mode. The two user-defined variables in this mode are receiver frequency and offset frequency (LO). The analyzer automatically sets the source frequency and equals $IF + LO$ or $IF - LO$.

Mixer measurements and frequency offset mode applications are explained in Application Note 8753-2, *RF Component Measurements Mixer Measurements using the HP 8753B Network Analyzer*, HP part number 5956-4362. This application note was written for the HP 8753B but also applies to the HP 8702D. Also see Product Note 8753-2A, HP part number 5952-2771.

Primary applications

Frequency offset mode is useful for the following types of measurements on frequency-translating devices:

- conversion loss
- conversion compression
- amplitude and phase tracking

Typical test setup Figure 6-17 shows a typical test setup using frequency offset mode. Instructions are provided in Chapter 4, “Measuring Electrical Devices”. The attenuators shown reduce mismatch uncertainties. The low pass filter keeps unwanted mixing products out of the HP 8702D sampler.

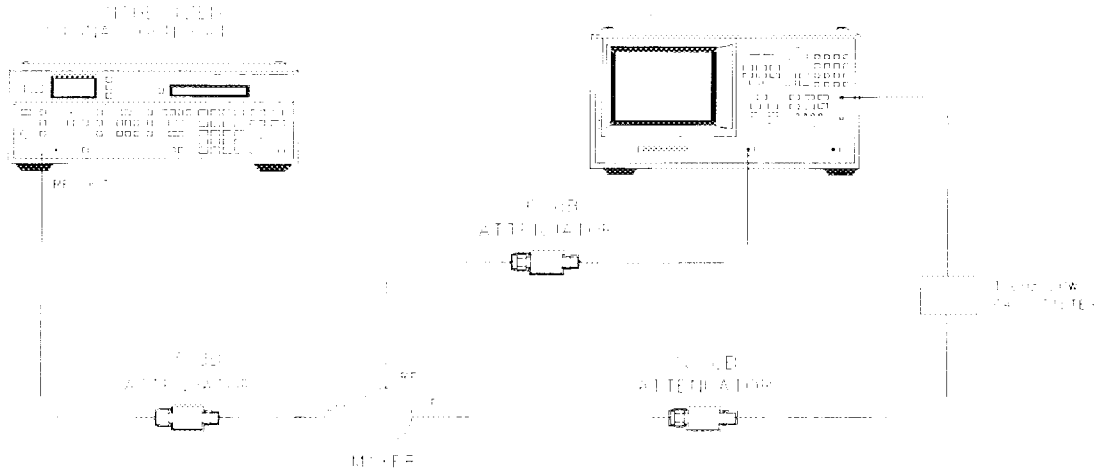

Fig. 6-17a

Figure 6-17. Typical Test Setup for a Frequency Offset Measurement

**Frequency offset
in-depth
description**

The source and receiver operate at two different frequencies in frequency offset operation. The difference between the source and receiver frequencies is the LO frequency that you specify.

The two user-defined variables in frequency offset are the receiver frequency, and the offset (LO) frequency. The source frequency is automatically set by the instrument and equals receiver frequency $IF + LO$ or $IF - LO$.

The receiver frequency

You can choose a CW value or start and stop values for the receiver frequency. The stimulus values only affect the receiver which then appear on the analyzer display.

The offset frequency (LO)

This frequency value is the difference between the source and receiver frequencies.

NOTE

The analyzer's source locks to the receiver \pm the LO frequency, regardless of the offset value you selected.

Once the source is phase-locked and sweeping, the analyzer's source frequency is not known precisely. As the LO frequency changes, the source tracks it to maintain the receiver start/stop or CW frequency that you requested.

Frequency hierarchy

The source frequency can be greater than or less than the LO frequency. That is, the analyzer can measure either the lower or upper of the two IF mixing products when it is in the frequency offset mode.

Frequency ranges

Receiver frequency range = 30 kHz to 3 GHz (optionally 6 GHz).

Minimum recommended offset (LO) frequency = 16 MHz.

Compatible instrument modes and sweep types

Frequency offset is compatible with all sweep types in the component analyzer mode.

Receiver and source requirements

Refer to the *HP 8702D Reference* manual for specifications and measurement uncertainties.

IF Input: R always; and port 1 or port 2 for a ratio measurement.

Display annotations

The analyzer shows the annotation *ofs* when the frequency offset mode is on. The annotation *of?* indicates that the source frequency is approximately 10 MHz away from the sum of the IF and LO frequencies that you requested. This is most likely caused by the LO frequency being outside the -1 to $+5$ MHz accuracy requirement.

Error message

If you connect your test device before you switch on the frequency offset function, the error message PHASE LOCK CAL FAILED appears on the screen. This is normal, and will disappear when you press the *FREQ OFFS OFF* softkey.

Spurious signal passband frequencies

Unwanted mixing products (or spurious LO signals) at specific frequencies can cause measurement inaccuracy, because of the characteristics of a sampler. These specific frequencies can be calculated. You can reduce unwanted mixing products going to the sampler by inserting a low pass filter at your test device's IF output.

Harmonic operation (Option 002 only)

The harmonic measurement mode allows you to measure the second or third harmonic as the analyzer's source sweeps fundamental frequencies above 16 MHz. The analyzer can make harmonic measurements in any sweep type.

Typical test setup

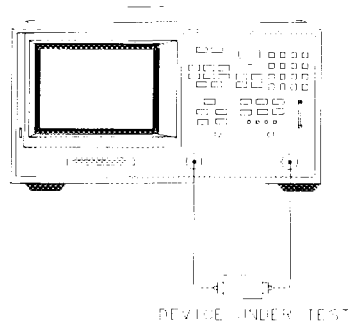

Figure 6-18. Typical Harmonic Mode Test Setup

Single-channel operation

You can view the second or third harmonic alone by using only one of the analyzer's two channels.

Dual-channel operation

To make the following types of measurements, uncouple channels 1 and 2, and switch on dual channel.

- The analyzer measures the fundamental on one channel while measuring the second or third harmonic on the other channel.
- The analyzer measures the second harmonic on one channel while measuring the third harmonic on the other channel.
- Using the *COUPLE PWR ON* feature, the analyzer measures the fundamental on channel 1 while measuring the second or third harmonic in dBc on channel 2.
- Using the *COUPLE PWR ON* feature, the analyzer couples power between channels 1 and 2. This is useful when you are using the D2/D1 to D2 feature; because you can change fundamental power and see the resultant change in the harmonic power.

The analyzer shows the fundamental frequency value on the display. However, a marker in the active entry area shows the harmonic frequency in addition to the fundamental. If you use the harmonic mode, the annotation H=2 or H=3 appears on the left-hand side of the display. The measured harmonic cannot exceed the frequency limitations of the component analyzer's receiver.

Coupling power between channels 1 and 2

COUPLE PWR ON is intended to be used with the *D2/D1 to D2 OFF* softkey. You can use the D2/D1 to D2 function in harmonic measurements, where the analyzer shows the fundamental on channel 1 and the harmonic on channel 2. D2/D1 to D2 ratios the two, showing the fundamental and the relative power of the measured harmonic in dBc. You must uncouple channels 1 and 2 for this measurement, using the *COUPLED CHAN OFF* softkey, set to *OFF* to allow alternating sweeps.

After uncoupling channels 1 and 2, you may want to change the fundamental power and see the resultant change in relative harmonic power (in dBc). *COUPLE PWR ON* allows you to change the power of both channels simultaneously, even though they are uncoupled in all other respects.

Frequency range

The frequency range is determined by the upper frequency range of the instrument or system (3 or 6 GHz) and by the harmonic being displayed. The 6 GHz operation requires an HP 8702D Option 006. Table 6-5 shows the highest fundamental frequency for maximum frequency and harmonic mode.

Table 6-5. Maximum Fundamental Frequency using Harmonic Mode

Harmonic Measured	Maximum Fundamental Frequency	
	HP 8702D	HP 8702D Option 006
2nd Harmonic	1.5 GHz	3 GHz
3rd Harmonic	1.0 GHz	2.0 GHz

Accuracy and input power

Refer to the *HP 8702D Reference* manual for information on specifications and measurement uncertainties. The maximum recommended input power and maximum recommended source power are related specifications.

Using power levels greater than the recommended values, you may cause undesired harmonics in the source and receiver. The recommended power levels ensure that these harmonics are less than 45 dBc. Use test port power to limit the input power to your test device.

Measuring with Markers

Measuring with Markers

The HP 8702D provides markers for measuring absolute and relative values on traces. You can position up to five markers at any position on any trace. Delta markers allow you to measure the separation between measurement points. You can even use markers to locate peak values and change the displayed measurement range.

Special *fixed* markers are available which can be placed anywhere on the display—they don't have to be placed on a trace.

Markers have a stimulus value (the x-axis value in a Cartesian format) and a response value (the y-axis value in a Cartesian format). In a polar or Smith chart format, the second part of a complex data pair is also provided as an auxiliary response value. When you switch on a marker, and no other function is active, the HP 8702D shows the marker stimulus value in the active entry area.

- If you activate both data and memory traces, the marker values apply to the data trace.
- If you activate only the memory trace, the marker values apply to the memory trace.
- If you activate a memory math function (data/memory or data-memory), the marker values apply to the trace resulting from the memory math function.

What you'll find in this chapter

General Information	7-4
Activating Markers	7-9
Setting the Measurement Range	7-12
Making Relative Measurements	7-20
Searching with Markers	7-24
Making Statistical Measurements	7-28
Using Markers with Other Display Formats	7-30
Making Other Measurements	7-34

General Information

The MARKER key displays a movable active marker on the screen and provides access to a series of menus to control up to five display markers for each channel. Markers are used to obtain numerical readings of measured values. They also provide capabilities for reducing measurement time by changing stimulus parameters, searching the trace for specific values, or statistically analyzing part or all of the trace.

Markers have a stimulus value (the x-axis value in a Cartesian format) and a response value (the y-axis value in a Cartesian format). In a polar or Smith chart format, the second part of a complex data pair is also provided as an auxiliary response value. When a marker is activated and no other function is active, its stimulus value is displayed in the active entry area and can be controlled with the knob, the step keys, or the numeric keypad. The active marker can be moved to any point on the trace, and its response and stimulus values are displayed at the top right corner of the graticule for each displayed channel, in units appropriate to the display format. The displayed marker response values are valid even when the measured data is above or below the range displayed on the graticule.

Marker values are normally continuous: that is, they are interpolated between measured points. Or, they can be set to read only discrete measured points. The markers for the two channels normally have the same stimulus values, or they can be uncoupled so that each channel has independent markers, regardless of whether stimulus values are coupled or dual channel display is on.

If both data and memory are displayed, the marker values apply to the data trace. If only memory is displayed, the marker values apply to the memory trace. In a memory math display (data/memory or data + memory), the marker values apply to the trace resulting from the memory math function.

With the use of a reference marker, a delta marker mode is available that displays both the stimulus and response values of the active marker relative to the reference. Any of the five markers or a fixed point can be designated as the delta reference marker. If the delta reference is one of the five markers, its stimulus value can be controlled by the user and its response value is the value

of the trace at that stimulus value. If the delta reference is a fixed marker, both its stimulus value and its response value can be set arbitrarily anywhere in the display area (not necessarily on the trace).

Markers can be used to search for the trace maximum or minimum point or any other point on the trace. The five markers can be used together to search for specified bandwidth cutoff points and calculate the bandwidth and Q values. Statistical analysis uses markers to provide a readout of the mean, standard deviation, and peak-to-peak values of all or part of the trace.

Basic marker operations are available in the menus accessed from the MARKER key. The marker search and statistical functions, together with the capability for quickly changing stimulus parameters with markers, are provided in the menus accessed from the MARKER FCTN key.

Marker menu

The marker menu is used to turn the display markers on or off, to designate the active marker, and to gain access to the marker delta mode and other marker modes and formats.

Delta marker menu

The delta reference is shown on the display as a small triangle, Δ , which is smaller than the inactive marker triangles. If one of the markers is the reference, the triangle appears next to the marker number on the trace.

The marker values displayed in this mode are the stimulus and response values of the active marker minus the reference marker. If the active marker is also designated as the reference marker, the marker values are zero.

Marker offset menu

This menu is used to set the position of a fixed reference marker, indicated on the display by a small triangle, Δ . Both the stimulus value and the response value of the fixed marker can be set arbitrarily anywhere in the display area, and need not be on the trace. The units are determined by the display format, the sweep type, and the marker type.

General Information

There are two ways to turn on the fixed marker. One way is with the Δ REF= Δ FIXED MKR softkey in the delta marker menu. The other is with the MKR ZERO function in the marker menu, which puts a fixed reference marker at the present active marker position and makes the marker stimulus and response values at that position equal to zero.

The softkeys in this menu make the values of the fixed marker the active function. The marker readings in the top right corner of the graticule are the stimulus and response values of the active marker minus the fixed reference marker. Also displayed in the top right corner is the notation Δ REF= Δ .

The stimulus value, response value, and auxiliary response value (the second part of a complex data pair) can be individually examined and changed. This allows active marker readings that are relative in amplitude yet absolute in frequency, or any combination of relative/absolute readings. Following a MKR ZERO operation, this menu can be used to reset any of the fixed marker values to absolute zero for absolute readings of the subsequent active marker values.

If the format is changed while a fixed marker is on, the fixed marker values become invalid. For example, if the value offset is set to 10 dB with a log magnitude format, and the format is then changed to phase, the value offset becomes 10 degrees. However, in polar and Smith chart formats, the specified values remain consistent between different marker types for those formats. Therefore, an R+jX marker set on a Smith chart format will retain the equivalent values if it is changed to any of the other Smith chart markers.

Marker mode menu

This menu, accessed from the MARKER key, provides different marker modes and makes available two additional menus of special markers for use with Smith chart or polar formats.

Polar marker menu

This menu is accessed from the MARKER FCTN key and is used only with a polar display format, selectable using the FORMAT key. In a polar format, the magnitude at the center of the circle is zero and the outer circle is the full scale value set in the scale reference menu. Phase is measured as the angle counter-clockwise from 0° at the positive x-axis. The analyzer automatically calculates

different mathematical forms of the marker magnitude and phase values, selected using the softkeys in this menu. Marker frequency is displayed, in addition to other values, regardless of the selection of marker type.

Smith marker menu

This menu is accessed from the MARKER FCTN key and is used only with a Smith chart format, selected from the FORMAT menu. The analyzer automatically calculates different mathematical forms of the marker magnitude and phase values, selected using the softkeys in this menu. Marker frequency is displayed in addition to other values for all marker types.

Marker mode menu

This menu, accessed from the MARKER FCTN key, provides softkeys that use markers to quickly modify certain measurement parameters without going through the usual key sequence. In addition, it provides access to two additional menus used for searching the trace and for statistical analysis.

The *MARKER* → functions change certain stimulus and response parameters to make them equal to the current active marker value. Use the knob or the numeric keypad to move the marker to the desired position on the trace, and press the appropriate softkey to set the specified parameter to that trace value. When the values have been changed, the marker can again be moved within the range of the new parameters.

Marker search menu

This menu is used to search the trace for a specific amplitude-related point, and place the marker on that point. The capability of searching for a specified bandwidth is also provided. Tracking is available for a continuous sweep-to-sweep search. If there is no occurrence of a specified value or bandwidth, the message TARGET VALUE NOT FOUND is displayed.

Target menu

The target menu lets you place the marker at a specified target response value on the trace, and provides search right and search left options. If there is no occurrence of the specified value, the message TARGET VALUE NOT FOUND is displayed.

Activating Markers

The active marker appears on the HP 8702D display as ∇ . Any displayed inactive markers are represented on the HP 8702D display as Δ . The active marker stimulus value is displayed in the active entry area. You can modify the stimulus value of the active marker, using the front panel knob or numeric keypad. All of the marker response and stimulus values are displayed in the upper right corner of the display.

The HP 8702D can either place markers on discrete measured points, or move the markers continuously along a trace by interpolating the data value between measured points.

At a preset state, the markers have the same stimulus values on each channel, but they can be uncoupled so that each channel has independent markers.

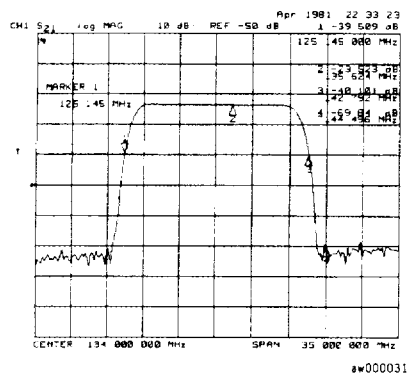

Figure 7-1. Example of Active and Inactive Markers

Activating Markers

To display a marker

- 1 Press **MARKER**, *MARKER 1* to switch on marker 1 and make it the active marker.
- 2 To switch on the corresponding marker and make it the active marker, press: *MARKER 2*, *MARKER 3*, *MARKER 4*, or *MARKER 5*.

All of the markers, other than the active marker, become inactive and are represented on the HP 8702D display as Δ .

To turn off all markers

- 1 Press *all OFF*.

To select continuous or discrete markers

- 1 Press **MARKER FCTN**, *MARKER MODE MENU*, and select one of the following choices:
 - Choose *MARKERS: DISCRETE* if you want the HP 8702D to place markers only on measured trace points determined by the stimulus settings. This may be the best mode to use with automated testing, using a computer or test sequencing.
 - Choose *MARKERS: CONTINUOUS* if you want the HP 8702D to place markers at any point on the trace, by interpolating between measured points. This default mode allows you to conveniently get round numbers for the stimulus value.

To uncouple display markers

- 1 Press **MARKER FCTN**, **MARKER MODE MENU** and select from the following keys:
 - Choose **MARKERS: COUPLED** if you want the HP 8702D to couple the marker stimulus values for the two display channels.
 - Choose **MARKERS: UNCOUPLED** if you want the HP 8702D to uncouple the marker stimulus values for the two display channels. This allows you to control the marker stimulus values independently for each channel.

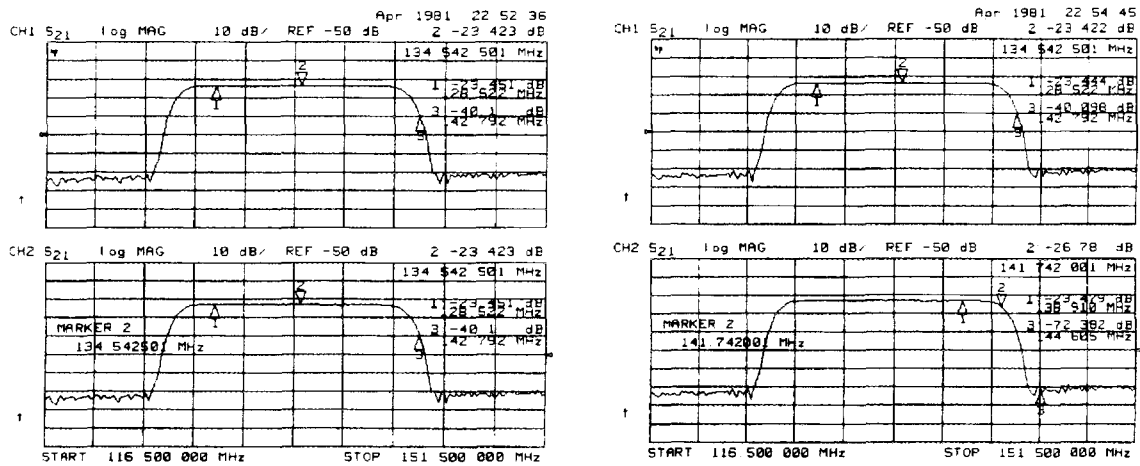

pg6235

Figure 7-2. Example of Coupled and Uncoupled Markers

Setting the Measurement Range

The HP 8702D allows you to set measurement parameters with the markers, without going through the usual key sequence. You can change certain stimulus and response parameters to make them equal to the current active marker value.

You can span equal to the spacing between two markers. If you set the center frequency before you set the frequency span, you will have a better view of the area of interest.

You can use markers to measure electrical length or deviation from linear phase. This is accomplished by adding or subtracting electrical delay. This effectively flattens the phase trace around the active marker. This feature adds phase delay to a variation in phase versus frequency, therefore it is only applicable for ratioed inputs. Additional electrical delay adjustments are required on devices without constant group delay over the measured frequency span.

To set the start and stop frequency

- 1 Press **MARKER FCTN** and turn the front panel knob to position the marker at the value that you want for the start frequency.
- 2 Press **MARKER → START** to change the start frequency value to the value of the active marker.

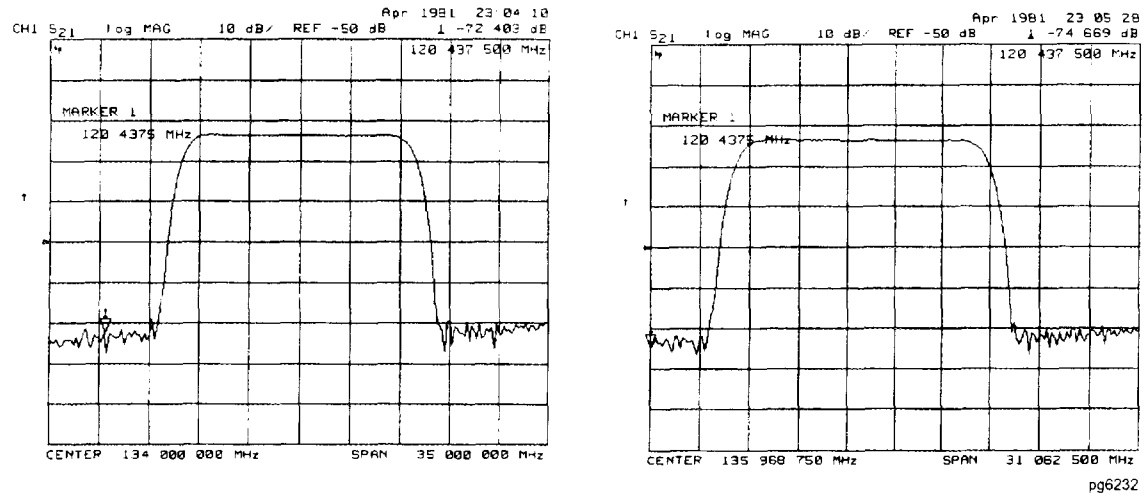
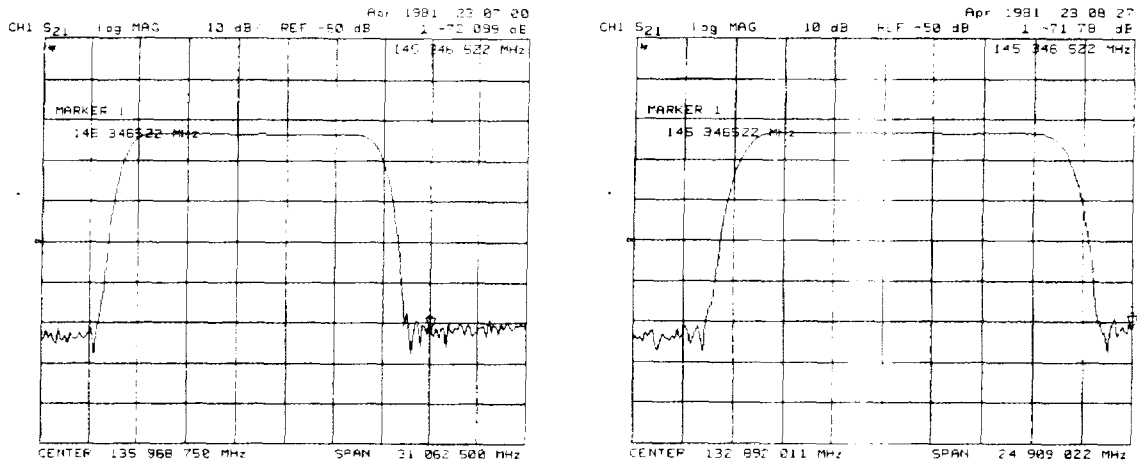

Figure 7-3. Example of Setting the Start Frequency Using a Marker

Measuring with Markers
Setting the Measurement Range

- 3 Turn the front panel knob to position the marker at the value that you want for the stop frequency.
- 4 Press *MARKER* → *STOP* to change the stop frequency value to the value of the active marker.



pg6233

Figure 7-4. Example of Setting the Stop Frequency Using a Marker

To set the center frequency

- 1 Press **MARKER FCTN** and turn the front panel knob to position the marker at the value that you want for the center frequency.
- 2 Press **MARKER** → **CENTER** to change the center frequency value to the value of the active marker.

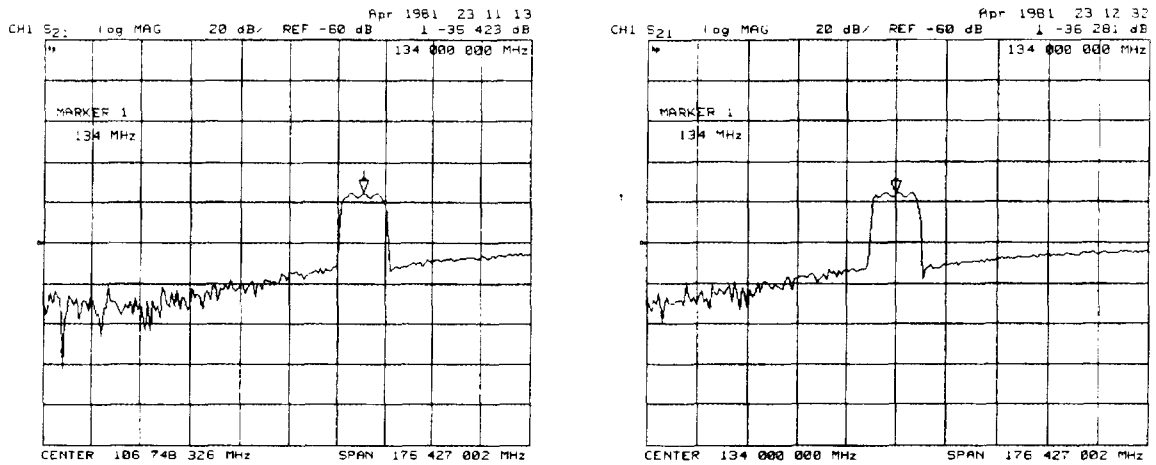

pg623

Figure 7-5. Example of Setting the Center Frequency Using a Marker

To set the frequency span

- 1 Press **MARKER**, Δ **MODE MENU**, Δ **REF = 1**.
- 2 Turn the front panel knob to position the marker where you want the frequency span to start.
- 3 Press Δ **REF = 2**. Position the marker where you want the span to end.
Iterate between marker 1 and marker 2 by pressing **MARKER 1** and **MARKER 2**, respectively, and turning the front panel knob to position the markers around the center frequency.
- 4 Press **MARKER FCTN**, **MARKER** \rightarrow **SPAN** to change the frequency span to the range between marker 1 and marker 2.

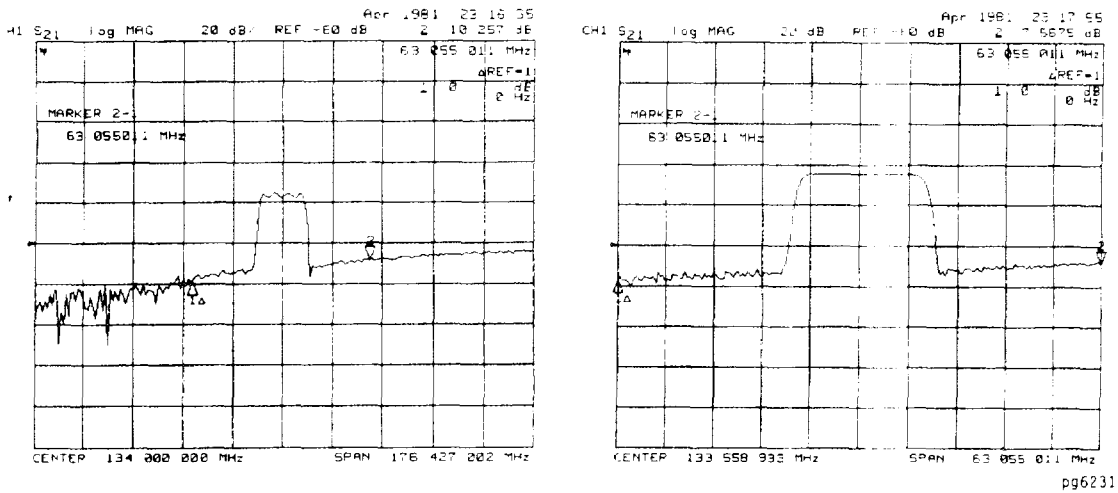
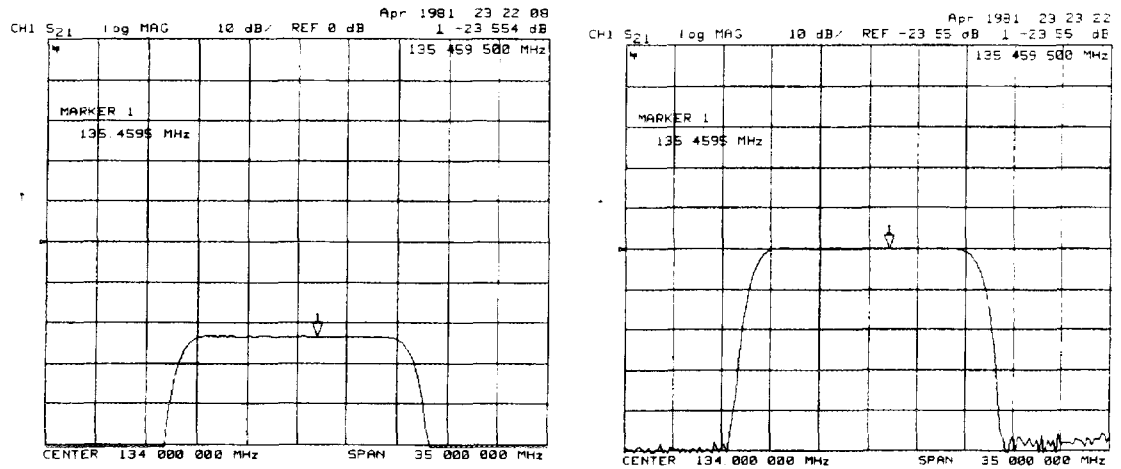

Figure 7-6. Example of Setting the Frequency Span Using Markers

To set the display reference

- 1 Press **MARKER FCTN**, and turn the front panel knob to position the marker at the value that you want for the display reference value.
- 2 Press **MARKER →REFERENCE**.



pg6228

Figure 7-7. Example of Setting the Reference Value Using a Marker

To set the CW frequency

- 1 To place a marker at the desired CW frequency:

Press **MARKER** and either turn the front panel knob or enter the value using the front-panel keys.

- 2 Press **SEQ**, *SPECIAL FUNCTIONS*, **MARKER** → *CW*.

You can use this function to set the marker to a gain peak in an amplifier. After pressing **MARKER** → *CW*, activate a *CW* frequency power sweep to look at the gain compression with increasing input power.

To set electrical delay

- 1 Press **FORMAT, PHASE**.
- 2 Press **MARKER FCTN, MARKER** → **DELAY** to add or subtract enough line length to the receiver input to compensate for the phase slope at the active marker position.

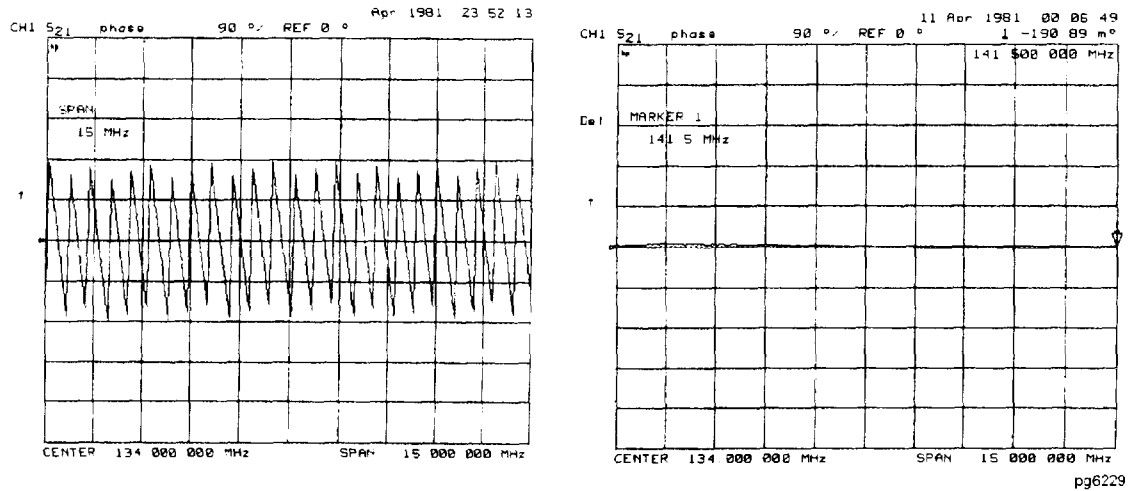

Figure 7-8. Example of Setting the Electrical Delay Using a Marker

Making Relative Measurements

Delta markers measure the position of the active marker relative to a reference marker. You turn on delta markers by assigning one of the five standard markers as the delta reference. Then, you select another marker measurement. The reference marker can be a special *fixed* marker which is located anywhere on the display and off the trace. Fixed markers are shown on the display as a small delta (Δ), smaller than the inactive marker triangles (Δ).

Fixed markers are used to compare trace measurement values to some amplitude and frequency position which is a specificity or other limit. If you set the fixed marker's frequency to 0 Hz, the relative marker shows absolute frequency of a trace point and its amplitude value relative to the fixed marker.

The analyzer allows you to activate the fixed marker by pressing one of the following keys: Δ *MODE MENU*, Δ *REF=ΔFIXED MKR*, or *MKR ZERO*.

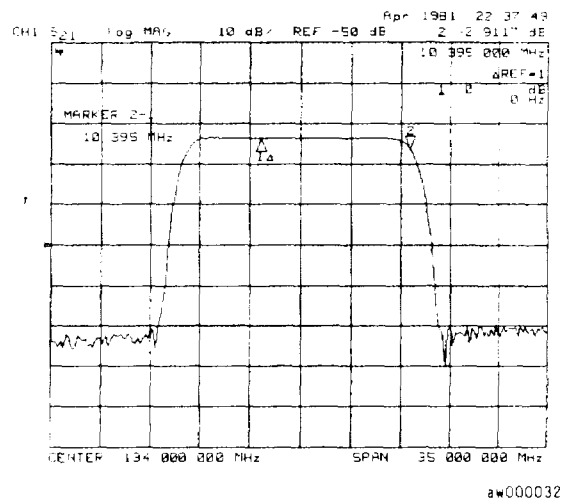

Figure 7-9. Example of Marker 1 as the Reference Marker

To display a delta marker

- 1** Press *MARKER*, Δ *MODE MENU*, Δ *REF = 1* to make marker 1 a reference marker.
- 2** To move marker 1 to any point that you want to reference:
 - Turn the front panel knob, *or*
 - Enter the frequency value (relative to the reference marker) on the numeric keypad.
- 3** Press *MARKER 2* and move marker 2 to any position that you want to measure in reference to marker 1.
- 4** To change the reference marker to marker 2, press Δ *MODE MENU*, Δ *REF = 2*.

To activate a fixed marker using Δ REF= Δ FIXED MKR

- 1** To set the frequency value of a fixed marker that appears on the analyzer display, press:

MARKER, Δ *MODE MENU*, Δ REF= Δ FIXED MKR, Δ *MODE MENU*, *FIXED MKR POSITION*, *FIXED MKR STIMULUS*, and turn the front panel knob.

The marker is shown on the display as a small delta (Δ), smaller than the inactive marker triangles.

- 2** To set the response value (dB) of a fixed marker, press:

FIXED MKR VALUE and turn the front panel knob.

In a Cartesian format, the setting is the y-axis value. In polar or Smith chart format, with a magnitude/phase marker, a real/imaginary marker, a R+jX marker, or a G+jB marker, the setting applies to the first part of the complex data pair. (Fixed marker response values are always uncoupled in the two channels.)

- 3** To set the auxiliary response value of a fixed marker when you are viewing a polar or Smith format, press:

FIXED MKR AUX VALUE and turn the front panel knob.

This value is the second part of complex data pair, and applies to a magnitude/phase marker, a real/imaginary marker, a R+jX marker, or a G+jB marker. (Fixed marker auxiliary response values are always uncoupled in the two channels.)

To activate a fixed marker using MKR ZERO

- 1** Press **MARKER**, and turn the front panel knob to establish the frequency position of the fixed marker. Use the keypad to enter a value of 0 Hz if you want delta measurements to show absolute frequency and relative amplitude.
- 2** Press **MKR ZERO** and turn the front panel knob.
- 3** Press **MARKER**, Δ **MODE MENU**, and notice that the Δ **REF = Δ FIXED MKR** softkey is selected.
- 4** Press **FIXED MKR POSITION**, **FIXED MKR STIMULUS** and turn the front panel knob to enter the fixed marker's frequency.
- 5** To set the amplitude of a fixed marker, press **FIXED MKR VALUE**, and turn the front panel knob.

In a Cartesian format, the setting is the y-axis value. In polar or Smith chart format, with a magnitude/phase marker, a real/imaginary marker, a $R+jX$ marker, or a $G+jB$ marker, the setting applies to the first part of the complex data pair. (Fixed marker response values are always uncoupled in the two channels.)

- 6** To set the auxiliary response value of a fixed marker when you are viewing a polar or Smith format, press **FIXED MKR AUX VALUE** and turn the front panel knob.

This value is the second part of complex data pair, and applies to a magnitude/phase marker, a real/imaginary marker, a $R+jX$ marker, or a $G+jB$ marker. (Fixed marker auxiliary response values are always uncoupled in the two channels.)

Searching with Markers

These functions place the marker at an amplitude-related point on the trace. If you switch on tracking, the HP 8702D searches every new trace for the target point.

The instrument can automatically calculate and display the -3 dB bandwidth (BW:), center frequency (CENT:), Q, and loss of the device under test. (Q stands for "quality factor," defined as the ratio of a circuit's resonant frequency to its bandwidth.) These values are shown in the marker data readout.

To search for minimum and maximum values

- 1** Press *MARKER FCTN*, *MKR SEARCH*.
- 2** Press *SEARCH: MAX* to move the active marker to the maximum point on the measurement trace.
- 3** Press *SEARCH: MIN* to move the active marker to the minimum point on the measurement trace.

To search for a specific amplitude

- 1 Press **MARKER FCTN**, *MKR SEARCH* to access the marker search menu.
- 2 Press *SEARCH: TARGET* to move the active marker to the target point on the measurement trace.
- 3 If you want to change the target amplitude value (default is -3 dB), press *TARGET* and enter the new value from the front panel keypad.
- 4 If you want to search for multiple responses at the target amplitude value, press *SEARCH LEFT* and *SEARCH RIGHT*.

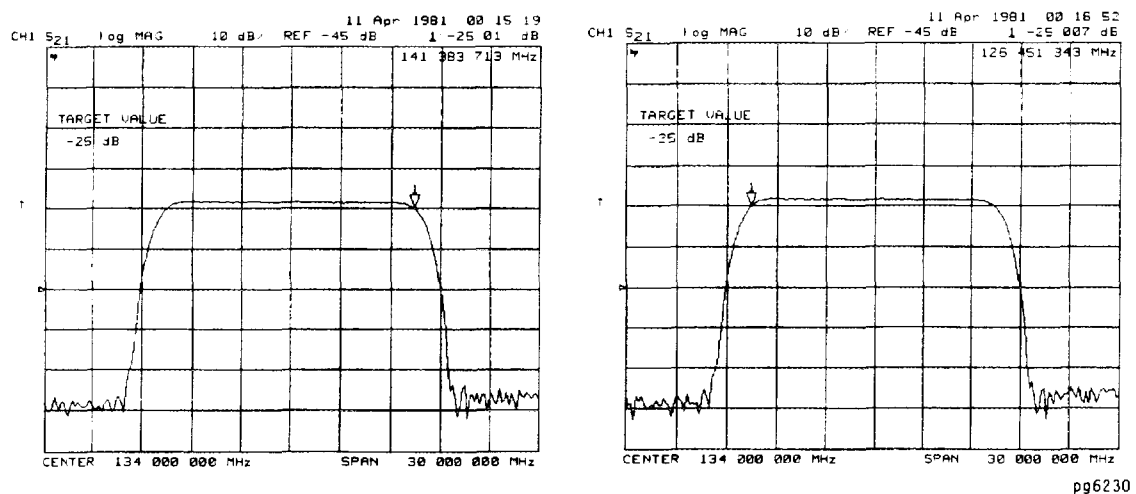

Figure 7-10. Example of Searching for a Target Amplitude Using a Marker

To search for a bandwidth

- 1 Press **MARKER** and turn the front panel knob to place the marker at the center of the filter passband.
- 2 Press **MKR ZERO**, **MARKER FCTN**, **MKR SEARCH** to access the marker search menu.
- 3 Press **WIDTHS ON** to calculate the center stimulus value, bandwidth, and the Q of a bandpass or band reject shape on the measurement trace, as shown in Figure 7-11.
- 4 If you want to change the amplitude value (default is -3 dB) that defines the passband or rejectband, press **WIDTH VALUE** and enter the new value from the front panel keypad.

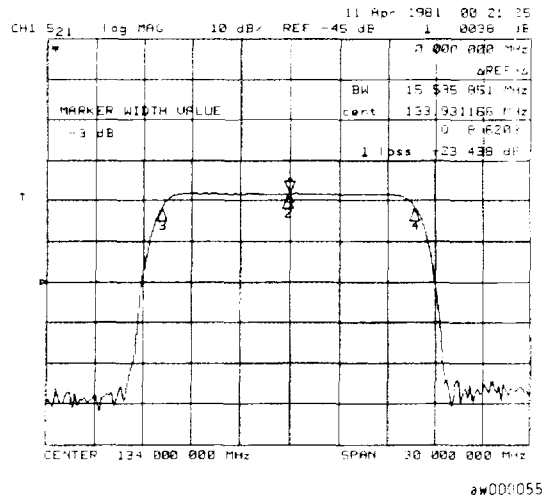

Figure 7-11. Example of Searching for a Bandwidth Using Markers

To track an amplitude value

- 1** Set up an amplitude search by following one of the previous procedures in “To search for a specific amplitude” on page 7-25.
- 2** Press **MARKER FCTN**, *MKR SEARCH*, *TRACKING ON* to track the specified amplitude search with every new trace and put the active marker on that point.

When tracking is not activated, the HP 8702D finds the specified amplitude on the current sweep and the marker remains at the same stimulus value, regardless of changes in the trace response value with subsequent sweeps.

Making Statistical Measurements

Marker statistics calculate the mean, standard deviation, and peak-to-peak values of the section of the displayed trace between the active marker and the delta reference. If there is no delta reference, the HP 8702D calculates the statistics for the entire trace.

An application for this feature is to find the peak-to-peak value of passband ripple without searching separately for the maximum and minimum values.

If you are viewing a measurement in the polar or Smith chart format, the HP 8702D calculates the statistics using the first value of the complex pair (magnitude, real part, resistance, or conductance).

To calculate the statistics of the measurement data

- 1 Press **MARKER**, Δ **MODE MENU**, Δ **REF = 1** to make marker 1 a reference marker.
- 2 Move marker 1 to any point that you want to reference:
 - Turn the front panel knob, *or*
 - Enter the frequency value on the numeric keypad.
- 3 Press **RETURN**, **MARKER 2** and move marker 2 to any position that you want to measure in reference to marker 1.
- 4 Press **MARKER FCTN**, **MARKER MODE MENU**, **STATS ON** to calculate and view statistics on the measurement data between the active marker and the delta reference marker, as shown in Figure 7-12.

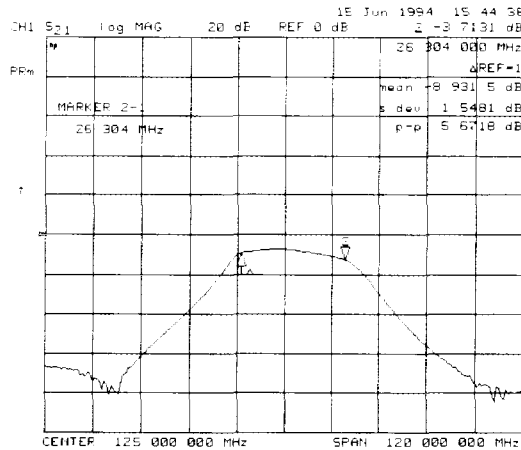

Figure 7-12. Example of the Statistics of Measurement Data

Using Markers with Other Display Formats

Polar displays

The HP 8702D can display the marker value as magnitude and phase, or as a real/imaginary pair: *LIN MKR* gives linear magnitude and phase, *LOG MKR* gives log magnitude and phase, *Re/Im MKR* gives the real value first, then the imaginary value.

You can use these markers only when you are viewing a polar display format. (The format is available from the *FORMAT* key.)

Smith chart displays

The amount of power reflected from a device is directly related to the impedance of the device and the measuring system. Each value of the reflection coefficient (Γ) uniquely defines a device impedance; $\Gamma = 0$ only occurs when the device and HP 8702D impedance are exactly the same. The reflection coefficient for a short circuit is: $\Gamma = 1 \angle 180^\circ$. Every other value for Γ also corresponds uniquely to a complex device impedance, according to the equation:

$$Z_L = [(1 + \Gamma) / (1 - \Gamma)] \times Z_0$$

where Z_L is your test device impedance and Z_0 is the measuring system's characteristic impedance (50 Ω or 75 Ω).

To use polar format markers

1 To access the polar markers, press:

FORMAT, *POLAR*
MARKER FCTN, *MARKER MODE MENU*, *POLAR MKR MENU*

2 Select the type of polar marker you want from the following choices:

- *LIN MKR* if you want to view the magnitude and the phase of the active marker. The magnitude values appear in units and the phase values appear in degrees.
- *LOG MKR* if you want to view the logarithmic magnitude and the phase of the active marker. The magnitude values appear in dB and the phase values appear in degrees, as shown in Figure 7-13.
- *Re/Im MKR* if you want to view the real and imaginary pair, where the complex data is separated into its real part and imaginary part. The HP 8702D shows the first marker value as the real part ($M \cos \theta$), and the second value as the imaginary part ($M \sin \theta$, where M =magnitude).

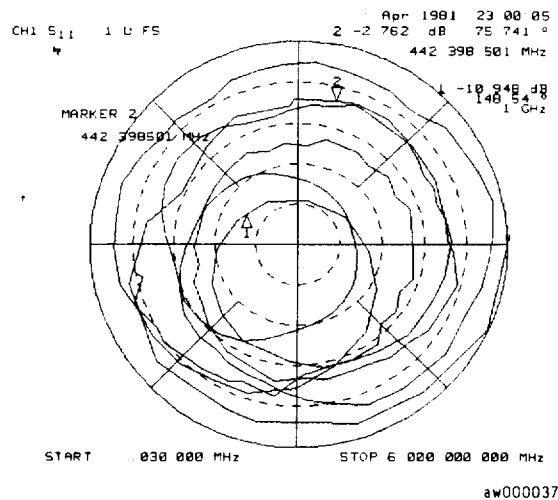

Figure 7-13. Example of a Log Marker in Polar Format

To use Smith chart markers

- 1 Press **FORMAT**, *SMITH CHART*.
- 2 Press **MARKER**, *MARKER MODE MENU*, *SMITH MKR MENU* and turn the front panel knob to read the resistive and reactive components of the complex impedance at any point along the trace. This is the default Smith chart marker.

The marker annotation tells that the complex impedance is capacitive in the bottom half of the Smith chart display and is inductive in the top half of the display, as shown in Figure 7-14.

- Choose *LIN MKR* if you want the HP 8702D to show the linear magnitude and the phase of the reflection coefficient at the marker.
- Choose *LOG MKR* if you want the HP 8702D to show the logarithmic magnitude and the phase of the return loss at the active marker. This is useful as a fast method of obtaining a reading of the log magnitude value without changing to log magnitude format.
- Choose *Re/Im MKR* if you want the HP 8702D to show the values of the reflection coefficient at the marker as a real and imaginary pair.
- Choose *R+jX MKR* to show the real and imaginary parts of the device impedance at the marker. Also shown is the equivalent series inductance or capacitance (the series resistance and reactance, in ohms).
- Choose *G+jB MKR* to change the display to an inverse Smith chart graticule and the marker information to read admittance.

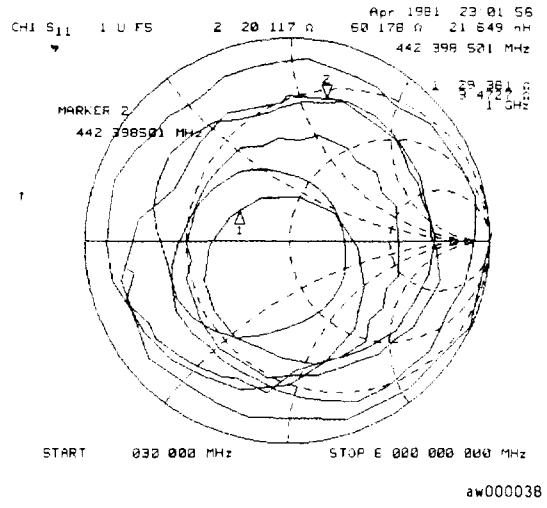

Figure 7-14. Example of Impedance Smith Chart Markers

Making Other Measurements

The measurement examples in this section assume that you have already captured transmission or reflection measurement data. These specific measurements show you practical examples for using markers.

The following measurements are for transmission data:

- To measure 3 dB bandwidth 7-35
- To measure out-of-band rejection 7-36
- To measure passband flatness or ripple 7-37

The following measurements are for reflection data:

- To measure reflection coefficient 7-38
- To measure standing wave ratio 7-39
- To measure S11 and S22 in a polar format 7-40
- To measure impedance 7-42
- To measure admittance 7-44

To measure 3 dB bandwidth

This procedure calculates the -3 dB bandwidth (relative to the center frequency) of a bandpass filter.

- 1 Press **MARKER**, and turn the front panel knob to move the marker to the center frequency position of the filter passband.
- 2 Press **MKR ZERO** to zero the delta marker magnitude and frequency.

This sets the delta marker reference. The -3 dB points will be relative to this marker. The softkey label changes to **MKR ZERO Δ REF = Δ** to show you that the delta reference point is the small Δ symbol.

- 3 Press **MARKER FCTN**, **MKR SEARCH ON OFF** to enter the marker search mode.
- 4 Press **WIDTHS ON**.

The HP 8702D calculates the -3 dB bandwidth, the center frequency and the Q (quality factor) of the test device and lists the results in the upper-right corner of the display. Markers 3 and 4 indicate the location of the -3 dB points, as shown in Figure 7-15.

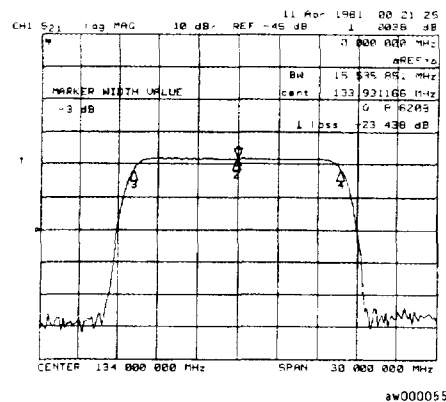

Figure 7-15. Example Measurement of 3 dB Bandwidth

- 5 Press **WIDTH VALUE**, and enter $-6, x1$.

The HP 8702D calculates the bandwidth between -6 dB power levels.

To measure out-of-band rejection

1 Press **MARKER**, and turn the front panel knob to move the marker to the center frequency position of the filter passband.

2 Press **MKR ZERO**, **MARKER FCTN**, **MKR SEARCH**, **SEARCH: MIN**.

The marker automatically searches for the minimum point on the trace. The frequency and amplitude of this point, appear in the upper-right corner of the display. This value is the difference between the maximum power in the passband and the power in the rejection band, that is, one of the peaks in the rejection band.

3 If your measurement needs some noise reduction, you could reduce the IF bandwidth or add averaging.

- To reduce the IF bandwidth, press **AVG**, **IF BW**, **↓**.
- To add averaging, press **AVG**, **AVERAGING ON**.

To measure passband flatness or ripple

Passband flatness (or ripple) is the variation in insertion loss over a specified portion of the passband, as shown in Figure 7-16.

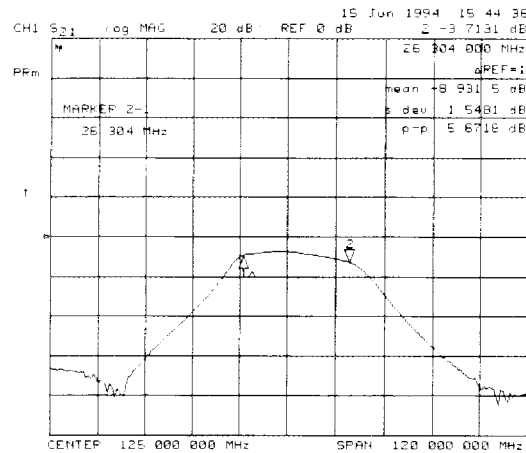

Figure 7-16. Example Measurement of Passband Flatness or Ripple

- 1 Press **MARKER**, and turn the front panel knob to move marker 1 to the left edge of the passband.
- 2 Press Δ **MARKER MENU**, Δ **REF = 1** to change the marker 1 position to the delta reference point.
- 3 Press **MARKER 2**, and turn the front panel knob to move marker 2 to the right edge of the passband.
- 4 Press **MARKER FCTN**, **MARKER MODE MENU**, **STATS ON**.

The HP 8702D calculates the mean, standard deviation, and peak-to-peak variation between the Δ reference marker and the active marker, and lists the results in the upper-right corner of the display. The passband ripple is automatically shown as the peak-to-peak variation between the markers.

To measure reflection coefficient

- 1 Press **FORMAT**, *LIN MAG*, **SCALE REF**, *AUTO SCALE* so that the HP 8702D shows the same data, in terms of reflection coefficient, as shown in Figure 7-17.
- 2 Press **MARKER**.

The units "mU" displayed on the HP 8702D are "milli-units," where "units" or "U" is used to indicate that the parameter is unitless (as opposed to log or linear). For example, 200 mUnits = 0.2.

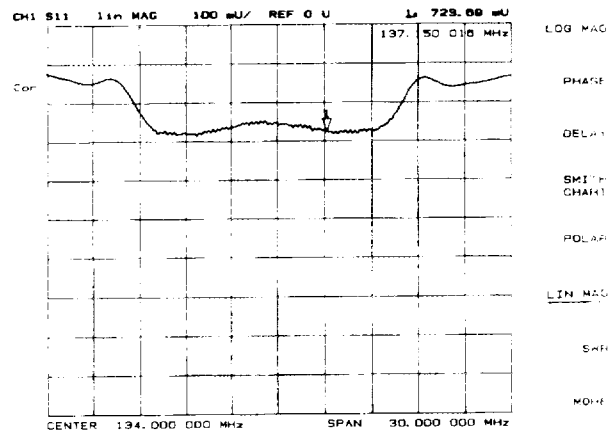

pg6174

Figure 7-17. Example Reflection Coefficient Measurement Trace

To measure standing wave ratio

- 1 Press **FORMAT**, **SWR** so the HP 8702D shows the same data, in terms of standing-wave-ratio (SWR), as shown in Figure 7-18.
- 2 Press **MARKER**.

The display shows the measurement data in the unitless measure of SWR where $SWR = 1$ (perfect match) at the bottom of the display.

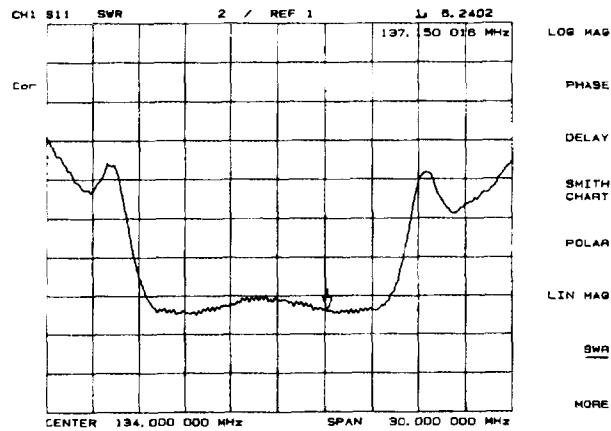

pg6175_c

Figure 7-18. Example Standing-Wave-Ratio Measurement Trace

To measure S_{11} and S_{22} in a polar format

S_{11} is a measurement parameter used to measure the reflection coefficient of your test device input, where S_{22} is a measurement parameter used to measure the reflection coefficient of the test device's output. In both instances, you must terminate all the unused ports.

- 1 Press **FORMAT**, *POLAR*.
- 2 Press **SCALE REF**, *AUTO SCALE* to reposition the trace as shown in Figure 7-19.

The HP 8702D shows the results of an S_{11} measurement with each point on the polar trace corresponding to a particular value of both magnitude and phase. The center of the circle represents a reflection coefficient (Γ) of 0, (that is, a perfect match or no reflected signal). The outermost circumference of the scale shown in Figure 7-19 represents $\rho = 2.00$, or 200% reflection. The phase angle is read directly from this display. The 3 o'clock position corresponds to zero phase angle (that is, the reflected signal is at the same phase as the incident signal). Phase differences of 90° , 180° , and -90° correspond to the 12 o'clock, 9 o'clock, and 6 o'clock positions on the polar display, respectively.

- 3 Press **MARKER FCTN**, *MARKER MODE MENU*, *POLAR MKR MENU*.

4 Turn the front panel knob to position the marker at any desired point on the trace, then read the frequency, linear magnitude and phase in the upper right hand corner of the display, as shown in Figure 7-19.

- Choose *LIN MKR* if you want the HP 8702D to show the linear magnitude and the phase of the marker.
- Choose *LOG MKR* if you want the HP 8702D to show the logarithmic magnitude and the phase of the active marker. This is useful as a fast method of obtaining a reading of the log-magnitude value without changing to log-magnitude format.
- Choose *Re/Im MKR* if you want the HP 8702D to show the value of the marker as a real and imaginary pair.

You can also enter the frequency of interest, from either the attached keyboard or the numeric keyboard, and read the magnitude and phase at that point.

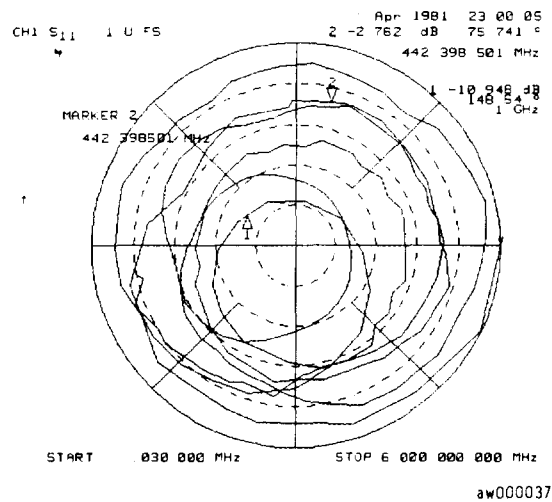

Figure 7-19. Example S₁₁ Measurement Trace in Polar Format with Markers

To measure impedance

The amount of power reflected from a device is directly related to the impedance of the device and the measuring system. Each value of the reflection coefficient (Γ) uniquely defines a device impedance: $\Gamma = 0$ only occurs when the device and HP 8702D impedance are exactly the same. The reflection coefficient for a short circuit is: $\Gamma = 1 \angle 180^\circ$. Every other value for Γ also corresponds uniquely to a complex device impedance, according to the equation:

$$Z_L = [(1 + \Gamma) / (1 - \Gamma)] \times Z_0$$

where Z_L is your test device impedance and Z_0 is the measuring system's characteristic impedance (50Ω or 75Ω).

- 1 Press **FORMAT**, *SMITH CHART*.
- 2 Press **MARKER FCTN**, *MARKER MODE MENU*, *SMITH MKR MENU*, and turn the front panel knob to read the resistive and reactive components of the complex impedance at any point along the trace, as shown in Figure 7-20. This is the default Smith chart marker.

The marker annotation tells that the complex impedance is capacitive in the bottom half of the Smith chart display and is inductive in the top half of the display.

- Choose *LIN MKR* if you want the HP 8702D to show the linear magnitude and the phase of the reflection coefficient at the marker.
- Choose *LOG MKR* if you want the HP 8702D to show the logarithmic magnitude and the phase of the reflection coefficient at the active marker. This is useful as a fast method of obtaining a reading of the log magnitude value without changing to log magnitude format.
- Choose *Re/Im MKR* if you want the HP 8702D to show the values of the reflection coefficient at the marker as a real and imaginary pair.
- Choose *R+jX MKR* to show the real and imaginary parts of the device impedance at the marker. Also shown is the equivalent series inductance or capacitance (the series resistance and reactance, in ohms).

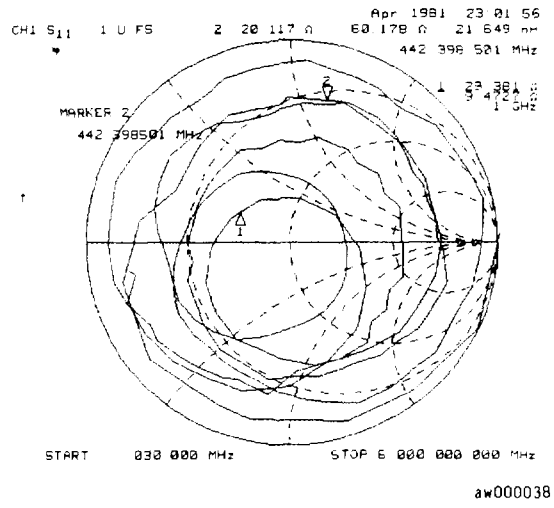

Figure 7-20. Example Impedance Measurement Trace

To measure admittance

To change the display to an inverse Smith chart graphic and the marker information to read admittance:

- 1 Press **FORMAT**, *SMITH CHART*.
- 2 Press **MARKER FCTN**, *MARKER MODE MENU*, *SMITH MKR MENU*, and turn the front panel knob to read the resistive and reactive components of the complex impedance at any point along the trace, as shown in Figure 7-20. This is the default Smith chart marker. Press *G+jB MKR*.

The marker reads admittance data in the form $G+jB$, where G is conductance and B is susceptance, both measured in units of Siemens (equivalent to mhos: the inverse of ohms). Also shown is the equivalent parallel capacitance or inductance.

Making Mixer Measurements

Making Mixer Measurements

What you'll find in this chapter

Measurement Considerations	8-3
Conversion Loss Using the Frequency Offset Mode	8-4
Sequence 1 setup	8-15
Sequence 2 Setup	8-18
High Dynamic Range Swept RF/IF Conversion Loss	8-11
Conversion Loss Using the Tuned Receiver Mode	8-14
Phase or Group Delay Measurements	8-20
Conversion Compression Using the Frequency Offset Mode	8-23
Isolation Example Measurements	8-28
Power Meter Calibration for Mixer Measurements	8-34

Measurement Considerations

Mixers pose some unique measurement challenges that can be addressed by careful attention to port matching, spurious responses, and correct filtering of the IF signal.

Attenuation at mixer ports

When characterizing linear devices, you can use vector accuracy enhancement to mathematically remove all systematic errors, including source and load mismatches, from your measurement. This is not possible when the device you are characterizing is a mixer operating over multiple frequency ranges. Therefore, source and load mismatches are not corrected for, and will add to, overall measurement uncertainty.

You should place attenuators at all of the mixer's ports to reduce the measurement errors associated with the interaction between mixer port matches and system port matches. To avoid overdriving the receiver, give extra care when selecting the attenuator located at the mixer's IF port. For best results, choose the attenuator value so that the power incident on the analyzer R-channel input is less than -10 dBm.

Frequency selection

By choosing test frequencies (frequency list mode), you can reduce the effect of spurious responses on measurements by avoiding frequencies that produce IF signal path distortion.

Filtering

By placing filters between the mixer's IF port and the receiver's input port, you can eliminate unwanted mixing and leakage signals from entering the analyzer's receiver. Filtering is required in both fixed and broadband measurements. Therefore, when configuring broadband (swept) measurements, you may need to trade some measurement bandwidth for the ability to more selectively filter signals entering the analyzer receiver.

Conversion Loss Using the Frequency Offset Mode

Conversion loss is the measure of efficiency of a mixer. It is the ratio of sideband IF power to RF signal power, and is usually expressed in dB. The mixer translates the incoming signal (RF), to a replica (IF), displaced in frequency by the local oscillator (LO). Frequency translation is characterized by a loss in signal amplitude and the generation of additional sidebands. For a given translation, two equal output signals are expected, a lower sideband and an upper sideband.

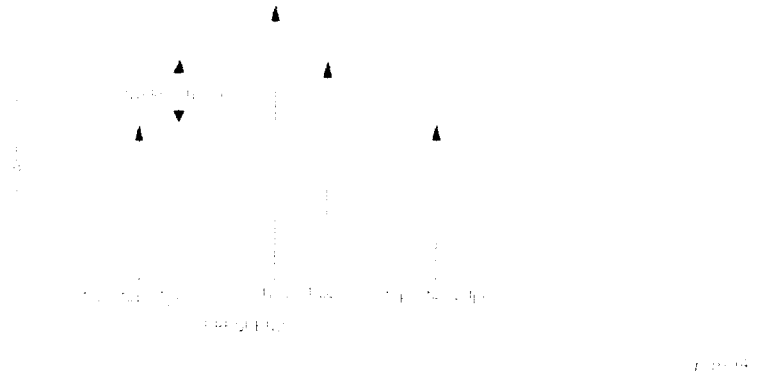

Figure 8-1. An Example Spectrum of RF, LO, and IF Signals Present in a Conversion Loss Measurement

Swept RF/IF mixer measurements

The HP 8702D allows you to make a swept RF/IF conversion loss measurement. You can make this measurement by using the analyzer's frequency offset measurement mode.

Frequency offset mode

This mode of operation allows you to offset the analyzer's source by a fixed value, above or below the HP 8702D's receiver. That is, this allows you to use a device input frequency range that is different for the receiver input frequency range.

The following procedure describes the swept IF frequency conversion loss measurement of a broadband component mixer.

- 1 Before disconnecting the R-channel jumper, set the frequency offset mode to *ON* to prevent an improper automatic phaselock calibration from occurring. Once activated, the phaselock search range is limited to the range being measured. To activate the frequency offset mode, press:

SYSTEM, INSTRUMENT MODE, FREQ OFFS MENU, FREQ OFFS ON

Since the LO (offset) frequency is still set to 0 Hz, the analyzer will operate normally. Remove the R-channel jumper and connect the analyzer source output, port 1, directly to the to the R-channel input as shown in Figure 8-2. The analyzer will display an error message briefly as the R-channel phase lock signal is lost, but will remove the message as the new R-channel reference is connected.

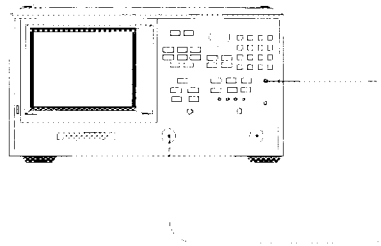

pa504 1c

Figure 8-2. R-Channel External Connection

Conversion Loss Using the Frequency Offset Mode

- 2 Measure the output power in the R-channel by pressing:

MEAS, INPUT PORTS, R

Observe the 16 dB offset in measured power due to compensation for the internal losses in the test set. This difference must be accounted for before performing measurements. The actual input power level to the R-channel input must be 0 dBm or less, -10 dBm typical, to avoid receiver saturation effects. The minimum signal level must be greater than -35 dBm to provide sufficient signal for operation of the phaselock loop.

- 3 Add the pads and low pass filter to the measurement loop as shown in Figure 8-3. The low pass filter is required to limit the range of frequencies passed into the R-channel input port. The filter is selected to pass the IF frequencies for the measurement, but prevent the LO feedthrough and unwanted mixer products from confusing the phase lock loop operation. A pad is used to terminate the filter and another pad is used to improve the RF port match for the mixer. These pads and filter are present in the measurement path when testing the mixer and must be accounted for to properly measure the insertion loss of the mixer.

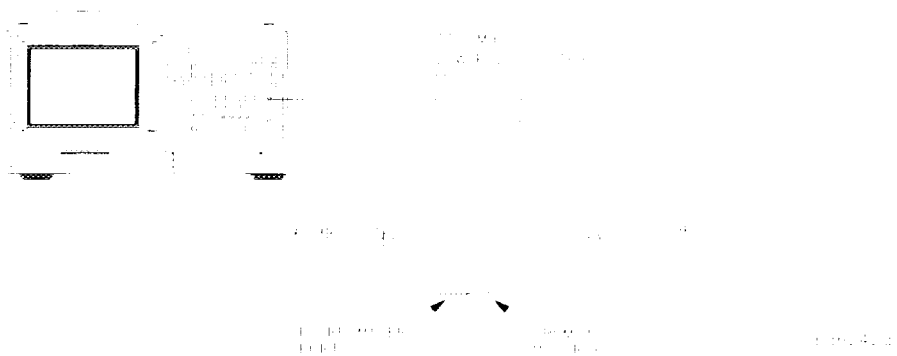

Figure 8-3. Measurement Path Calibration Setup

- 4 Set the IF frequency to the desired measurement range, which must be within the passband of the filter, by pressing:

START, 100, M/ μ
STOP, 350, M/ μ

There should be no error messages displayed and R-channel power should read 13 to 16 dB higher than the actual power. This level will appear as 0 dBm since the pads present 16 dB of loss.

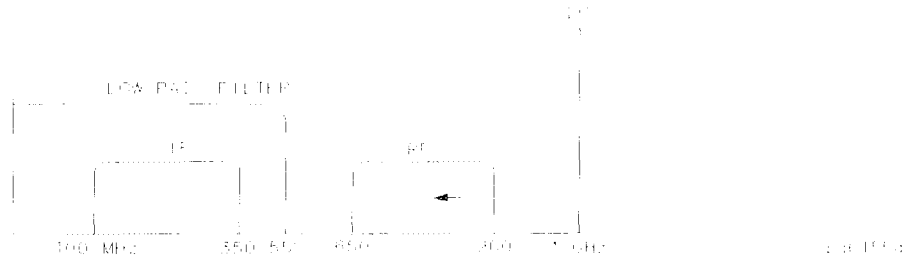

Figure 8-4. Diagram of Measurement Frequencies

- 5 Set the desired source power to the value which will provide -10 dBm to the R-channel input. For the network connected in this example, $+6$ dBm would be required to provide 0 dBm to the RF mixer port. Setting the power range to manual prevents the internal source attenuator from switching when changing power levels. If you choose a different power range, the R-channel offset compensation and R-channel measurement changes by the amount of the attenuator setting. Press:

MENU, POWER, PWR RANGE MAN, 6, x1

- 6 Changing power ranges requires recalibrating the R-channel. You cannot trust R-channel power settings without knowing about the offset involved. Perform a response calibration to remove any offsets by pressing:

CAL, CALIBRATE MENU, RESPONSE, THRU, DONE

Once completed, the R-channel should display 0 dB.

- 7 Setup the LO source for the mixer to the desired CW frequency and power level. For this example, the LO source is set to the following values:

CW frequency = 1 GHz
Power = 13 dBm

- 8 Insert the mixer into the measurement configuration as shown in Figure 8-5.

Conversion Loss Using the Frequency Offset Mode

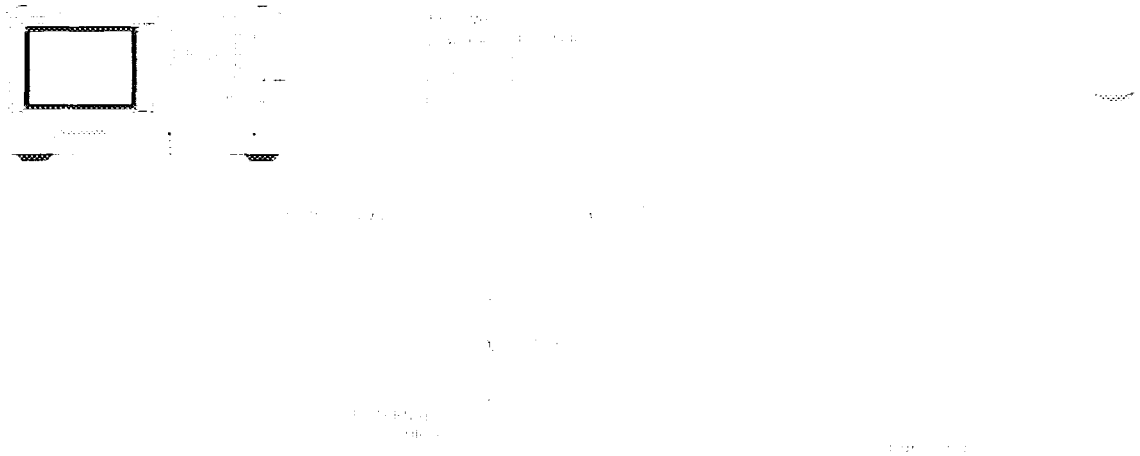

Figure 8-5. Connections for a Conversion Loss Measurement

- 9 The measurement does not begin until the frequency offset mode LO frequency is also set and frequency offset mode operation begins. The LO frequency for frequency offset mode in the analyzer must also be set to the same value as the external source. The offset frequency between the analyzer source and receiver will be set to this value. At this step, the receiver locks onto the IF signal frequencies and then generates the source frequencies, offset by the LO frequency. Press:

SYSTEM, INSTRUMENT MODE, FREQ OFFS MENU, LO MENU, FREQUENCY: CW, 1, G/n

- 10 The power level may be entered for documentation purposes, but does not control the LO power level. Press:

POWER: FIXED, 13, x1, RETURN

- 11 Select the converter type, down converter, and high-side LO measurement conversion, by pressing:

DOWN CONVERTER, RF < LO

In this high-side LO, down conversion configuration, the analyzer's source is actually sweeping backwards, as shown in Figure 8-7. The measurements setup diagram is shown in Figure 8-6.

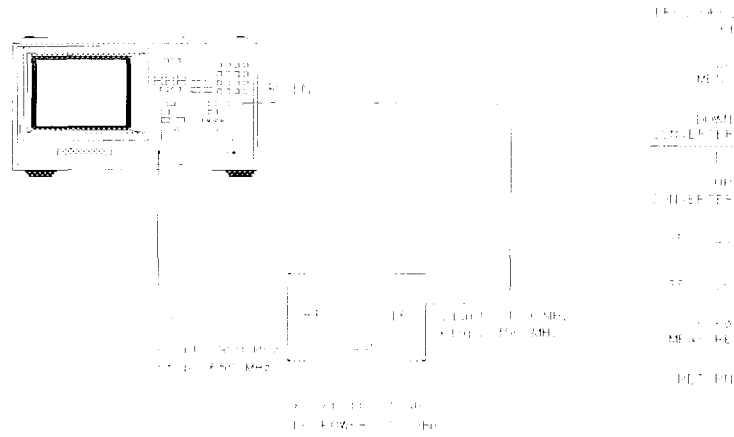

Figure 8-6. Measurement Setup from Display

Conversion Loss Using the Frequency Offset Mode

- 12** To measure the conversion loss as shown in Figure 8-7, press:

VIEW MEASURE

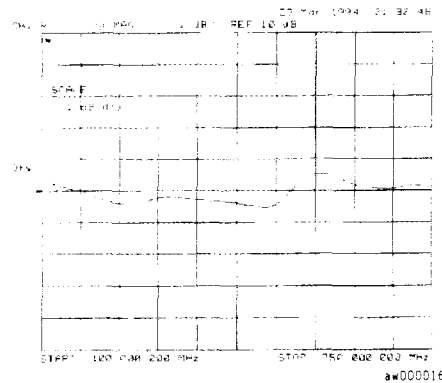

Figure 8-7. Conversion Loss Example Measurement

- 13** Scale the data for best vertical resolution, by pressing

SCALE REF, AUTO SCALE

In this measurement, you set the input power and measured the output power. Figure 8-7 shows the absolute loss through the mixer versus mixer output frequency.

Amplitude accuracy is affected by changing the source frequency after calibration. Amplitude variation is specified to ± 1 dB over any given source frequency. This may give a maximum of 2 dB error for this test setup: ± 1 dB for the source over the IF range during calibration and ± 1 dB over the RF range during measurement. Higher measurement accuracy may be obtained through the use of power meter calibration as discussed in "Power Meter Calibration for Mixer Measurements" on page 8-34.

This measurement process should be used to establish proper operation before attempting the power meter calibration to obtain increased accuracy. Be sure to establish proper operation first. Once good results are obtained, add in the power meter calibration steps.

High Dynamic Range Swept RF/IF Conversion Loss

The HP 8702D's frequency offset mode enables the testing of high dynamic range frequency converters (mixers), by tuning the analyzer's high dynamic range receiver above or below its source, by a fixed offset. This capability allows the complete measurement of both pass and reject band mixer characteristics.

The analyzer has a 35 dB dynamic range limitation on measurements made directly with its R (phaselock) channel. For this reason, the measurement of high dynamic range mixing devices (such as, cable television upconverter modules), with greater than 35 dB dynamic range, must be made on either the analyzer's A or B channel, with a reference mixer providing input to the analyzer's R channel for phaselock.

This example describes the swept IF conversion loss measurement of a high dynamic range 640 to 660 MHz, cable television frequency up-converter module. This up-converter module contains internal amplification and output filtering.

- 1 Set the LO source to the desired CW frequency and power level. For this example the values are as follows:
 - CW frequency = 416 MHz
 - Source power = 16 dBm
- 2 Press the following keys on the analyzer front panel to set the desired receiver frequency and source output power:
 - PRESET, SYSTEM, *INSTRUMENT MODE*, *FREQ OFFS MENU*, *FREQ OFFS ON*
 - START, 640, x1
 - STOP, 660, x1
 - MENU, *STIMULUS MENU*, *POWER*, *PWR RANGE MAN*, -4, x1

Making Mixer Measurements
High Dynamic Range Swept RF/IF Conversion Loss

- 3 Make the connections shown in Figure 8-8.

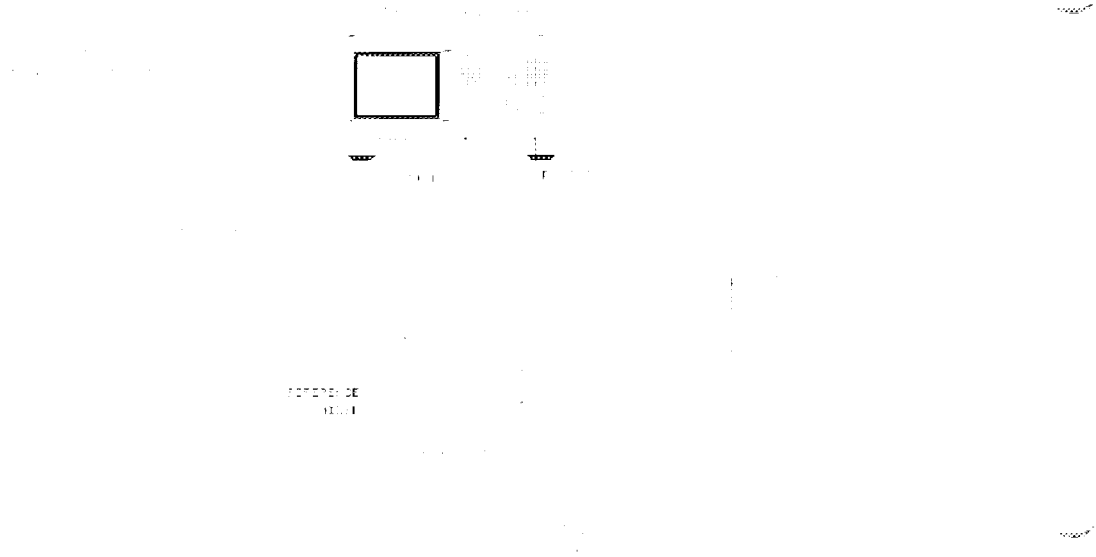

Figure 8-8. Connections for a High Dynamic Range Swept IF Conversion Loss Measurement

- 4 To view the absolute input power to the analyzer's B channel, press:
MEAS, INPUT PORTS, B
- 5 To set the frequency offset mode LO frequency, press:
SYSTEM, INSTRUMENT MODE, FREQ OFFS MENU, LO MENU, FREQUENCY: CW, 416, M/μ
- 6 To select the converter type and low-side LO measurement configuration, press:

RETURN, UP CONVERTER, RF > LO

In this low-side LO, up converter measurement, the analyzer's source frequency range is set to equal the receiver frequency range:

$$\text{receiver frequency range (640-660 MHz)} - \text{LO frequency (416 MHz)} = 224\text{-}244 \text{ MHz}$$

7 To view the conversion loss in the best vertical resolution, press:

VIEW MEASURE, SCALE REF, AUTO SCALE

Figure 8-9 shows the conversion loss of this low-side LO, cable television up converter.

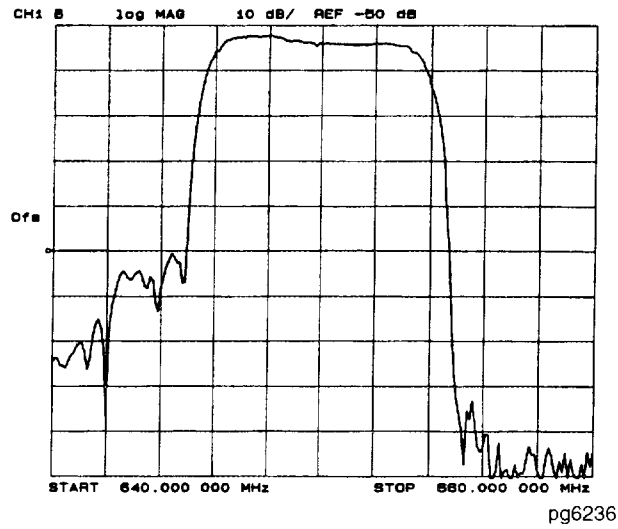

Figure 8-9. Example of Swept IF Conversion Loss Measurement

Conversion Loss Using the Tuned Receiver Mode

Fixed IF mixer measurements

This measurement requires two external RF sources as stimuli. Figure 8-10 on page 8-15 shows the hardware configuration for the fixed IF conversion loss measurement. This example measurement procedure uses the analyzer's test sequence function for automatically controlling the two external synthesizers (with SCPI commands), and making a conversion loss measurement in tuned receiver mode. The test sequence function is an instrument automation feature internal to the analyzer. For more information on the test sequence function refer to Chapter 11, "Creating Sequences", or to *Product Note HP 8753-3* (HP part no. 08753-90133).

Tuned receiver mode

The analyzer's tuned receiver mode allows you to tune its receiver to an arbitrary frequency and measure signal power. This is only possible if the signal we wish to analyze is at an exact known frequency. Therefore, the RF and LO sources must be synthesized and synchronized with the HP 8702D's time base. Since the analyzer is not phaselocked in this configuration, you can use it to measure conversion loss of a microwave mixer with an RF frequency range output.

Sequence 1 setup

The following sequence initializes the analyzer and the two external sources prior to measurement. This initialization includes:

- addressing and configuring the two sources
- putting the analyzer into tuned receiver mode
- setting up a frequency list sweep of 26 points
- initializing a loop counter value to 26
- calling the next measurement sequence

- 1 Make the following connections as shown in Figure 8-10. Set the HP-IB address of the external source to 19, and the external LO source to 21.

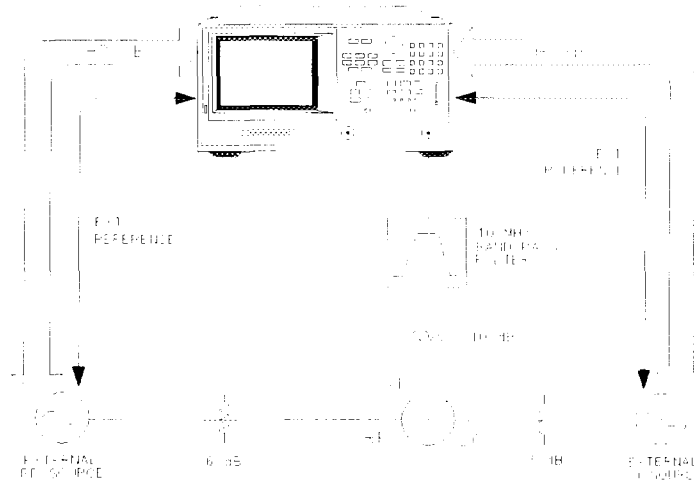

Figure 8-10. Connections for a Conversion Loss Using the Tuned Receiver Mode

- 2 Press the following keys on the analyzer to create sequence 1:
SEQ, NEW SEQ/MODIFY SEQ, SEQUENCE 1 SEQ1
SAVE/RECALL, SELECT DISK, INTERNAL MEMORY, RETURN, RECALL STATE
LOCAL, SYSTEM CONTROLLER
SYSTEM, INSTRUMENT MODE, TUNED RECEIVER
MENU, SWEEP TYPE MENU, EDIT LIST, ADD, CW FREQ, 10, M/ μ ,
NUMBER of POINTS, 26, x1, DONE, DONE, LIST FREQ

Conversion Loss Using the Tuned Receiver Mode

SEQ, *SPECIAL FUNCTIONS, DECISION MAKING, LOOP COUNTER*, 26, x1
MEAS, *INPUT PORTS, B*
SCALE REF, 2, x1, *REFERENCE POSITION*, 0, x1, *REFERENCE VALUE*, -20, x1
MENU, *TRIGGER MENU, MANUAL TRG ON POINT*
DISPLAY, *MORE, TITLE, ERASE TITLE, SELECT LETTER*, put in title: *POW:LEV 6DBM, DONE*
SEQ, *SPECIAL FUNCTIONS, PERIPHERAL HPIB ADDR*, 19, x1, *TITLE TO PERIPHERAL*
DISPLAY, *MORE, TITLE, ERASE TITLE, SELECT LETTER*, put in title: *FREQ:MODE CW;CW 1GHZ;;FREQ:CW:STEP 1GHZ, DONE*
SEQ, *SPECIAL FUNCTIONS, PERIPHERAL HPIB ADDR*, 19, x1, *TITLE TO PERIPHERAL*
DISPLAY, *MORE, TITLE, ERASE TITLE, SELECT LETTER*, put in title: *POW:LEV 13DBM, DONE*
SEQ, *SPECIAL FUNCTIONS, PERIPHERAL HPIB ADDR*, 21, x1, *TITLE TO PERIPHERAL*
DISPLAY, *MORE, TITLE, ERASE TITLE, SELECT LETTER*, put in title: *FREQ:MODE CW;CW 1.01GHZ;;FREQ:CW:STEP 1GHZ, DONE*
SEQ, *SPECIAL FUNCTIONS, PERIPHERAL HPIB ADDR*, 21, x1, *TITLE TO PERIPHERAL*
SEQ, *DO SEQUENCE, SEQUENCE 2 SEQ2*
SEQ, *DONE SEQ MODIFY*

The analyzer will display a sequence as follows:

```
SEQUENCE SEQ1
  Start of Sequence
RECALL PRST STATE
  SYSTEM CONTROLLER
TUNED RECEIVER
EDIT LIST
ADD
CW FREQ
  10M/u
NUMBER OF POINTS
  26x1
DONE
DONE
LIST FREQ
LOOP COUNTER
  26x1
  B
SCALE/DIV
  2 x1
REFERENCE POSITION
  0 x1
REFERENCE VALUE
  -20x1
MANUAL TRG ON POINT
TITLE
  POW:LEV 6DBM
PERIPHERAL HPIB ADDR
  19x1
TITLE TO PERIPHERAL
TITLE
  freq:mode cw;cw 1ghz;;freq:cw:step 1ghz
TITLE TO PERIPHERAL
TITLE
  pow:lev 13dbm
PERIPHERAL HPIB ADDR
  21x1
TITLE TO PERIPHERAL
TITLE
  freq:mode cw;cw 1.01ghz;;freq:cw:step 1ghz
TITLE TO PERIPHERAL
DO SEQUENCE
  SEQUENCE 2
```

Sequence 2 Setup

The following sequence makes a series of measurements until all 26 CW measurements are made and the loop counter value is equal to zero. This sequence includes:

- taking data
- incrementing the source frequencies
- decrementing the loop counter
- labeling the screen

1 Press the following keys on the analyzer to create sequence 2:

```
SEQ, NEW SEQ/MODIFY SEQ, SEQUENCE 2 SEQ2
MENU, TRIGGER MENU, MANUAL TRG ON POINT
DISPLAY, MORE, TITLE, ERASE TITLE, SELECT LETTER, put in title: FREQ: CW UP, DONE
SEQ, SPECIAL FUNCTIONS, PERIPHERAL HPiB ADDR, 19, x1,
TITLE TO PERIPHERAL, PERIPHERAL HPiB ADDR, 21, x1,
TITLE TO PERIPHERAL, DECISION MAKING, DECR LOOP COUNTER, IF LOOP COUNTER < 0,
SEQUENCE 2 SEQ2
DISPLAY, MORE, TITLE, ERASE TITLE, SELECT LETTER, put in title: MEASUREMENT COM-
PLETED, DONE
SEQ, DONE SEQ MODIFY
```

The analyzer will display a sequence as follows:

```
SEQUENCE SEQ2
Start of Sequence
MANUAL TRG ON POINT
TITLE
FREQ: CW UP
PERIPHERAL HPiB ADDR
19x1
TITLE TO PERIPHERAL
PERIPHERAL HPiB ADDR
21x1
TITLE TO PERIPHERAL
DECR LOOP COUNTER
IF LOOP COUNTER < 0 THEN DO
SEQUENCE 2
TITLE
MEASUREMENT COMPLETED
```

2 Press the following keys to run the sequences:

```
SEQ, DO SEQUENCE, SEQUENCE1 SEQ1
```

When the sequences are finished you should have a result as shown in Figure 8-11.

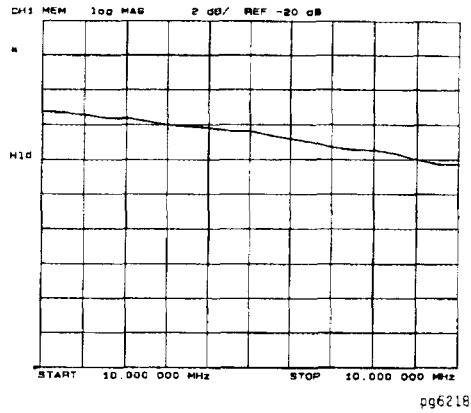

Figure 8-11. Example Fixed IF Mixer Measurement

Optional: For information on removing systematic frequency response errors, and on performing a source power meter calibration, refer to Chapter 6, "Optimizing Measurements".

Phase or Group Delay Measurements

- 1 Set the LO source to the desired CW frequency and power level. For this example, the LO source is set to the following values:
CW frequency = 1000 MHz
Power = 13 dBm
- 2 Initialize the analyzer by pressing PRESET on the HP 8702D.
- 3 From the front panel of the HP 8702D, set the desired receiver frequency and source output power, by pressing:
SYSTEM, INSTRUMENT MODE, FREQ OFFSET MENU, FREQ OFFSET ON
START, 100, M/μ
STOP, 350, M/μ
MENU, STIMULUS MENU, POWER, 0, x1
- 4 Connect the instruments as shown in Figure 8-12, placing a broadband "calibration" mixer between PORT 1 and PORT 2.

NOTE

You must activate the frequency offset mode *before* you disconnect the R-channel jumper.

CAUTION

To prevent connector damage, use an adapter (HP part number 1250-1462) as a connector saver for R CHANNEL IN.



Figure 8-12. Connections for a Phase or Group Delay Measurement

- 5** To make a response error-correction, press:
MEAS, INPUT PORTS, B/R
CAL, CALIBRATE MENU, RESPONSE, THRU, DONE RESPONSE
- 6** Replace the “calibration” mixer with the device under test, and set the delay equal to the “calibration” mixer delay (for example, -0.6 ns).
SCALE REF, ELECTRICAL DELAY, -0.6 , G/n
- 7** To set the frequency offset mode LO frequency from the analyzer, press:
SYSTEM, INSTRUMENT MODE, FREQ OFFS MENU, LO MENU,
FREQUENCY: CW, 1000, M/ μ , POWER: FIXED, 13, x1, RETURN
- 8** To select the converter type and a high-side LO measurement configuration, press:
DOWN CONVERTER, RF < LO
- 9** To view the measurement, press:
VIEW MEASURE
- 10** To select the format type, either press:
FORMAT, PHASE, or
FORMAT, DELAY

Phase or Group Delay Measurements

- 11 Scale the data for best vertical resolution, by pressing:

SCALE REF, AUTO SCALE

The displayed measurement trace shows the device under test delay, relative to the "calibration" mixer. This measurement is also useful when the device under test has built-in filtering, which requires >30 dB range (the maximum of R input). PORT 1 to PORT 2 range is >100 dB.

Conversion Compression Using the Frequency Offset Mode

Conversion compression is a measure of the maximum RF input signal level, where the mixer provides linear operation. The conversion loss is the ratio of the IF output level to the RF input level. This value remains constant over a specified input power range. When the input power level exceeds a certain maximum, the constant ratio between IF and RF power levels will begin to change. The point at which the ratio has decreased 1 dB is called the 1 dB compression point. Refer to Figure 8-13.

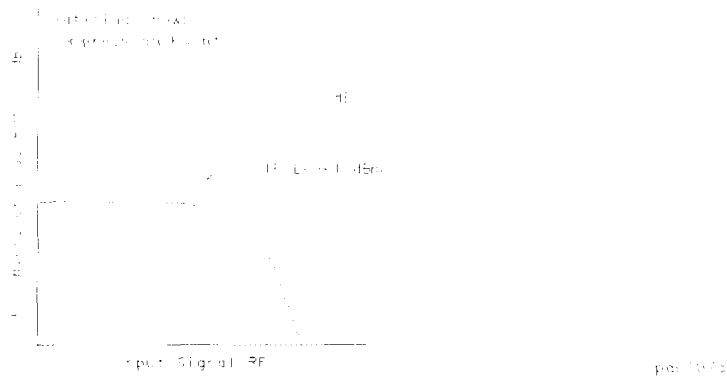

Figure 8-13. Conversion Loss and Output Power as a Function of Input Power Level

Notice that the IF output power increases linearly with the increasing RF signal, until mixer compression begins and the mixer saturates.

The following example uses a ratio of mixer output to input power and a marker search function to locate a mixer's 1 dB compression point.

- 1 Set the LO source to the desired CW frequency and power level from the front panel of the external source.

CW, 600, MHz
POWER, 13, dBm

Conversion Compression Using the Frequency Offset Mode

- 2 Initialize the analyzer by pressing PRESET.
- 3 To set the desired CW frequency and power sweep range, press:
SYSTEM, INSTRUMENT MODE, FREQ OFFSETS MENU, FREQ OFFSETS ON MENU, SWEEP TYPE MENU, POWER SWEEP, RETURN, CW FREQ, 800, M/μ
START, -10, x1
STOP, 10, x1
- 4 Make the connections, as shown in Figure 8-14.

CAUTION

To prevent connector damage, use an adapter (HP part number 1250-1462) as a connector saver for R CHANNEL IN.



Figure 8-14. Connections for the First Portion of Conversion Compression Measurement

- 5 To view the absolute input power to the analyzer's R-channel, press:
MEAS, INPUT PORTS, R
- 6 To store a trace of the receiver power versus the source power into memory and view data/memory, press:
DISPLAY, DATA → MEMORY, DATA/MEM

This removes the loss between the output of the mixer and the receiver and provides a linear power sweep for use in subsequent measurements.
- 7 Make the connections as shown in Figure 8-15.

CAUTION

To prevent connector damage, use an adapter (HP part number 1250-1462) as a connector saver for R CHANNEL IN.

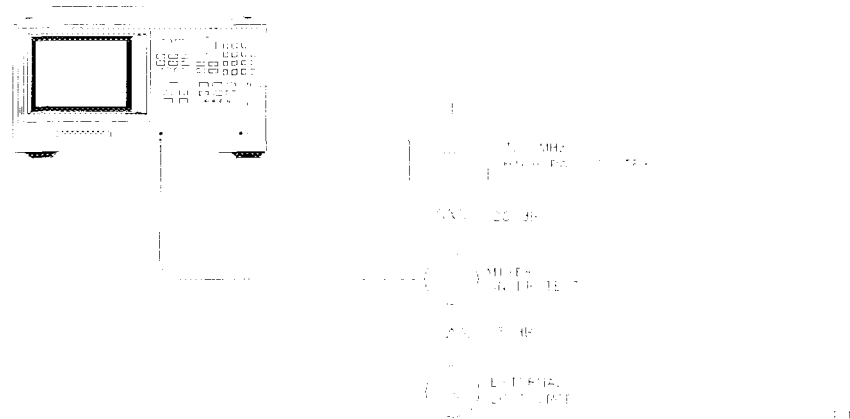

Figure 8-15. Connections for the Second Portion of Conversion Compression Measurement

- 8** To set the frequency offset mode LO frequency, press:

SYSTEM, INSTRUMENT MODE, FREQ OFFS MENU, LO MENU, FREQUENCY: CW, 600, M/μ, POWER: FIXED, 13, x1, RETURN

- 9** To select the converter type, press:

UP CONVERTER

- 10** To select a low-side LO measurement configuration, press:

RF > LO

In this high-side LO, up converter measurement, the analyzer source frequency is set to equal the receiver frequency:

$$800 \text{ MHz} - \text{LO frequency } 600 \text{ MHz} = 200 \text{ MHz}$$

The measurements setup diagram is shown in Figure 8-16.

Conversion Compression Using the Frequency Offset Mode

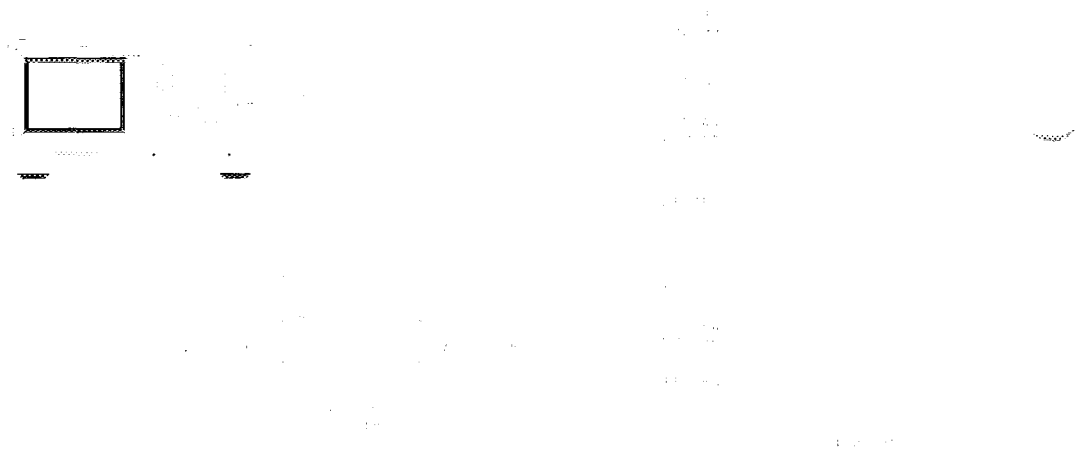

Figure 8-16. Measurement Setup Diagram Shown on Analyzer Display

- 11** To view the mixer's output power as a function of its input power, press:

VIEW MEASURE

- 12** To set up an active marker to search for the 1 dB compression point of the mixer, press:

SCALE REF, AUTO SCALE

MARKER, 0, x1, MKR ZERO

MARKER FCTN, MKR SEARCH ON, TARGET, -1, x1

The measurement results show the mixer's 1 dB compression point. By changing the target value, you can easily locate other compression points (for example, 0.5 dB, 3 dB).

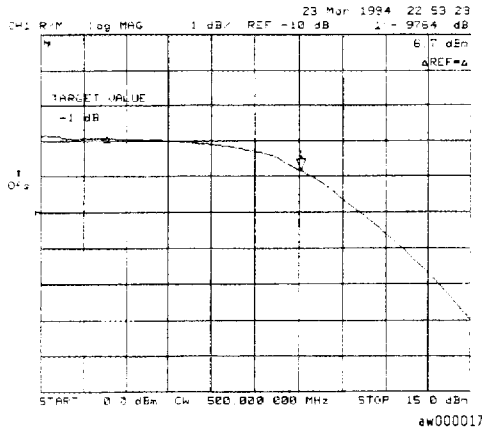

Figure 8-17. Example Swept Power Conversion Compression Measurement

Optional: For information on removing systematic frequency response errors, and on performing a source power meter calibration, refer to “Power Meter Calibration for Mixer Measurements” on page 8-34.

Isolation Example Measurements

Isolation is the measure of signal leakage in a mixer. Feedthrough is specifically the forward signal leakage to the IF port. High isolation means that the amount of leakage or feedthrough between the mixer's ports is very small. Isolation measurements do not use the frequency offset mode. Figure 8-18 illustrates the signal flow in a mixer.

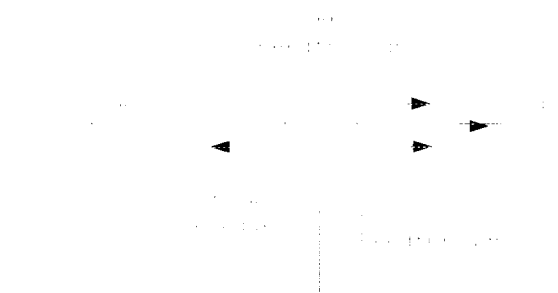

Figure 8-18. Signal Flow in a Mixer

The RF and LO feedthrough signals may appear at the mixer IF output, together with the desired IF signal.

The LO to RF isolation and the LO feedthrough are typically measured with the third port terminated in 50 ohms. Measurement of the RF feedthrough is made as the LO signal is being applied to the mixer.

LO to RF isolation

- 1 Make the connections as shown in Figure 8-19.

CAUTION

To prevent connector damage, use an adapter (HP part number 1250-1462) as a connector saver for R CHANNEL IN.

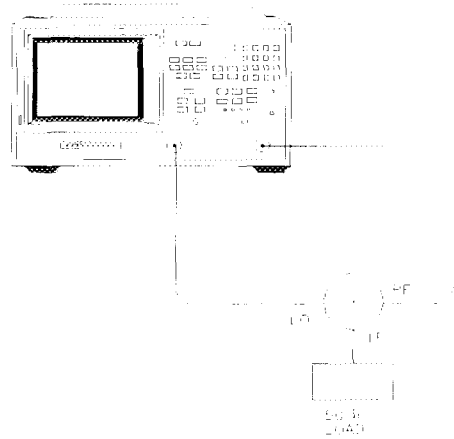

Figure 8-19. Connections for a Mixer Isolation Measurement

- 2 Initialize the analyzer by pressing PRESET.
- 3 To select the analyzer frequency range and source power, press:
START, 10, M/ μ
STOP, 3000, M/ μ
MENU, POWER, 10, x1

This source stimulates the mixer's LO port.

- 4 To select a ratio B/R measurement, press:
MEAS, Trans: FWD S21 (B/R)

- 5 To adjust the display scale, press:
SCALE REF, AUTO SCALE

The measurement results, in Figure 8-20, show the mixer's LO to RF isolation.

Making Mixer Measurements
Isolation Example Measurements

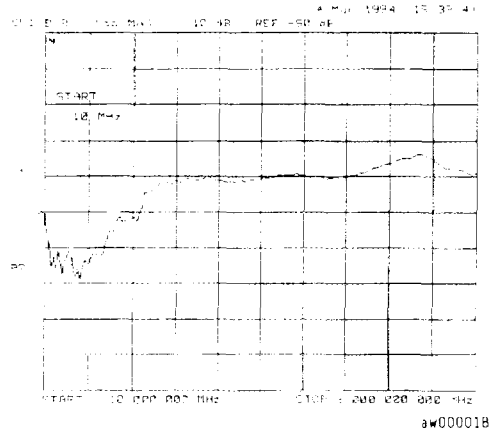

Figure 8-20. Example Mixer LO to RF Isolation Measurement

Optional: For information on removing systematic frequency response errors, refer to Chapter 6, "Optimizing Measurements".

RF Feedthrough

The procedure and equipment configuration necessary for this measurement are very similar to those above, with the addition of an external source to drive the mixer's LO port, as we measure the mixer's RF feedthrough. RF feedthrough measurements do not use the frequency offset mode.

- 1 Select the CW LO frequency and source power from the front panel of the external source.

CW, 300, MHz
POWER, 10, dBm

NOTE

Isolation is dependent on LO power level and frequency. To ensure good test results, you should choose these parameters as close to actual operating conditions as possible.

- 2 Make the connections as shown in Figure 8-21.

CAUTION

To prevent connector damage, use an adapter (HP part number 1250-1462) as a connector saver for R CHANNEL IN.

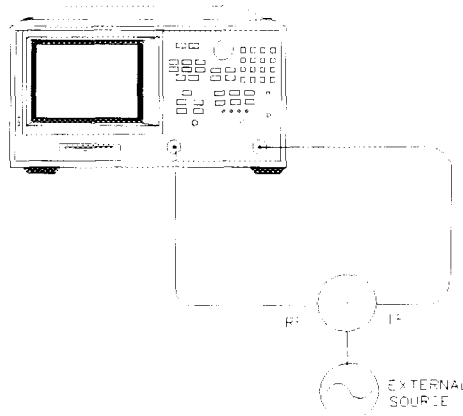

pg8114d

Figure 8-21. Connections for a Mixer RF Feedthrough Measurement

- 3 Initialize the analyzer by pressing PRESET.

Isolation Example Measurements

- 4 To select the analyzer's frequency range and source power, press:

START, 10, M/ μ
STOP, 3000, M/ μ
MENU, POWER, 0, x1

This signal stimulates the mixer's RF port.

- 5 To select a ratio measurement, press:

MEAS, *Trans: FWD S21 (B/R)*

- 6 Connect the external LO source to the mixer's LO port.

- 7 The measurement results, in Figure 8-22, show the mixer's RF feedthrough.

NOTE

You may see spurious responses on the analyzer trace due to interference caused by LO to IF leakage in the mixer. This can be reduced with averaging or by reducing the IF bandwidth.

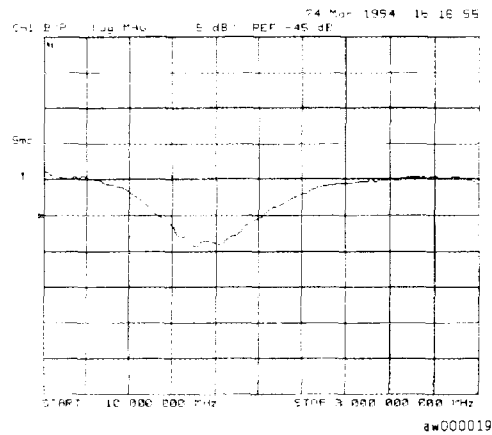

Figure 8-22. Example Mixer RF Feedthrough Measurement

You can measure the IF to RF isolation in a similar manner, but with the following exceptions:

- use the analyzer source as the IF signal drive
- use an external LO source to drive the LO port
- view the leakage signal at the RF port

Optional: For information on removing systematic frequency response errors, refer to Chapter 6, "Optimizing Measurements".

Power Meter Calibration for Mixer Measurements

Mixer transmission measurements are generally configured as follows:

$$(measured\ output\ power) / (set\ input\ power)$$

For this reason, if you accurately control the set input power, you can significantly improve measurement accuracy. You can use power meter correction to correct for power offsets, losses, and flatness variations, occurring between the analyzer source and the input to the mixer under test.

- 1** Set the LO source to the desired CW frequency (1000 MHz) and power level (13 dBm).
- 2** Select the HP 8702D as the system controller by pressing:
LOCAL, SYSTEM CONTROLLER
- 3** Set the power meter's address by pressing:
SET ADDRESSES, ADDRESS: P MTR/HPIB, ##, x1
- 4** Select the appropriate power meter by pressing *POWER METER* until the correct model number is displayed (HP 436A or HP 438A/437).
- 5** Enter the correction factors, as listed on the power sensor.
- 6** From the front panel of the HP 8702D, set the desired receiver frequency and source output power, by pressing:
SYSTEM, INSTRUMENT MODE, FREQ OFFS MENU, FREQ OFFS ON
START, 100, M/μ
STOP, 350, M/μ
MENU, POWER, 0, x1
- 7** Connect the measurement equipment as shown in Figure 8-23.

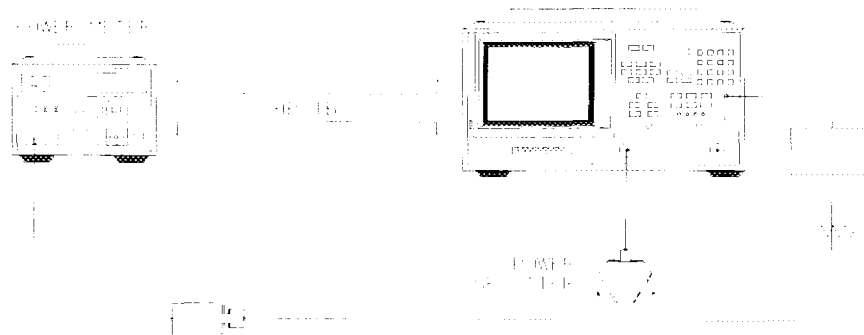

FIGURE 8-23. CONNECTIONS FOR R-C

page 171

Figure 8-23. Connections for R-channel and Source Calibration

- 8 To perform a one sweep power meter calibration over the IF frequency range at 0 dBm, press:

CAL, PWRMTR CAL, ONE SWEEP, 0, x1, TAKE CAL SWEEP

NOTE

Because the power meter calibration is rather slow, you may want to reduce the number of points before pressing *TAKE CAL SWEEP*. After the power meter calibration is finished, return the number of points to its original value and the HP 8702D will automatically interpolate this calibration.

- 9 To calibrate the R-channel over the IF range, press:

*MEAS, INPUT PORTS, R
CAL, CALIBRATE MENU, RESPONSE, THRU, DONE RESPONSE*

- 10 To set the frequency offset mode LO frequency from the analyzer, press:

*SYSTEM, INSTRUMENT MODE, FREQ OFFS MENU, LO MENU, FREQUENCY: CW, 1000, M/ μ ,
POWER: FIXED, 13, x1, RETURN*

- 11 To select the converter type and a high-side LO measurement configuration, press:

DOWN CONVERTER, RF < LO

- 12 To view the measurement trace, press:

VIEW MEASURE

Power Meter Calibration for Mixer Measurements

- 13** Make the connections as shown in Figure 8-24, for the one-sweep power meter calibration.

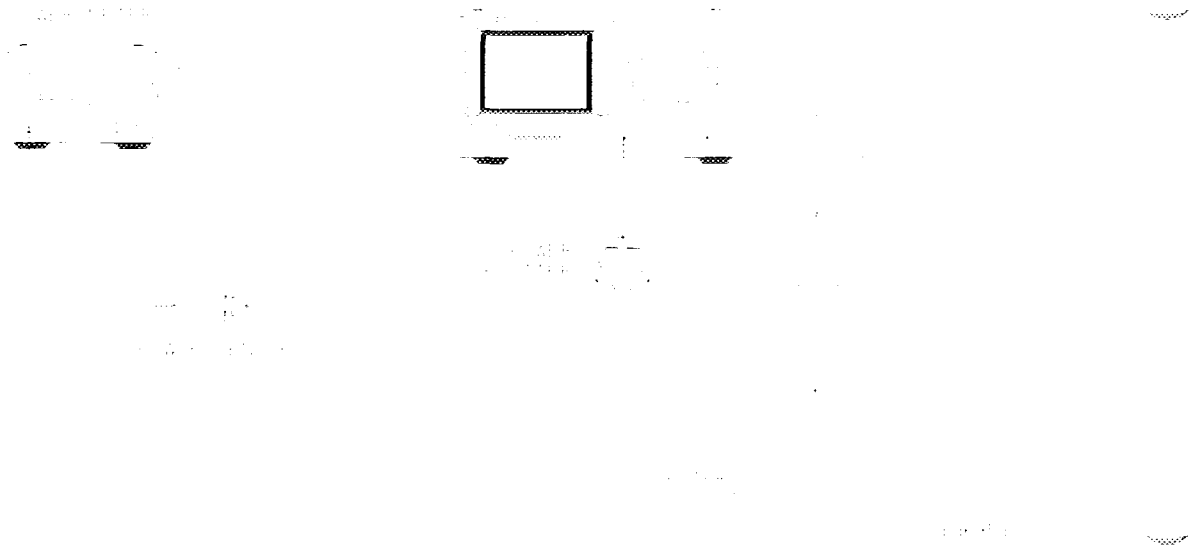

Figure 8-24. Connections for a One-Sweep Power Meter Calibration for Mixer Measurements

- 14** To perform a one-sweep power meter calibration over the RF frequency range, press:

CAL, ONE SWEEP, CAL POWER, 0, x1, TAKE CAL SWEEP

The HP 8702D is now displaying the conversion loss of the mixer, calibrated with power meter accuracy.

Saving Data, States, and the Display

Saving Data, States, and the Display

This chapter explains how to save instrument states, measurement data, and pictures of the display. Saved data and instrument states can be recalled at a later time. You can save these items to the following places:

- Internal memory
- Front panel disk drive
- External HP-IB disk drive

The instrument's internal memory can only store instrument states and memory traces. It *cannot* hold pictures of the display.

What are instrument states?

Instrument states are files which describe the instrument's settings. You recall them to restore the instrument to settings previously made. It provides you with a quick method of preparing the HP 8702D for measurements that you repeat often.

If you are using a DIN keyboard

Cycle the ac power to the analyzer. The keyboard must be connected to the analyzer before you switch on the power.

Internal memory is retained by battery power

When the ac line power is switched off, the internal non-volatile memory is retained by a battery. The data retention time with the 3 V, 1.2 Ah battery is as follows:

Temperature at 70°C	208 days (0.57 year)
Temperature at 40°C	1036 days (2.8 years)
Temperature at 25°C	10 years typical

What you'll find in this chapter

- Saving Instrument States 9-4
- Saving Measurement Data 9-7
- Saving the Display to a File 9-10
- Formatting Disks 9-11
- If You Have Problems with Disk Storage 9-12

Saving Instrument States

You can save instrument states in the instrument's internal memory or on an external disk. When instrument states are saved to internal memory, they are placed in a register. Instrument states contain the following data:

- error-corrections on channels 1 and 2
- displayed memory trace
- print/plot definitions
- frequency range
- number of points
- sweep time
- output power
- sweep type
- measurement parameter

The number of available registers depends on the size of associated error-correction sets, and memory traces. The default registers names are REG1 through REG31. When you save instrument states to a disk inserted into the front-panel disk drive, the default filenames used are FILE00 through FILE31.

If you have saved enough files that you have used all the default names (for disk files, or for memory files), you must do one of the following in order to save more instrument states:

- use another disk
- rename an existing file to make a default name available
- re-save a file/register
- delete an existing file/register

To save an instrument state

1 Press *SAVE/RECALL*, *SELECT DISK* and select one of the storage devices:

- *INTERNAL MEMORY*
- *INTERNAL DISK*
- *EXTERNAL DISK*

2 Press *SAVE/RECALL*, *SAVE STATE*.

The analyzer saves the state in the next available register, if you are saving to internal memory, or saves the state to disk.

To delete an instrument state

1 Press *SAVE/RECALL*, *SELECT DISK*.

2 Choose from the following storage devices:

- *INTERNAL MEMORY*
- *INTERNAL DISK*
- *EXTERNAL DISK*

3 Press *RETURN*.

4 Press ↓ (down arrow) repeatedly until the name of the file that you want to delete is highlighted.

5 Press *FILE UTILITIES*, *DELETE FILE*, *YES*.

To delete all instrument state files, press *FILE UTILITIES*, *DELETE ALL FILES*, *YES*.

To rename an instrument state file

1 Press *SAVE/RECALL*, *SELECT DISK*.

Saving Instrument States

- 2 Choose from the following storage devices:
 - *INTERNAL MEMORY*
 - *INTERNAL DISK*
 - *EXTERNAL DISK*
 - 3 Press ↓ repeatedly until the name of the file that you want to rename is highlighted.
 - 4 Press *RETURN, FILE UTILITIES, RENAME FILE, ERASE TITLE*.
 - 5 Turn the front panel knob to point to each character of the new filename, pressing *SELECT LETTER* when the arrow points to each character. Press *BACKSPACE* if you enter an incorrect character. After you have selected all the characters in the new filename, press *DONE*.
-

To recall an instrument state

- 1 Press *SAVE/RECALL, SELECT DISK*.
- 2 Choose from the following storage devices:
 - *INTERNAL MEMORY*
 - *INTERNAL DISK*
 - *EXTERNAL DISK*
- 3 Press ↓ repeatedly until the name of the file that you want to recall is highlighted.
- 4 Press *RETURN, RECALL STATE*.

Saving Measurement Data

You can save measurement data to internal memory and to a disk file. However, the type of data you can save to these two destinations are different. Only memory traces can be saved to internal memory. The instrument stores data in arrays along the processing flow of numerical data, from IF detection to display. These arrays are points in the flow path where data is accessible, usually via HP-IB. You can choose from three different arrays, which vary in modification flexibility when they are recalled:

- raw data
- data (raw data with error-correction applied)
- format (data processed to the display format)

If you choose to save the raw data array, you will have the most flexibility in modifying the recalled measurement. This is because the raw data array has the least amount of processing associated with it. Conversely, if you choose to save the format array, your modification of the recalled measurement will be limited by all the processes that are associated with that measurement result. However, the format array is appropriate if you want to retrieve data traces that look like the currently displayed data.

Define Save	Modification Flexibility During Recall
Raw Data Array	Most
Data Array	Medium
Format Array	Least

The default filenames for data-only files are DATAnDn for LIF-formatted disks and DATAn.Dn for DOS-formatted disks. The first n is incremented by one each time a file with a default name is added to the directory. The second n is the channel where the measurement was made.

Saving Measurement Data

If the instrument has an active two-port measurement calibration, all four S-parameters will be saved with the measurement results.

The data is stored to disk in IEEE-64 bit real format for LIF disks, and 32 bit PC format for DOS disks. This makes the DOS data files half the size of the LIF files. If you save data only, you cannot recall and display the file contents on the analyzer. This type of data is intended for computer manipulation.

The following block diagram shows the source of each of these data arrays.

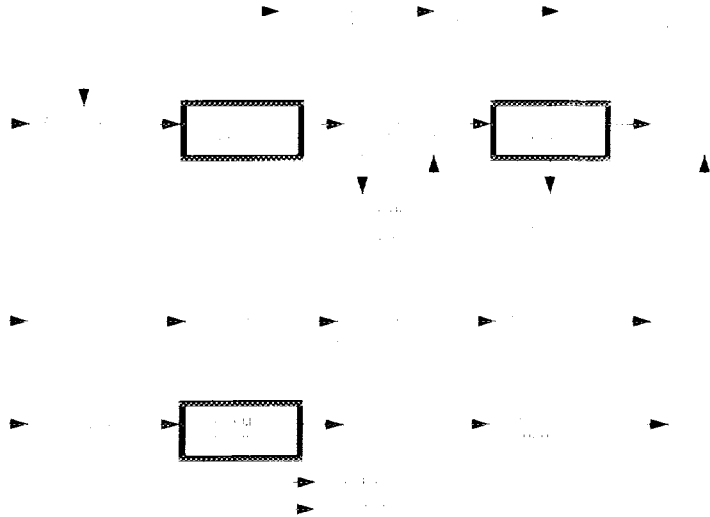

To save a memory trace

- 1** Press *DISPLAY*, *DATA* → *MEMORY*, *DATA* and *MEMORY*.
- 2** *SAVE/RECALL*, *SELECT DISK*, and *INTERNAL MEMORY*.
- 3** Press *RETURN*, *SAVE STATE*.

To save measurement data

- 1** Press *SAVE/RECALL*, *SELECT DISK*.
- 2** Choose one of the following disk drives:
 - *INTERNAL DISK*
 - *EXTERNAL DISK*
 - *CONFIGURE EXT DISK* and then configure as follows:
 - a** Press *SAVE/RECALL*, *DEFINE DISK-SAVE*.
 - b** Define the save by selecting one of the following choices:
 - *DATA ARRAY ON*
 - *RAW ARRAY ON*
 - *FORMAT ARY ON*
 - *GRAPHICS ON*. This selection saves graphics that have been drawn on the display using remote programming techniques.
 - *DATA ONLY ON*
 - c** Choose the type of format you want:
 - Choose *SAVE USING BINARY* for all applications except CITIFILE or CAE applications.
 - Choose *SAVE USING ASCII* for CITIFILE and CAE applications or when you want to import the information into a spreadsheet format.
 - d** Press *RETURN*, *SAVE STATE*.

Saving the Display to a File

A picture of the display can be saved to a graphics file. The file is written on a disk that you insert into the instrument's front-panel disk drive. This file is in the HP-GL graphics format, which some word processors can import directly into documents. If your word processor or graphics program *cannot* import this file format, you can purchase popular software products from your local software vendor that will change the file's format.

Saving the file involves selecting options for plotting a file and then sending the plot to a file rather than to a plotter. (Plot files are in the HP-GL format.) You *cannot* save printer output to a file.

The HP 8702D automatically assigns the first available default filename for the displayed directory. For example, the name PLOT00.LIF (for a DOS format), or PLOT00FP (for LIF format) if there were no previous plot files saved to the disk. The two digit sequence number is incremented by one each time a file with a default name is added to the directory.

To save a picture

- 1 Press LOCAL, *SET ADDRESSES*, *PLOTTER PORT*, *PLTR PORT DISK*.
- 2 Press SAVE/RECALL, *SELECT DISK*, and then *INTERNAL DISK*.
- 3 Press COPY, *PLOT*.

Formatting Disks

To format a disk:

- 1** Press *SAVE/RECALL*, *FILE UTILITIES*, *FORMAT DISK*.
- 2** Choose the type of format you want:
 - *FORMAT:LIF*
 - *FORMAT:DOS*
- 3** Press *FORMAT EXT DISK* or *FORMAT INT DISK*, and then press *YES*.

If You Have Problems with Disk Storage

If you encounter a problem when you are storing files to disk, or the analyzer internal memory, check the following list for possible causes:

- Look in the analyzer display message area. The analyzer may show a message that will identify the problem. Refer to the “Error Messages” chapter in the *HP 8702D Reference* manual if you view a message.
- Make sure that you are *not* using a single-sided floppy disk in the analyzer disk drive.
- Make sure that you are using a formatted disk.
- Make sure that the disk has not been formatted with the LIF-HFS (hierarchical file system) extensions, as the analyzer does *not* support this format.

If You are Using an External Disk Drive

- Make sure that the analyzer is in system controller mode, by pressing LOCAL, SYSTEM CONTROLLER.
- Make sure that you have connected the disk drive to ac power, switched on the power, and connected an HP-IB cable between the disk drive and the analyzer.
- Make sure that the analyzer recognizes the disk drive's HP-IB address, as explained in the *HP 8702D Installation Guide*.
- Make sure that the analyzer recognizes the disk (drive) unit that you selected (0 or 1).
- If the external disk is a hard disk, make sure that the disk volume number is set correctly.
- If the disk drive is an older HP 9122, it may *not* recognize the newer high density disks.
- Substitute the HP-IB cable.
- Substitute the disk drive.

Using Limit Lines

Using Limit Lines

Limit lines allow you to test the shape (frequency and amplitude) of displayed responses. Because limit lines allow you to perform repetitive testing of response shapes, they are ideal for pass/fail testing on production lines. You design, create, save, recall, and edit limit lines using the limit menu accessed from the SYSTEM key.

Limit testing is implemented by creating individual flat, sloping, and single point limit lines on the display. When combined, these lines represent the performance parameters for your device under test.

The three examples in this chapter show you how to create flat, sloping, and single-point limit lines for the same bandpass filter. Using a simple bandpass filter and making an electrical-to-electrical transmission response measurement is an easy method of practicing using these three different types of limit lines.

The bandpass filter used for these examples requires the following instrument settings. You can substitute another device or test if it is more convenient.

Center frequency 134 MHz
Frequency span 50 MHz

When you create and use limit lines, keep in mind that the minimum amplitude value for limit testing is -200 dB.

What you'll find in this chapter

General Information 10-4

Example 1. Creating Flat Limits 10-10

Example 2. Creating Sloping Limits 10-13

Example 3. Creating Single-Point Limits 10-15

General Information

Limit lines and limit testing

You can have limit lines drawn on the display to represent upper and lower limits or device specifications with which to compare the test device. Limits are defined in segments, where each segment is a portion of the stimulus span. Each limit segment has an upper and a lower starting limit value. Three types of segments are available: flat line, sloping line, and single point.

Limits can be defined independently for the two channels, up to 18 segments for each channel. These can be in any combination of the three limit types.

Limit testing compares the measured data with the defined limits, and provides pass or fail information for each measured data point. An out-of-limit test condition is indicated in five ways: with a FAIL message on the screen, with a beep, by blanking of portions of the trace, with an asterisk in tabular listings of data, and with a bit in the HP-IB event-status register B. The HP 8702D has a BNC rear panel output that includes this status.

Limit lines and limit testing can be used simultaneously or independently. If limit lines are on and limit testing is off, the limit lines are shown on the display for visual comparison and adjustment of the measurement trace. However, no pass/fail information is provided. If limit testing is on and limit lines are off, the specified limits are still valid and the pass/fail status is indicated even though the limit lines are not shown on the display.

Limits are entered in tabular form. Limit lines and limit testing can be either on or off while limits are defined. As new limits are entered, the tabular columns on the display are updated, and the limit lines (if on) are modified to the new definitions. The complete limit set can be offset in either stimulus or amplitude value.

Limits are checked only at the actual measured data points. It is possible for a device to be out of specification without a limit test failure indication if the point density is insufficient. Be sure to specify a high enough number of measurement points in the stimulus menu.

Limit lines are displayed only on Cartesian formats. In polar and Smith chart formats, limit testing of one value is available: the value tested depends on the marker mode and is the magnitude or the first value in a complex pair. The message `NO LIMIT LINES DISPLAYED` is shown on the display in polar and Smith chart formats.

The list values feature in the copy menu provides tabular listings to the display or a printer for every measured stimulus value. These include limit line or limit test information if these functions are activated. If limit testing is on, an asterisk is listed next to any measured value that is out of limits. If limit lines are on, and other listed data allows sufficient space, the upper limit and lower limit are listed, together with the margin by which the device data passes or fails the nearest limit.

If limit lines are on, they are plotted with the data on a plot. If limit testing is on, the `PASS` or `FAIL` message is plotted, and the failing portions of the trace that are blanked on the display are also blanked on the plot. If limits are specified, they are saved in memory with an instrument state.

The series of menus for defining limits is accessed from the `SYSTEM` key.

Edit limits menu

This menu is used to specify limits for limit lines or limit testing, and presents a table of limit values on the display. Limits are defined in segments. Each segment is a portion of the stimulus span. Up to 18 limit segments can be specified for each channel. The limit segments do not have to be entered in any particular order: the analyzer automatically sorts them and lists them on the display in increasing order of start stimulus value.

For each segment, the table lists the segment number, the starting stimulus value, upper limit, lower limit, and limit type. The ending stimulus value is the start value of the next segment, or a segment can be terminated with a single point segment. Limit values are entered as upper and lower limits or delta limits and middle value. As new limit segments are defined, the tabular listing is updated, and if limit lines are switched on, they are plotted on the display.

If no limits have been defined, the table of limit values shows the notation `EMPTY`. Limit segments are added to the table using the `ADD` softkey or edited with the `EDIT` softkey, as previously described. The last segment on the list is followed by the notation `END`.

General Information**Edit segment menu**

This menu sets the values of the individual limit segments. The segment to be modified, or a default segment, is selected in the edit limits menu. The stimulus value can be set with the controls in the entry block or with a marker (the marker is activated automatically when this menu is presented). The limit values can be defined as upper and lower limits, or delta limits and middle value. Both an upper limit and a lower limit (or delta limits) must be defined: if only one limit is required for a particular measurement, force the other out of range (for example, +500 dB or -500 dB).

As new values are entered, the tabular listing of limit values is updated.

Segments do not have to be listed in any particular order: the analyzer sorts them automatically in increasing order of start stimulus value when the *DONE* key, in the edit limits menu, is pressed. However, the easiest way to enter a set of limits is to start with the lowest stimulus value and define the segments from left to right of the display, with limit lines turned on as a visual check.

Phase limit values can be specified between +500° and -500°. Limit values above +180° and below -180° are mapped into the range of -180° to +180° to correspond with the range of phase data values.

Offset limits menu This menu allows the complete limit set to be offset in either stimulus value or amplitude value. This is useful for changing the limits to correspond with a change in the test setup, or for device specifications that differ in stimulus or amplitude. It can also be used to move the limit lines away from the data trace temporarily for visual examination of trace detail.

To enter segments

Refer to the following examples in this chapter to learn how to create limit lines:

- Example 1. Creating Flat Limits 10-10
- Example 2. Creating Sloping Limits 10-13
- Example 3. Creating Single-Point Limits 10-15

To edit a segment

- 1 Press *SYSTEM*, *LIMIT MENU*, *LIMIT LINE ON*, *EDIT LIMIT LINE* and then *SEGMENT*.
- 2 To move the pointer symbol (>) on the instrument display to the segment you wish to modify, press: ↑ or ↓ repeatedly, or enter the segment number followed by x1.
- 3 Press *EDIT*, and then modify the desired values. Press *DONE* to enter the changes. For example, to change the upper limit of a limit line, press:
EDIT, *UPPER LIMIT*, -20, x1, *DONE*

To delete limit line segments

- 1 Press *SYSTEM*, *LIMIT MENU*, *LIMIT LINE ON*, and then *EDIT LIMIT LINE* to view the current limit line.
- 2 Move the pointer symbol (>) on the display to the segment you wish to delete, by pressing *SEGMENT*, ↑ or ↓, repeatedly.
- 3 Press *DELETE*.

To offset the limit lines

The limit offset functions allow you to adjust the limit lines to the frequency and output level of your device. For example, you could apply the stimulus offset feature for testing tunable filters. Or, you could apply the amplitude offset feature for testing variable attenuators, or passband ripple in filters with variable loss.

- 1 To offset all of the segments in the limit table by a fixed frequency (for example, 3 MHz), press:

SYSTEM, LIMIT MENU, LIMIT LINE OFFSETS, STIMULUS OFFSET, 3, M/ μ

The instrument beeps and a FAIL notation appears on the instrument display, as shown in Figure 10-1.

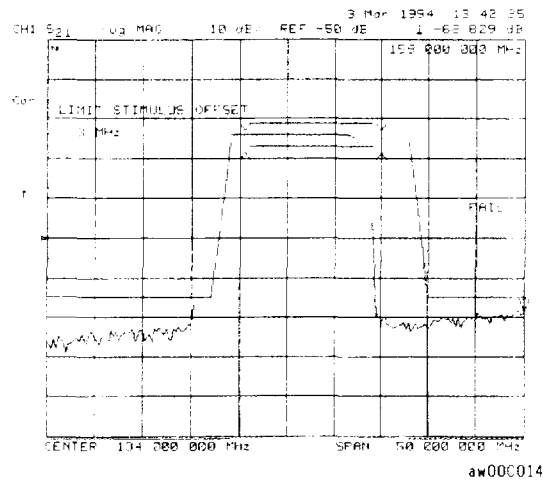

Figure 10-1. Example Stimulus Offset of Limit Lines

- 2 To return to 0 Hz offset, press:

STIMULUS OFFSET, 0, x1

- 3 To offset all of the segments in the limit table by a fixed amplitude, press:

AMPLITUDE OFFSET, 5, x1

The instrument beeps and a FAIL notation appears on the instrument display, as shown in Figure 10-1.

- 4 To return to 0 dB offset, press:

AMPLITUDE OFFSET, 0, x1

To turn on limit testing

- 1 Press *SYSTEM, LIMIT MENU, LIMIT LINE ON*, and then *EDIT LIMIT LINE* to view the current limit line.
- 2 To verify that each segment in your limits table is correct, review the entries by pressing *SEGMENT, ↑*, and *↓*.
- 3 To activate the limit test and the beep fail indicator, press:

SYSTEM, LIMIT MENU, LIMIT TEST ON, and then *BEEP FAIL ON*.

The limit test results appear on the right side on the instrument display. The instrument indicates whether the filter passes or fails the defined limit test:

- The instrument beeps if the limit test fails.
- The instrument alternates a red trace where the measurement trace is out of limits.
- A TTL signal on the rear panel BNC connector LIMIT TEST provides a pass/fail (5 V/0 V) indication of the limit test results.

Example 1. Creating Flat Limits

In this example procedure, the following flat limit line values are set:

Frequency Range	Power Range
127 MHz to 140 MHz	-27 dB to -21 dB
100 MHz to 123 MHz	-200 dB to -65 dB
146 MHz to 160 MHz	-200 dB to -65 dB

- 1** To access the limits menu and activate the limit lines, press:

SYSTEM, LIMIT MENU, LIMIT LINE ON, EDIT LIMIT LINE, CLEAR LIST, YES

- 2** To create a new limit line, press: *ADD*

The instrument generates a new segment that appears on the center of the display.

- 3** To specify the limit's stimulus value, test limits (upper and lower), and the limit type, press:

STIMULUS VALUE, 127, M/μ
UPPER LIMIT, -21, x1
LOWER LIMIT, -27, x1
DONE

You could also set the upper and lower limits by using the *MIDDLE VALUE* and *DELTA LIMITS* keys. To use these keys for the entry, press:

MIDDLE VALUE, -24, x1, DELTA LIMITS, 3, x1

This would correspond to a test specification of -24 ± 3 dB.

- 4** To define the limit as a flat line, press:

LIMIT TYPE, FLAT LINE, RETURN

5 To terminate the flat line segment by establishing a single point limit, press:

ADD, STIMULUS VALUE, 140, M/μ, DONE, LIMIT TYPE, SINGLE POINT, RETURN

Figure 10-2 shows the flat limit lines that you have just created with the following parameters:

- stimulus from 127 MHz to 140 MHz
- upper limit of -21 dB
- lower limit of -27 dB

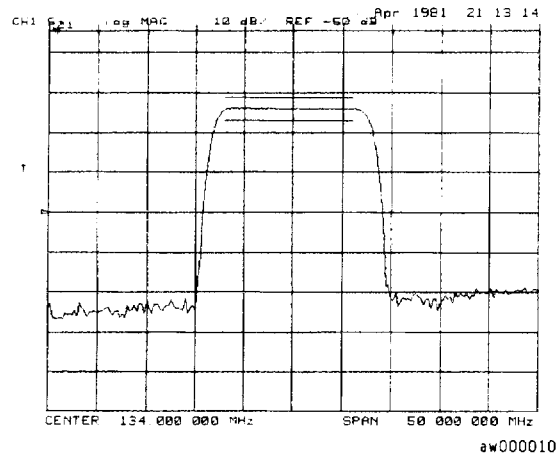

Figure 10-2. Example Flat Limit Line

6 To create a limit line that tests the low side of the filter, press:

*ADD
STIMULUS VALUE, 100, M/μ
UPPER LIMIT, -65, x1
LOWER LIMIT, -200, x1
DONE
LIMIT TYPE, FLAT LINE, RETURN
ADD
STIMULUS VALUE, 123, M/μ
DONE
LIMIT TYPE, SINGLE POINT, RETURN*

Example 1. Creating Flat Limits

7 To create a limit line that tests the high side of the bandpass filter, press:

```
ADD  
STIMULUS VALUE, 146, M/μ  
UPPER LIMIT, -65, x1  
LOWER LIMIT, -200, x1  
DONE  
LIMIT TYPE, FLAT LINE, RETURN  
ADD  
STIMULUS VALUE, 160, M/μ  
DONE  
LIMIT TYPE, SINGLE POINT, RETURN
```

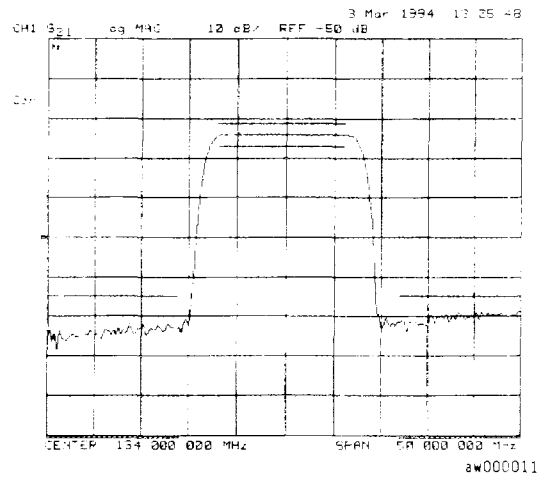

Figure 10-3. Example Flat Limit Lines

Example 2. Creating Sloping Limits

This example procedure shows you how to make limits that test the shape factor of a SAW filter. The following limits are set:

Frequency Range	Power Range
123 MHz to 125 MHz	-65 dB to -26 dB
144 MHz to 146 MHz	-26 dB to -65 dB

- 1 To access the limits menu and activate the limit lines, press:
SYSTEM, LIMIT MENU, LIMIT LINE ON, EDIT LIMIT LINE, CLEAR LIST, YES
- 2 To establish the start frequency and limits for a sloping limit line that tests the low side of the filter, press:
ADD
STIMULUS VALUE, 123, M/μ
UPPER LIMIT, -65, x1
LOWER LIMIT, -200, x1
DONE
LIMIT TYPE, SLOPING LINE, RETURN
- 3 To terminate the lines and create a sloping limit line, press:
ADD
STIMULUS VALUE, 125, M/μ
UPPER LIMIT, -26, x1
LOWER LIMIT, -200, x1
DONE
LIMIT TYPE, SINGLE POINT, RETURN

Example 2. Creating Sloping Limits

- 4 To establish the start frequency and limits for a sloping limit line that tests the high side of the filter, press:

```
ADD  
STIMULUS VALUE, 144, M/μ  
UPPER LIMIT, -26, x1  
LOWER LIMIT, -200, x1  
DONE  
LIMIT TYPE, SLOPING LINE, RETURN
```

- 5 To terminate the lines and create a sloping limit line, press:

```
ADD  
STIMULUS VALUE, 146, M/μ  
UPPER LIMIT, -65, x1  
LOWER LIMIT, -200, x1  
DONE  
LIMIT TYPE, SINGLE POINT, RETURN
```

You could use this type of limit to test the shape factor of a filter.

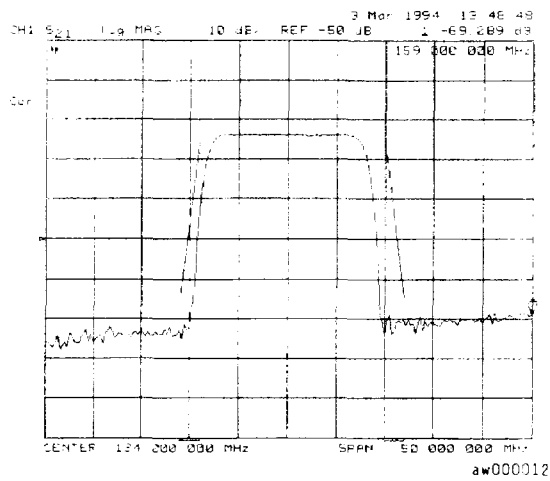

Figure 10-4. Sloping Limit Lines

Example 3. Creating Single-Point Limits

In this example procedure, the following limits are set:

Frequency Range	Power Range
141 MHz	-23 dB to -28.5 dB
126.5 MHz	-23 dB to -28.5 dB

- 1 To access the limits menu and activate the limit lines, press:
SYSTEM, LIMIT MENU, LIMIT LINE ON, EDIT LIMIT LINE, CLEAR LIST, YES
- 2 To designate a single point limit line, as shown in Figure 10-5, you must define two pointers;
 - downward pointing, indicating the upper test limit
 - upward pointing, indicating the lower test limit

Press:

```
ADD
STIMULUS VALUE, 141, M/μ
UPPER LIMIT, -23, x1
LOWER LIMIT, -28.5, x1
DONE
LIMIT TYPE, SINGLE POINT
RETURN
ADD
STIMULUS VALUE, 126.5, M/μ
UPPER LIMIT, -23, x1
LOWER LIMIT, -28.5, x1
DONE
LIMIT TYPE, SINGLE POINT
RETURN
```

Example 3. Creating Single-Point Limits

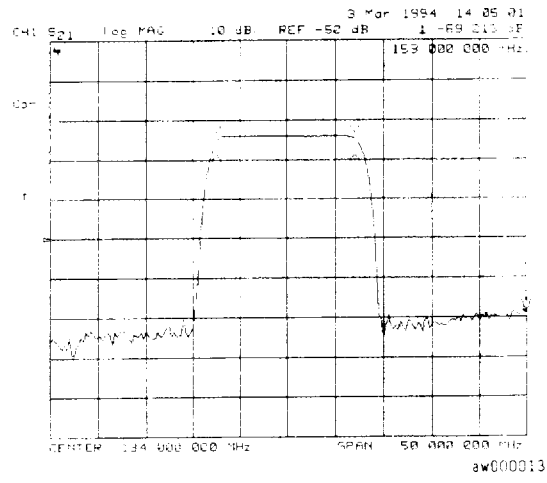

Figure 10-5. Example Single Points Limit Line

Creating Sequences

Creating Sequences

Test sequences allow you to automate repetitive tasks. As you make the measurement, the analyzer memorizes the keystrokes. Later you can repeat the entire sequence by pressing a single key. Because the sequence is defined with normal measurement keystrokes, you do not need additional programming expertise. Subroutines and limited decision-making increases the flexibility of sequences. In addition, the GPIO outputs can be controlled in a sequence, and the GPIO inputs can be tested in a sequence for conditional branching.

The sequence function allows you to create, title, save, and execute up to six independent sequences internally.

You can also save sequences to disk and transfer them between the analyzer and an external computer controller.

The following procedures are based on an actual measurement example, that show you how to do the following:

- create a sequence
- title a sequence
- edit a sequence
- clear a sequence
- store a sequence
- load a sequence
- purge a sequence

What you'll find in this chapter

General Information 11-4
Creating and Editing Sequences 11-12
Running Sequences 11-21
Saving and Printing 11-22

General Information

Test sequencing is an analyzer function that allows you to automate repetitive tasks. You can create a sequence as you are making a measurement. Then when you want to make that same measurement again, you can recall the sequence and the analyzer will repeat the previous keystrokes.

The following is list of some of the key test sequencing features on the HP 8702D analyzer:

- Limited decision-making functions increase the versatility of the test sequences you create by allowing you to jump from one sequence to another.
- A *GOSUB SEQUENCE* function that allows you to call other sequences as sub-routines.
- You can create, title, save, and execute up to six sequences.
- You can save your sequences to a disk using the internal disk drive.
- You can use the parallel port as a general purpose input/output (GPIO) bus to read five TTL input bits in a decision making function, and send eight TTL output bits to control a peripheral.

NOTE

Product Note 8753-3 *RF Component Measurements - Applications of the Test Sequence Function* provides practical applications examples for test sequencing. This note was written for the HP 8753B, but also applies to the HP 8702D.

In-depth sequencing information

Features that operate differently when executed in a sequence

The analyzer does *not* allow you to use the following keys in a sequence:

- ↑, ↓ keys
- PRESET key
- ← key

Commands that sequencing completes before the next sequence command begins

The analyzer completes all operations related to the following commands before continuing with another sequence command:

- single sweep
- number of groups
- auto scale
- marker search
- marker function
- data → memory
- recall or save (internal or external)
- copy list values and operating parameters
- CHAN 1, CHAN 2, Wait 0

*Wait 0 is the special sequencing function *WAIT* *x* with a zero entered for the delay value.

Commands that require a clean sweep

Many front panel commands disrupt the sweep in progress, for example, changing the channel or measurement type. When the analyzer does execute a disruptive command in a sequence, some instrument functions are inhibited until a complete sweep is taken. This applies to the following functions:

- auto scale
- data → memory

Forward stepping in edit mode

In the sequence modify mode, you can step through the selected sequence list, where the analyzer executes each step.

General Information**Titles**

A title may contain non-printable or special ASCII characters if you download it from an external controller. A non-printable character is represented on the display as π .

Sequence size

A sequence may contain up to 2 kilobytes of instructions. Typically, this is around 200 sequence command lines. To estimate a sequence's size (in kilobytes), use the following guidelines.

Type of Command	Size in Bytes
Typical command	2
Title string character	1
Active entry command	1 per digit

Embedding the value of the loop counter in a title

You can append a sequentially increasing or decreasing numeric value to the title of stored data by placing a `DISPLAY`, `MORE`, `TITLE`, `MORE`, `LOOP COUNTER` command after the title string. (You must limit the title to three characters if you will use it as a disk file name. The three-character title and five-digit loop counter number reach the eight-character limit for disk file names.) This feature is useful in data logging applications.

Gosub sequence command

The "gosub sequence" feature allows the sequence to branch off to another sequence, then return to the original sequence. For example, you could perform an amplifier measurement in the following manner:

- 1** Create sequence 1 for the specific purpose of performing the gain measurement and printing the results. This sequence will act as a sub-routine.
- 2** Create sequence 2 to set up a series of different input power levels for the amplifier gain measurements. In between each power level setting, call sequence 1 as a sub-routine by pressing `GOSUB SEQUENCE, SEQUENCE 1`. Now, sequence 2 will print the measurement results for each input power level applied to the amplifier.

The GPIO mode

The instrument's parallel port can be used in two different modes. By pressing LOCAL and then toggling the PARALLEL [] softkey, you can select either the [COPY] mode or the [GPIO] mode.

The GPIO mode turns the parallel port into a "general purpose input/output" port. In this mode, the port can be connected to test fixtures, power supplies, and other peripheral equipment that the analyzer can interact with through test sequencing.

TTL output for controlling peripherals

Eight TTL-compatible output lines can be used for controlling equipment connected to the parallel port. By pressing SEQ, TTL I/O you will access the softkeys (listed below) that control the individual output bits. Refer to Figure 11-1 for output bus pin locations. The pin assignments are as follows:

- Pin 1 is data strobe.
- Pin 16 selects the printer.
- Pin 17 resets the printer.
- Pins 18-25 are all ground.

The electrical specifications are as follows:

- TTL High 2.7 volts and current is 20 μ A
- TTL Low 0.4 volts and current is 0.2 μ A
- PARALLEL OUT ALL inputs a number (0 to 255) in base 10 and outputs it to the bus as binary.
- SET BIT sets a single bit (0 – 7) to high on the output bus.
- CLEAR BIT sets a single bit (0 – 7) to low on the output bus.

General Information

TTL input decision making

Five TTL-compatible input lines can be used for decision making in test sequencing. For example, if a test fixture is connected to the parallel port and has a micro switch that needs to be activated in order to proceed with a measurement, you can construct your test sequence so that it checks the TTL state of the input line corresponding to the switch. Depending on whether the line is high or low, you can jump to another sequence. To access these decision making functions, press SEQ, *TTL I/O*. Refer to Figure 11-1 for input bus pin locations.

PARALL IN BIT

NUMBER selects the single bit (0 – 4) that the sequence will be looking for.

PARALL IN IF BIT H jumps to another sequence if the single input bit you selected is in a high state.

PARALL IN IF BIT L jumps to another sequence if the single input bit you selected is in a low state.

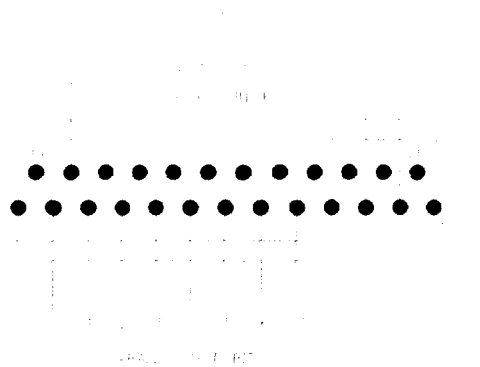

Figure 11-1. Parallel Port Input and Output Bus Pin Locations in GPIO mode

Decision making functions

Decision making functions are explained in more detail below. These functions check a condition and jump to a specified sequence if the condition is true. The sequence called must be in memory. A sequence call is a one-way jump. A sequence can jump to itself, or to any of the other five sequences currently in memory. Use of these features is explained under the specific softkey descriptions.

Decision making functions jump to a softkey location, not to a specific sequence title

Limit test, loop counter, and do sequence commands jump to any sequence residing in the specified sequence position (1 through 6). These commands do not jump to a specific sequence title. Whatever sequence is in the selected softkey position will run when these commands are executed.

Having a sequence jump to itself

A decision making command can jump to the sequence it is in. When this occurs, the sequence starts over and all commands in the sequence are repeated. This is used a great deal in conjunction with loop counter commands. See the loop counter description below.

TTL input decision making

TTL input from a peripheral connected to the parallel port (in the GPIO mode) can be used in a decision making function. Refer to "TTL output for controlling peripherals" on page 11-7 for more information.

Limit test decision making

A sequence can jump to another sequence or start over depending on the result of a limit test. When entered into a sequence, the *IF LIMIT TEST PASS* and *IF LIMIT TEST FAIL* commands require you to enter the destination sequence.

Loop counter/loop counter decision making

The analyzer has a numeric register called a loop counter. The value of this register can be set by a sequence, and it can be incremented or decremented each time a sequence repeats itself. The decision making commands *IF LOOP COUNTER = 0* and *IF LOOP COUNTER <> 0* jump to another sequence if the stated condition is true. When entered into the sequence, these commands require you to enter the destination sequence. Either command can jump to another sequence, or restart the current sequence.

As explained later, the loop counter value can be appended to a title. This allows customized titles for data printouts or for data files saved to disk.

Autostarting sequences

You can define a sequence to run automatically when you apply power to the analyzer. To make an autostarting sequence, create a sequence in position six and title it "AUTO". To stop an autostarting sequence, press LOCAL. To stop an autostarting sequence from engaging at power on, you must clear it from memory or rename it.

HP-GL considerations

Entering HP-GL commands

The analyzer allows you to use HP-GL (Hewlett-Packard Graphics Language) to customize messages or illustrations on the display of the analyzer. To use HP-GL, the instrument must be in system controller mode.

HP-GL commands should be entered into a title string using the *DISPLAY*, *MORE*, *TITLE* and character selection menu.

The *TITLE TO PERIPHERAL* sequencing command sends the HP-GL command string to the analyzer's HP-GL address. The address of the analyzer's HP-GL graphics interface is always offset from the instrument's HP-IB address by 1:

- If the current instrument address is an even number.

HP-GL address = instrument address + 1.

- If the current instrument address is an odd number.

HP-GL address = instrument address - 1.

Special commands

Two HP-GL commands require special consideration when used in local operation or in sequencing. These are explained below:

Plot absolute (HP-GL command: PA)

The syntax for this command is *PA**x*, *y* (where *x* and *y* are screen location coordinates separated by a comma).

Label (HP-GL command: LB)

The syntax for this command is *LB*[*text*] [*etx*]. The label command will print ASCII characters until the *etx* command is seen. The *etx* is the ASCII value 3 (not the ASCII character 3).

The analyzer title function does not have the ASCII value 3, so the instrument allows the *LB* command to be terminated with the *END OF LABEL* command (accessed by pressing *DISPLAY*, *MORE*, *TITLE*, *MORE*, *END OF LABEL*).

Entering sequences using HP-IB

You can create a sequence in a computer controller using HP-IB codes and enter it into the analyzer over HP-IB. This method replaces the keystrokes with HP-IB commands. The following is a procedure for entering a sequence over HP-IB:

- 1** Send the HP-IB command `NEWSEQx` (where `x` is a number from 1 to 6).
- 2** Send the HP-IB commands for the measurement.
- 3** Terminate with the HP-IB command `DONM` (done modify).

Reading sequences using HP-IB

An external controller can read the commands in any sequence (in HP-IB command format). Send the following command to the analyzer: `OUTPSEQx` (where `x` is a number from 1 to 6).

Allocate an adequate amount of string variable space in the external controller and execute an `ENTER` statement.

Creating and Editing Sequences

This section provides instructions for creating and editing sequences. Three of these procedures give practical examples including cascading multiple sequences, loop counters, and limit testing. Because individual sequences can not be longer than 200 lines, you can link sequences into a larger program. This is known as cascading sequences.

To write a sequence

- 1** To enter the sequence creation mode, press: *SEQ, NEW SEQ/MODIFY SEQ.*

As shown in Figure 11-2, a list of instructions appear on the analyzer display to help you create or edit a sequence.

- 2** To select a position in which to store your sequences, press:

SEQUENCE 1 SEQ1

This choice selects sequence position #1. The default title is SEQ1 for this sequence.

Refer to "To change a sequence title" on page 11-22 for information on how to modify a sequence title.

- 3** To create a sequence, enter the parameters for the measurement that you wish to make. For this example, a SAW filter measurement is set up with the following parameters:

SAVE/RECALL, RECALL STATE
MEAS, Trans: E/E S21 FWD
FORMAT, LOG MAG
CENTER, 134, M/μ
SPAN, 50, M/μ
SCALE REF, AUTO SCALE

The above keystrokes will create a displayed list as shown:

```
Start of Sequence
RECALL PRST STATE
Trans: E/E
LOG MAG
CENTER
    134 M/u
SPAN
    50 M/u
SCALE/DIV
AUTO SCALE
```

4 To complete the sequence creation, press:

SEQ, *DONE SEQ MODIFY*

CAUTION

When you create a sequence, the analyzer stores it in volatile memory where it will be lost if you switch off the instrument power (except for sequence #6 which is stored in the analyzer non-volatile memory). However, you may store sequences to a floppy disk.

```
TEST EQUATE ID
MODIFY
To INSERT - Add function inserted after cursor
To DELETE - BACKSPACE deletes one at cursor
To MOVE - Use ARROW keys or knob. ARROW updates the function after the
          cursor and moves left up - ARROW down only moves left down
To END - Press DONE SEQ MODIFY in SEQUENCE MENU
RUN
To START - Press DO SEQUENCE in SEQUENCE MENU
KEYS - All front panel keys except LOCAL are locked out until
       sequence stops.
To STOP - Press LOCAL to stop a running sequence.
To PAUSE - Press CONTINUE SEQUENCE in SEQUENCE MENU to restart a
          paused sequence.
Only sequence will saved when instrument is turned off
Select a softkey to start modifying a sequence -
```

pg097c

Figure 11-2. Test Sequencing Help Instructions

To delete commands

- 1** To enter the creation/editing mode, press:
SEQ, NEW SEQ/MODIFY SEQ
- 2** To select the particular sequence you wish to modify (sequence 1 in this example), press:
SEQUENCE 1 SEQ1
- 3** To move the cursor to the command that you wish to delete, press:
↑ or ↓
 - If you use the ↑ key to move the cursor through the list of commands, the commands are actually performed when the cursor points to them. This feature allows the sequence to be tested one command at a time.
 - If you wish to scroll through the sequence without executing each line as you do so, you can press the ↓ key and scroll through the command list backwards.
- 4** To delete the selected command, press:
← (backspace key)
- 5** Press *SEQ, DONE SEQ MODIFY* to exit the modify (edit) mode.

To insert a command

- 1** To enter the creation/editing mode, press:
SEQ, NEW SEQ/MODIFY SEQ
- 2** To select the particular sequence you wish to modify (sequence 1 in this example), press:
SEQUENCE 1 SEQ1
- 3** To insert a command, move the cursor to the line immediately above the line where you want to insert a new command, by pressing:
↑ or ↓
 - If you use the ↑ key to move the cursor through the list of commands, the commands are actually performed when the cursor points to them. This fea-

ture allows the sequence to be tested one command at a time.

- If you wish to scroll through the sequence without executing each line as you do so, you can press the ↓ key and scroll through the command list backwards.
- 4 To enter the new command, press the corresponding front panel keys. For example, if you want to activate the averaging function, press:
AVG, AVERAGING ON
 - 5 Press *SEQ, DONE SEQ MODIFY* to exit the modify (edit) mode.

To modify a command

- 1 To enter the creation/editing mode, press:
PRESET, SEQ, NEW SEQ/MODIFY SEQ
- 2 To select the particular sequence you wish to modify, (sequence 1 in this example), press:

SEQUENCE 1 SEQ1

In the following example, notice that for longer sequences, only a portion of the list can appear on the screen at one time.

```
Start of Sequence
RECALL PRST STATE
Trans: E/E
LOG MAG
CENTER
134 M/u
SPAN
50 M/u
SCALE/DIV
AUTO SCALE
```

- 3 To change a command (for example, the span value from 50 MHz to 75 MHz) move the cursor (→) next to the command that you wish to modify, press:

↑ or ↓

- If you use the ↑ key to move the cursor through the list of commands, the commands are actually performed when the cursor points to them. This feature allows the sequence to be tested one command at a time.
- If you wish to scroll through the sequence without executing each line as you do so, you can press the ↓ key and scroll through the command list backwards.

Creating and Editing Sequences

- 4 To delete the current command (for example, span value), press:
← (backspace key)
- 5 To insert a new value (for example, 75 MHz), press:
75, M/μ
- 6 Press *SEQ, DONE SEQ MODIFY* to exit the modify (edit) mode.

To create a link

By cascading sequences, you can create sub-programs for a larger sequence. You can also cascade sequences to extend the length of sequences to greater than 200 lines. In this example, you are shown two sequences that have been cascaded. You can do this by having the last command in sequence 1 call sequence position 2, regardless of the sequence title.

- 1 To create the example multiple sequence, press:

```
SEQ, NEW SEQ/MODIFY SEQ, SEQUENCE 1 SEQ1
CENTER, 134, M/μ
SPAN, 50, M/μ
SEQ, DO SEQUENCE
SEQUENCE 2 SEQ2, SEQ DONE SEQ MODIFY
NEW SEQ/MODIFY SEQ, SEQUENCE 2 SEQ2
MEAS, Trans: E/E S21 FWD
FORMAT, LOG MAG
SCALE REF, AUTO SCALE
SEQ, DONE SEQ MODIFY
```

The following sequences will be created:

```
SEQUENCE SEQ1
Start of Sequence
CENTER
    134 M/u
SPAN
    50 M/u
DO SEQUENCE
SEQUENCE 2
SEQUENCE SEQ2
Start of Sequence
Trans: E/E S21 FWD
LOG MAG
SCALE/DIV
AUTO SCALE
```

You can extend this process of calling the next sequence from the last line of the present sequence to 6 internal sequences, or an unlimited number of externally stored sequences.

- 2 To run both sequences, press:

PRESET, *SEQUENCE 1 SEQ1*

To build a loop counter

This example shows you the basic steps necessary for constructing a looping structure within a sequence. A typical application of this loop counter structure is for repeating a specific measurement as you step through a series of CW frequencies or dc bias levels.

- 1 To create a sequence that will set the initial value of the loop counter, and call the sequence that you want to repeat, press:

SEQ, *NEW SEQ/MODIFY SEQ, SEQUENCE 1 SEQ1, SPECIAL FUNCTIONS, DECISION MAKING, LOOP COUNTER, 10, x1*
SEQ, *DO SEQUENCE, SEQUENCE 2 SEQ2, DONE, SEQ MODIFY*

This will create a displayed list as shown:

```
SEQUENCE LOOP 1
Start of Sequence
LOOP COUNTER
  10x1
DO SEQUENCE
  SEQUENCE 2
```

To create a second sequence that will perform a desired measurement function, decrement the loop counter, and call itself until the loop counter value is equal to zero, press:

SEQ, *NEW SEQ/MODIFY SEQ, SEQUENCE 2 SEQ2*
MEAS, *Trans: E/E S21 FWD*
SCALE REF, *AUTO SCALE*
MARKER FCTN, *MKR SEARCH, SEARCH: MAX*
SEQ, *SPECIAL FUNCTIONS, DECISION MAKING, DECR LOOP COUNTER, IF LOOP COUNTER <> 0, SEQUENCE 2 SEQ2*
SEQ, *DONE SEQ MODIFY*

Creating Sequences

Creating and Editing Sequences

This will create a displayed list as shown:

```
SEQUENCE LOOP 2  
Start of Sequence  
Trans: E/E S21 FWD  
SCALE/DIV  
AUTO SCALE  
MARKER FCTN  
SEARCH MAX  
DECR LOOP COUNTER  
IF LOOP COUNTER < > 0 THEN DO  
SEQUENCE 2
```

To run the loop sequence, press:

PRESET, *SEQUENCE 1 SEQ1*

To build a branch

This measurement example shows you how to create a sequence that will branch the sequence according to the outcome of a limit test. For this example, you must have already saved the following in register 1:

- device measurement parameters
 - a series of active (visible) limit lines
 - an active limit test
- 1** To create a sequence that will recall the desired instrument state, perform a limit test, and branch to another sequence position based on the outcome of that limit test, press:

```
SEQ, NEW SEQ MODIFY, SEQUENCE 1 SEQ1  
SAVE/RECALL, RECALLKEYS MENU, RECALL REG1  
SEQ, SPECIAL FUNCTIONS, DECISION MAKING, IF LIMIT TEST PASS, SEQUENCE 2 SEQ2,  
IF LIMIT TEST FAIL, SEQUENCE 3 SEQ3  
SEQ, DONE SEQ MODIFY
```

This will create a displayed list for sequence 1, as shown:

```
Start of Sequence  
RECALL REG 1  
IF LIMIT TEST PASS THEN DO  
SEQUENCE 2  
IF LIMIT TEST FAIL THEN DO  
SEQUENCE 3
```

- 2** To create a sequence that stores the measurement data for a device that has passed the limit test, press:

```
SEQ, NEW SEQ MODIFY, SEQUENCE 2 SEQ2  
SAVE/RECALL, SELECT DISK, INTERNAL DISK, RETURN, DEFINE DISK-SAVE,  
DATA ARRAY ON, RETURN, SAVE STATE  
SEQ, DONE SEQ MODIFY
```

This will create a displayed list for sequence 2, as shown:

```
Start of Sequence  
INTERNAL DISK  
DATA ARRAY  
ON  
FILENAME  
FILE 0  
SAVE FILE 0
```

Creating and Editing Sequences

- 3** To create a sequence that prompts you to tune a device that has failed the limit test, and calls sequence 1 to retest the device, press the following keys. When entering *TUNE DEVICE*, follow each letter selection with the *SELECT LETTER* key.

```
SEQ, NEW SEQ/MODIFY SEQ, SEQUENCE 3 SEQ3  
DISPLAY, MORE, TITLE, T U N E D E V I C E, DONE  
SEQ, SPECIAL FUNCTIONS, PAUSE, RETURN, DO SEQUENCE. SEQUENCE 1 SEQ1  
SEQ, DONE SEQ MODIFY
```

This will create a displayed list for sequence 3, as shown:

```
Start of Sequence  
TITLE  
TUNE DEVICE  
SEQUENCE  
PAUSE  
DO SEQUENCE  
SEQUENCE 1
```

Running Sequences

To run a sequence

- Press PRESET and the softkey labeled with the desired sequence number
- or*
- SEQ, *DO SEQUENCE* and the softkey labeled with the desired sequence number.

To stop a sequence

- Press LOCAL.

Saving and Printing

To clear a sequence from memory

- 1 Press *SEQ*, *MORE*, *CLEAR SEQUENCE*.
 - 2 Press the softkey of the particular sequence.
-

To change a sequence title

If you are storing sequences on a disk, you should replace the default titles (*SEQ1*, *SEQ2*...).

- 1 To select a sequence that you want to retitle, press:
SEQ, *MORE*, *TITLE SEQUENCE* and select the particular sequence softkey.
The analyzer shows the available title characters. The current title is displayed in the upper-left corner of the screen.
 - 2 You can create a new filename in two ways:
 - If you have an attached DIN keyboard, you can press *f6* and then type the new filename.
 - If you do not have an attached DIN keyboard, press *ERASE TITLE* and turn the front panel knob to point to the characters of the new filename, pressing *SELECT LETTER* as you stop at each character.
The analyzer cannot accept a title that is longer than eight characters. Your titles must also begin with a letter, and contain only letters and numbers.
 - 3 To complete the titling, press *DONE*.
-

To store a sequence on disk

- 1 To format a disk, refer to "Formatting Disks" on page 9-11.
- 2 To save a sequence to the internal disk, press:
SEQ, MORE, STORE SEQ TO DISK and select the particular sequence softkey.
The disk drive access light should turn on briefly. When it goes out, the sequence has been saved.

CAUTION

The analyzer will overwrite a file on the disk that has the same title.

To load a sequence from disk

For this procedure to work, the desired file must exist on the disk in the analyzer drive.

- 1 To view the first six sequences on the disk, press:
SEQ, MORE, LOAD SEQ FROM DISK, READ SEQ FILE TITLS
 - If the desired sequence is not among the first six files, press: *READ SEQ FILE TITLS* until the desired file name appears.
- 2 Press the softkey next to the title of the desired sequence. The disk access light should illuminate briefly.

If you know the title of the desired sequence, you can title the sequence (sequence 1-6) with the name, and load the sequence. This is also how you can control the sequence number of an imported titled sequence.

To erase a sequence from disk

- 1 To view the contents of the disk (six titles at a time), press:
SEQ, MORE, STORE SEQ TO DISK, PURGE SEQUENCES
 - If the desired sequence is not among the first six files, press: *READ SEQ FILE TITLS* until the desired file name appears.
- 2 Press the softkey next to the title of the desired sequence. The disk access light should illuminate briefly.

To print a sequence

- 1** Configure a compatible printer to the analyzer (refer to “Connecting Printers, Plotters, and Disk Drives” on page 12-17).
- 2** To print a sequence, press:
SEQ, *MORE*, *PRINT SEQUENCE* and the softkey for the desired sequence.

Printing and Plotting

Printing and Plotting

In this chapter, you'll learn how to document and record the measurements that you make. This includes importing pictures of the HP 8702D's display into reports that you write on a word processor. Your word processor must be able to import pictures that are in the HP-GL format.

You can also make hardcopies directly on a printer or plotter. This includes HP-GL compatible printers and plotters with HP-IB, parallel, or serial interfaces. In order to make your hardcopies more descriptive, you can even place the current date on them and write descriptive titles.

In addition to creating pictures of the display, you can print, plot, or save to a list of measurement data values and instrument settings.

What you'll find in this chapter

- Saving the Display to a File 12-4
- Printing or Plotting the Display 12-5
- Displaying Lists 12-7
- Selecting Options 12-8
- Connecting Printers, Plotters, and Disk Drives 12-17
- If You Encounter Problems with Printing or Plotting 12-23

Saving the Display to a File

A picture of the display can be saved to a graphics file. The file is written on a disk that you insert into the instrument's front-panel disk drive. This file is in the HP-GL graphics format. Many word processors can import files in this format directly into documents. If your word processor or graphics program can not import this file, you can purchase popular software products that will change the file's format.

Saving the file involves selecting options for plotting a file and then sending the plot to a file rather than to a plotter. (Plot files are in the HP-GL format.) You *cannot* save printer output to a file.

To save a picture in a graphics file

- 1** Press LOCAL, *SET ADDRESSES*, *PLOTTER PORT*, *DISK*.
- 2** Press SAVE/RECALL, *SELECT DISK*, *INTERNAL DISK*.
- 3** Press COPY, *SEL QUAD*, and then *FULL PAGE*.
- 4** Press COPY, *PLOT*.

The HP 8702D automatically assigns the first available default filename for the displayed directory. For example, the name PLOT00.FP (for a DOS-format) or PLOT00FP (for LIF-format) if there were no previous plot files saved to the disk. The two digit sequence number is incremented by one each time a file with a default name is added to the directory.

- 5** In your PC, rename the file so that it has the file extension .hgl.

Printing or Plotting the Display

In this section, you will learn how to create a print or plot of whatever is displayed on the instrument's screen. This includes measurement traces and instrument settings. You can also place multiple pictures on the same page.

To print the display

- 1 Press *COPY*.
- 2 Press *PRINT* if you have connected and configured a printer.
- 3 If you defined the *AUTOFEED OFF*, press *PRINTER FORM FEED* after the message, *COPY OUTPUT COMPLETED*, appears.

To plot the display

- 1 Press *COPY*.
- 2 Press *PLOT* if you have connected and configured a plotter.
- 3 Press *PLOTTER FORM FEED* to print the data the printer has received.

To plot multiple pictures per page

- 1 Press *COPY*, *SEL QUAD*.
- 2 Choose the quadrant where you want your displayed measurement to appear on the hardcopy. The selected quadrant appears in the brackets under *SEL QUAD*.
- 3 Press *PLOT*.
- 4 Make the next measurement that you want to see on your hardcopy.

Printing or Plotting the Display

- 5** Press **COPY**, **SEL QUAD** and choose another quadrant where you want to place the displayed measurement.
- 6** Repeat the previous three steps until you have captured the results of up to four measurements.

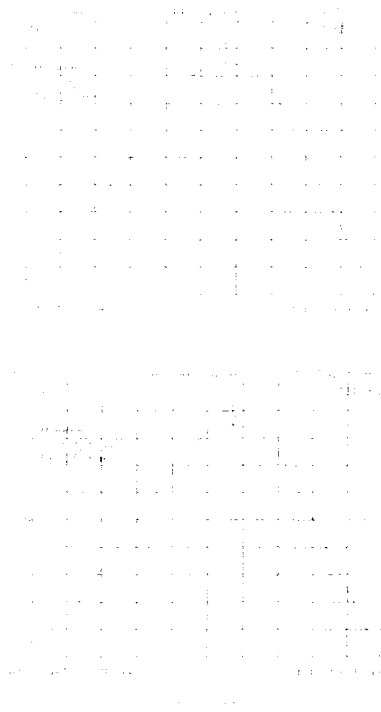

Figure 12-1. Multiple Displayed Measurements

To abort a print or plot

- 1** Press the **LOCAL** key.
- 2** If your peripheral is not responding, press **LOCAL** again.

Displaying Lists

Besides creating hardcopies of the instrument's display, you can also print or plot a tabular listing of each measurement data point or of instrument settings.

If you are printing the list of measurement data points, each page contains 30 lines of data. The number of pages is determined by the number of measurement points that you have selected under the MENU key. The listing also includes limit test information, if you have the limits function activated.

If you choose a tabular listing of the instrument's settings, the tabular listing includes the following parameters for both measurement channels:

- Operating parameters
- Marker parameters
- System parameters that relate to the control of peripheral devices

To display a list of values

- 1** Press *COPY* and then *LIST*.
- 2** Press *LIST VALUES* or *OP PARMS* (*MKRS* and so forth) to select the type of data.
- 3** Press *NEXT PAGE* to display the next page of listed values. Or, you can press *NEXT PAGE* repeatedly to display a particular page of listed values that you want to appear on your hardcopy.
- 4** Choose *PRINT ALL* to print all pages of the listed values.

If you are printing the list of operating parameters, only the first four pages are printed. The fifth page, system parameters, is printed by displaying that page and then pressing *PRINT*.

- 5** Press *PRINT* for a printer, or *PLOT* for a plotter, to create a hardcopy of a single displayed page of listed values.

Selecting Options

The options described in this section allow you to modify the pictures plotted, printed, or saved in graphics files. For example, you can write a title on the display and show the current date and time. You can also switch between monochrome and color output.

Because graphics files of the display are saved in the HP-GL format, changing plotter options affects these files.

The options that you set are reset to their default values whenever the instrument's power is cycled. So, if you want to save the option settings, save the instrument's state as described in Chapter 9, "Saving Data, States, and the Display".

Table 12-1. Default Values for Printing Parameters

Printing Parameter	Default Setting
Auto Feed	on
Printer Colors	
Channel 1 Data	magenta
Channel 1 Memory	green
Channel 2 Data	blue
Channel 2 Memory	red
Graticule	cyan
Warning	black
Text	black

Table 12-2. Plotting Parameter Default Values

Plotting Parameter	Default
Select Quadrant	Full page
Auto Feed	ON
Define Plot	All plot elements on
Plot Scale	Full
Plot Speed	Fast
Line Type	7 (solid line)
Pen Numbers: Channel 1	
Data	2
Memory	5
Graticule	1
Text	7
Marker	7
Pen Numbers: Channel 2	
Data	3
Memory	6
Graticule	1
Text	7
Marker	7

To write a title

- 1 Press *DISPLAY, MORE, TITLE*.
 - 2 Press *ERASE TITLE*.
 - 3 Turn the front-panel knob to move the arrow pointer to the first character of the title.

The *NEWLINE* and *FORMFEED* keys are not intended for creating display titles. Those keys are for creating commands to send to peripherals, during a macro program.
 - 4 Press *SELECT LETTER*.
 - 5 Repeat the previous two steps to enter the rest of the characters in your title.

You can enter a title that has a maximum of 50 characters. Press *BACKSPACE* if you enter an incorrect character.
 - 6 Press *DONE* to complete the title entry.
-

To display the date and time

- 1 Press *SYSTEM, SET CLOCK*.
 - 2 Press *SET YEAR* and enter the current year, followed by *x1*.
 - 3 Press *SET MONTH* and enter the current month of the year, followed *x1*.
 - 4 Press *SET DAY* and enter the current day of the month, followed by *x1*.
 - 5 Press *SET HOUR* and enter the current hour of the day (0-23), followed by *x1*.
 - 6 Press *SET MINUTES* and enter the next immediate minute, followed by *x1*.
 - 7 Press *ROUND SECONDS* when the current time is exactly as you have set it.
 - 8 Press *TIME STAMP* until *TIME STAMP ON* appears on the softkey label.
-

To select color prints

- 1** Press *COPY*, *DEFINE PRINT*.
- 2** Select one of the following options:
 - Press *PRINT: MONOCHROME* if you are using a black and white printer, or you want just black and white from a color printer.
 - Press *PRINT: COLOR* if you are using a color printer.

To control the paper feed

- 1** Press *COPY* and then *DEFINE PRINT* or *DEFINE PLOT*.
- 2** Press *AUTO-FEED* until the correct choice is highlighted:
 - Choose *AUTO-FEED ON* if you want one picture per page.
 - Choose *AUTO-FEED OFF* if you want several pictures per page.

Laser printers and some DeskJet printers do not begin to print until a full page, or a partial page and a form feed, have been received. Plotters ignore the *AUTO-FEED ON* selection when you are plotting to a quadrant.

To select the information plotted

- 1 Press *COPY*, *DEFINE PLOT*.
- 2 Choose which of the following measurement display elements that you want to appear on your picture:
 - *PLOT DATA ON* to include the measurement data trace.
 - *PLOT MEM ON* to include the displayed memory trace.
 - *PLOT GRAT ON* to include the graticule and the reference line.
 - *PLOT TEXT ON* to include all of the displayed text. (Not including marker values or softkey labels.)
 - *PLOT MKR ON* to include markers and marker values.

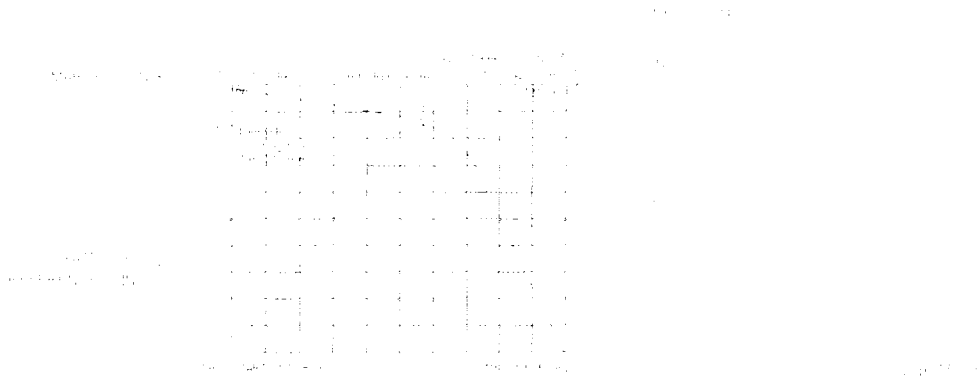

Figure 12-2. Plot Components Available through Definition

To select plotter colors

- 1 Press *COPY*, *DEFINE PLOT*.
- 2 Press *MORE* and select the plot element where you want to change the pen number. For example, *PEN NUM DATA*, and then modify the pen number.
 Press *x1* after each modification.

You can set all the pen numbers to black for a plot in black and white. You must define the pen numbers for each measurement channel (channel 1 and channel 2).

Table 12-3. Default Pen Numbers for Plot Elements

Corresponding Key	Plot Element	Channel 1 Pen Numbers	Channel 2 Pen Numbers
<i>PEN NUM DATA</i>	Measurement Data Trace	2	3
<i>PEN NUM MEMORY</i>	Displayed Memory Trace	5	6
<i>PEN NUM GRATICULE</i>	Graticule and Reference Line	1	1
<i>PEN NUM TEXT</i>	Displayed Text	7	7
<i>PEN NUM MARKER</i>	Displayed Markers and Values	7	7

Table 12-4. Pen Numbers and Default Colors

Pen Number	Default Color
0	white
1	cyan
2	magenta
3	blue
4	yellow
5	green
6	red
7	black

To select plotter line styles

- 1 Press *COPY*, *DEFINE PLOT*, *MORE*, and then *MORE*.
- 2 Press *LINE TYPE DATA* to modify the line type for the data trace. Then enter the new line type, followed by *x1*.
- 3 Press *LINE TYPE MEMORY* to modify the line type for the memory trace. Then enter the new line type, followed by *x1*.

Table 12-5. Default Line Types for Plot Elements

Plot Elements	Channel 1 Line Type Numbers	Channel 2 Line Type Numbers
Data Trace	7	7
Memory Trace	7	7

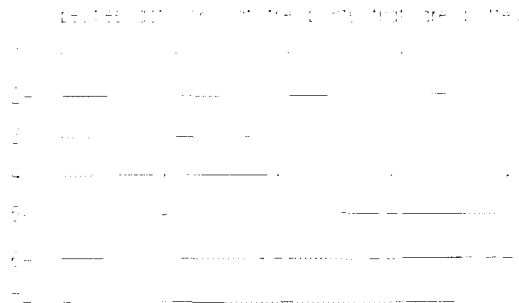

Figure 12-3. Line Types Available

To set drawing size on plotters

- 1 Press *COPY*, *DEFINE PLOT*, *MORE*, *MORE*.
- 2 Press *SCALE PLOT* until the selection appears that you want.
 - Choose *SCALE PLOT [FULL]* if you want the normal scale selection for plotting. This includes space for all display annotations, such as marker values and stimulus values. The entire analyzer display fits within the defined boundaries of P1 and P2 on the plotter, while maintaining the exact same aspect ratio as the display.
 - Choose *SCALE PLOT [GRAT]* if you want the outer limits of the graticule to correspond to the defined P1 and P2 scaling point on the plotter. (Intended for plotting on preprinted rectangular or polar forms.

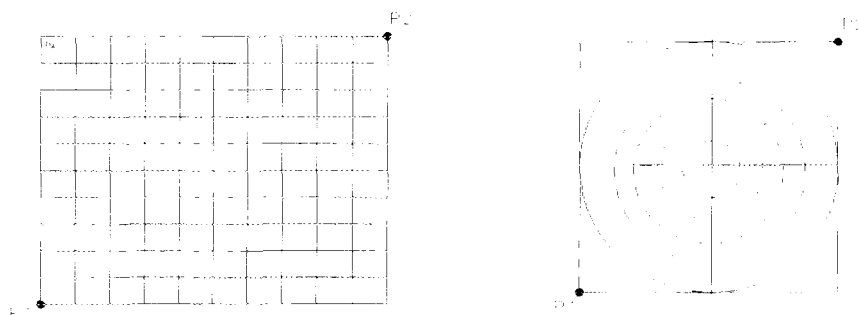

fig. 12-4

Figure 12-4. Locations of P1 and P2 in *SCALE PLOT [GRAT]* Mode

To set plotter speed for transparencies

- 1** Press *COPY, DEFINE PLOT, MORE, MORE*.
- 2** Press *PLOT SPEED* until the plot speed appears that you want.
 - Choose *PLOT SPEED [FAST]* for normal plotting.
 - Choose *PLOT SPEED [SLOW]* for plotting directly on transparencies; the slower speed provides a more consistent line width.

To reset the options

- Press *COPY, DEFINE PRINT, DEFAULT PRNT SETUP*.
- Press *COPY, DEFINE PLOT, MORE, MORE, DEFAULT PLOT SETUP*.

Connecting Printers, Plotters, and Disk Drives

This section provides step-by-step instructions for connecting and configuring printers, plotters, and external HP-IB disk drives. The selections chosen in this section are stored in non-volatile memory. Therefore, they are not affected if you press PRESET or switch off the instrument's power.

If you have one of the printers listed below, you have the option of configuring this printer as a plotter. This is because these plotters support the HP-GL/2 language. (You can, of course, still configure them as a printer.) Configuring these printers as plotters gives you the opportunity to select plotter options as described in "Selecting Options" on page 12-8. If you want to configure your printer as a plotter, refer to "To connect a plotter" on page 12-21.

- *ThinkJet* (QuietJet)
- *DeskJet* (only DeskJet 1200C)
- *LaserJet* (only LaserJet III and IV)
- *PaintJet*
- *Epson-P2* (printers that conform to the ESC/P2 printer control)

Table 12-6. Recommended Printer and Plotter Cables

Interface	Cables
Parallel	HP 92284A
HP-IB	HP 10833A, 10833B, 10833D
Serial	HP 24542G

Table 12-7. Default Addresses for HP-IB Peripherals

Peripheral	Default HP-IB Address
Printer	01
Plotter	05
Power Meter	13
Disk Drive	00
Computer Controller	21

To connect a printer

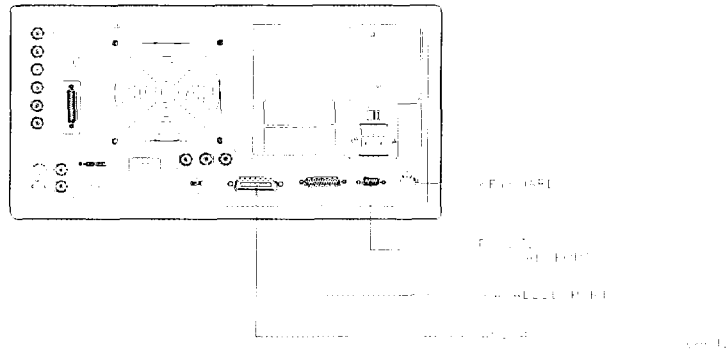

- 1** Connect the printer to the interface port.
- 2** Press *LOCAL*, *SET ADDRESSES*, *PRINTER PORT*.
- 3** Press the key that corresponds to the printer interface: *HPIB*, *PARALLEL* (parallel port), or *SERIAL* (serial port).
- 4** If you selected *HPIB*, the HP-IB address is active so you can then set the address of your printer. The default HP-IB printer address is 1.
- 5** If you select *SERIAL*, adjust the HP 8702D's baud rate and handshaking protocol:
 - a** Press *PRINTER BAUD RATE*, and use the up and down arrow front-panel keys to select the baud rate.
 - b** Set the transmission control, *XMIT CNTRL* (handshaking protocol) to either *XON/XOFF* or *DTR/DSR* (equal to the transmission control set on the peripheral).

XON/XOFF selects software handshaking. *DTR/DSR* selects hardware handshaking. Consult the printer's manual for the proper settings.

6 Press *PRNTR TYPE* until the correct printer choice appears:

- *ThinkJet* (QuietJet)
- *DeskJet* (except for HP DeskJet 540)
- *LaserJet*
- *PaintJet*
- *Epson-P2* (printers that conform to the ESC.P2 printer control language)
- *DJ540* (converts 100 dpi raster information to 300 dpi raster format)

To connect a plotter

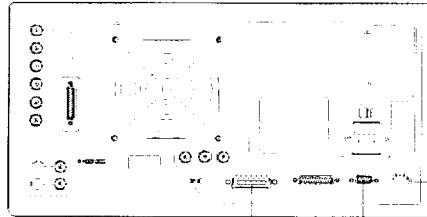

- 1** Connect the plotter to the interface port.
- 2** Press *LOCAL*, *SET ADDRESSES*, *PLOTTER PORT*.
- 3** Press the key that corresponds to the plotter interface: *HP-IB*, *PARALLEL* (parallel port), or *SERIAL* (serial port).
- 4** If you selected *HP-IB*, the HP-IB address is active so you can then set the address of your plotter. The default HP-IB plotter address is 5.
- 5** If you select *SERIAL*, adjust the HP 8702D's baud rate and handshaking protocol:
 - a** Press *PLOTTER BAUD RATE*, and use the up and down arrow front-panel keys to select the baud rate.
 - b** Set the transmission control, *XMIT CNTRL* (handshaking protocol) to either *XON/XOFF* or *DTR/DSR* (equal to the transmission control set on the peripheral).

XON/XOFF selects software handshaking. *DTR/DSR* selects hardware handshaking. Consult the printer's manual for the proper settings.
- 6** Press *PLTR TYPE* until the correct plotter selection appears:
 - Choose *PLTR TYPE [PLOTTER]* if you will be using a plotter to make your hardcopy.
 - Choose *PLTR TYPE [HPGL PRT]* if you will be using an HPGL compatible printer to make your hardcopy.

To connect an external HP-IB disk drive

- 1** Press LOCAL, *SET ADDRESSES*, *PLOTTER PORT*, *DISK*.
- 2** Press SAVE/RECALL, *SELECT DISK*, and then *EXTERNAL DISK*.
- 3** Press *CONFIGURE EXT DISK*, *ADDRESS: DISK* and enter the HP-IB address to the disk drive (default is 00) followed by x1.
- 4** Press LOCAL, *DISK UNIT NUMBER* and enter the drive where your disk is located, followed by x1.
- 5** If your storage disk is partitioned, press *VOLUME NUMBER* and enter the volume number where you want to store the instrument state file.

If You Encounter Problems with Printing or Plotting

If you encounter a problem when you are printing or plotting, check the following list for possible causes:

- Look in the instrument's display message area. The instrument may show a message that will identify the problem. Refer to the "Error Messages" chapter in the *HP 8702D Reference* manual if a message appears.
- If necessary, refer to the configuration procedures in this chapter to check that you have done the following:
 - connected an interface cable between the peripheral and the analyzer
 - connected the peripheral to ac power
 - switched on the power
 - switched the peripheral on line
 - selected the correct printer or plotter type
- If you are using a laser printer for plotting, and the printer is outputting partial plots, the printer may require more memory or page protection activated.
- Make sure that the analyzer address setting for the peripheral corresponds to the actual HP-IB address of the peripheral. The procedure is explained earlier in this chapter.
- Make sure that the analyzer is in system controller mode, by pressing *LOCAL*, *SYSTEM CONTROLLER*, if the analyzer is not connected to an external controller. Otherwise, the analyzer must be in the pass control mode.
- Substitute the interface cable.
- Substitute a different printer or plotter.

Printing and Plotting

If You Encounter Problems with Printing or Plotting

Performing Calibrations

Managing Calibration Kits

Error-correction procedures increase measurement accuracy by removing repeatable measurement variations from the test setup. Sources, receivers, interconnecting cables, and adapters all introduce variations in magnitude and phase that can mask the actual response of the device being tested. During an error-correction procedure, known standard devices are measured and the results compared to standard mathematical models stored in the HP 8702D's memory. These mathematical models are known as calibration kits.

Error-corrections are valid for current instrument settings

An error-correction procedure is valid only for a specific instrument state, which must be set before the procedure is started. If you change any of the following settings, you will invalidate the correction, and the instrument will switch the correction off unless you use the interpolated error correction feature.

- Frequency range
- Number of measurement points
- Sweep type

The error correction quality may be degraded (the `Cor` annotation changes to `C?`) if you change one of the following settings:

- Sweep time
- Bandwidth
- Output power

If you activate averaging, the instrument may increase the sweep time if more time is needed to calculate the averages. If the sweep time changes, you will see the `Cor` annotation change to `C?`. The number of averages does not affect a sweep cycle time. Therefore, if you use averaging for error correction, leave it on for the measurement, and set the averaging factor to 1 for a faster sweep.

What you'll find in this chapter

- Entering Calibration Kits and Standards 13-4
 - Entering an HP 83400-series source's calibration standard 13-5
 - Selecting a standard cal kit 13-6
 - Entering an HP 83400-series receiver calibration kit 13-6
- Modifying User-Defined Electrical Kits 13-7
 - Modifying a standard 13-9
 - Modifying a TRL* standard 13-11
- Performing Error-Correction 13-13
 - Types of error-correction 13-18
 - Calibration standards 13-20
- Procedures for Error-Correcting Measurements 13-21
 - Frequency response reflection calibration for E/E measurement 13-22
 - Frequency response transmission calibration for E/E measurement 13-25
 - One-port reflection calibration for E/E measurement 13-27
 - Full two-port calibration for E/E measurement 13-30
 - TRM* (TRL*) calibration for E/E measurement 13-33
 - Interpolated error calibration for E/E measurement 13-34
 - Source response calibration for E/O measurement 13-37
 - Source thru/receiver response calibration for E/O measurement 13-39
 - Source response and match calibration for E/O measurement 13-41
 - Receiver response calibration for O/E measurement 13-43
 - Receiver response and match calibration for O/E measurement 13-45
 - Calibration for Reflection O/O measurements 13-49
 - Calibration for Transmission O/O measurements 13-51
- Modifying Optical Standards 13-53
 - To define a reflector standard 13-53
 - To define a thru standard 13-53
- Calibrating with a Power Meter 13-55
 - Entering power sensor calibration data 13-57
 - Editing frequency segments 13-58
 - Deleting frequency segments 13-59
 - Compensating for directional coupler response 13-60
 - Using sample-and-sweep correction mode 13-61
 - Using continuous correction mode 13-63
 - Calibrating the HP 8702D to measure absolute power 13-65

Entering Calibration Kits and Standards

HP 83400-series lightwave sources and receivers have calibration data which must be entered into the HP 8702D. The data is supplied on a disk and printed on a label. The most accurate data is contained on the disk. The calibration data for newer lightwave sources and receivers is supplied on both a DOS-formatted disk and a LIF-formatted disk. The DOS disk can be read using the front-panel disk drive of the HP 8702D. The HP 8702B uses the LIF-formatted disk.

Calibration standard definitions come in the following forms:

- Already loaded in the HP 8702D's memory.

For optical transmission measurements, a thru connection (short length of fiber-optic cable) is used. For reflection measurements, a Fresnel reflection (3.5% reflected power) is used. This is a clean connector on the output of a lightwave coupler. For electrical measurements, standard devices include short circuit, open circuit, termination (for example, 50Ω load), and thru connection.

- Provided with the device and must be loaded into the HP 8702D's memory.

For example, the HP 83400-series lightwave sources and receivers are shipped with calibration standard data stored on a disk. This disk must be placed into the instrument's front-panel disk drive so that the data can be loaded into memory.

- Entering the parameters to define your own calibration standards.

Entering an HP 83400-series source's calibration standard

Entering the calibration data from disk

If the calibration data for the source is supplied on a DOS-formatted disk, perform the following steps:

- 1** Insert the disk into the front-panel disk drive of the HP 8702D.
- 2** Press *CAL*, *CAL KITS & STDS*, *SOURCE STANDARDS*, *LOAD SRC DISK MENU*. This will display the disk directory screen.
- 3** Use the arrow keys or front panel knob to select a cal data file.
- 4** Load the cal data file into either of two internal registers by pressing the *LOAD SRCx DISK* softkey.
- 5** To display the calibration data, press *SRCx→MEMORY* and then use the Display menu to turn on the trace memory.

Entering the calibration coefficients manually

- 1** To define the source standard without using a disk, but with much lower accuracy, enter coefficients printed on the label.
 - a** Press *CAL*, *CAL KITS & STDS*, *SOURCE STANDARDS*, *ENTER SRC COEFF MENU*.
 - b** Press each softkey corresponding to the nine coefficients (A through I), using the *MORE* softkey, and enter the coefficients. The coefficients are listed on a label that is on the source.
 - c** After all of the coefficients are entered, press *RETURN*.
 - d** Press *LABEL STD*.
 - e** Use the front-panel knob to highlight a letter and then press the *SELECT LETTER* softkey to write a title for the calibration data. When the title is entered, press *DONE*.
 - f** Press *STD DONE (DEFINED)* and then *SAVE SRC COEFF*.

Selecting a standard cal kit

Specifying calibration kits

In addition to the menus for the different calibration procedures, the CAL key provides access to a series of menus used to specify the characteristics of calibration standards. Several default calibration kits with different connector types have predefined standards and are valid for most applications. The numerical definitions for most Hewlett-Packard calibration kits can be referenced in the calibration kit operating and service manuals, or can be viewed on the analyzer. The standard definitions can also be modified to any set of standards used.

To select a standard cal kit, press CAL, *CAL KITS & STDS*, *SELECT CAL KIT*. Press the key corresponding to the standard HP calibration kit.

Entering an HP 83400-series receiver calibration kit

Entering the calibration data from disk

If the calibration data for the receiver is supplied on a DOS-formatted disk, or LIF-formatted disk, perform the following steps:

- 1** Insert the disk into the front-panel disk drive of the HP 8702D.
- 2** Press CAL, *CAL KITS & STDS*, *RECEIVER STANDARDS*, *LOAD RCVR DISK MENU*, *LOAD RCVRx DISK*.
- 3** Use the arrow keys or front panel knob to select a cal data file.
- 4** Load the cal data file into either of two internal registers by pressing the *LOAD SRCx DISK* softkey.

Refer to "Entering the calibration coefficients manually" on page 13-5 for more information.

Modifying User-Defined Electrical Kits

Hewlett-Packard strongly recommends that you read *Application Note 8510-5A*, HP part number 5956-4352, before attempting to view or modify standard definitions. Although the application note is written for the HP 8510 family of network analyzers, it also applies to the HP 8702D.

This portion of the correction chapter provides a summary of the information in the application note, as well as HP 8702D menu-specific information. Refer to chapter 5 of the *HP 8702D Reference* manual for more information.

Numerical data for most Hewlett-Packard calibration kits is provided in the calibration kit manuals.

Important definitions you'll need to know

- A "standard" (represented by a number 1-8) is a specific, well-defined, physical device used to determine systematic errors.
- A standard "type" is one of five basic types that define the form or structure of the model to be used with that standard (short, open, load, delay/thru, and arbitrary impedance).
- Standard "coefficients" are numerical characteristics of the standards used in the model selected.
- A standard "class" is a grouping of one or more standards that determines which standards are used in a particular correction procedure.

The process uses four simple steps

The following steps are used to modify or define user kit standard models, contained in the analyzer memory:

- 1** To modify a cal kit, first select the predefined kit to be modified. This is not necessary for defining a new cal kit.
- 2** Define the standards. For each standard, define which "type" of standard it is and its electrical characteristics.
- 3** Specify the class where the standard is to be assigned.

Modifying User-Defined Electrical Kits

- 4 Store the modified cal kit.

The TRL*/LRM* technique requires a user-defined kit

In order to use the TRL*/LRM* technique, the calibration standard's characteristics must be entered into the instrument's user-defined calibration kit.

The procedure in this section shows you how to define a calibration kit to utilize a set of TRM (thru, reflect, match) standards. The example TRM kit contains the following:

- zero length LINE (THRU)
- flush short for the REFLECT standard (0 second offset)
- 50 ohm termination for the MATCH (infinite length line)

Modifying a standard

- 1 Press *CAL, CAL KITS & STDS, SELECT CAL KIT*.
- 2 Select the softkey that corresponds to the kit you want to modify.
- 3 Press *RETURN, MODIFY, DEFINE STANDARD*.
- 4 Select the standard that you want to modify. Refer to your calibration kit manual for the numbers of the specific standards in your kit. For example, to select a short, press: 1.

Table 13-1. Typical Calibration Kit Standard and Corresponding Number

Typical Standard Type	Default Number
short	1
open	2
load	3
delay/thru	4

- 5 Press the underlined softkey. For example, if you selected 1 in the previous step, *SHORT* should be the underlined softkey.
- 6 This step applies only to the *open*. Go to the next step if you selected any other standard.
 - a Press *OPEN, C0*. Observe the value on the analyzer screen.
 - b Use the entry keys, or knob on the analyzer front panel to change the value. Press *x1* to enter the value.
 - c Repeat the modification for *C1, C2, and C3*.
- 7 This step applies only to the *load*. Go to the next step if you selected any other standard.
 - a Ensure that the correct load type is underlined: *FIXED* or *SLIDING*.
- 8 Press *SPECIFY OFFSET, OFFSET DELAY* and observe the value on the analyzer screen. To change the value, use the entry keys, or knob, on the front panel. Press *x1* to enter the value.

Modifying User-Defined Electrical Kits

- 9 Repeat the value modification for the characteristics listed below:
 - *OFFSET LOSS*
 - *OFFSET Z0*
 - *MINIMUM FREQUENCY*
 - *MAXIMUM FREQUENCY*
- 10 Ensure that the correct transmission line is underlined: *COAX* or *WAVEGUIDE*.
- 11 Press *STD OFFSET DONE, STD DONE (DEFINED)*.
- 12 Press *DEFINE STANDARD* and repeat Step 4 through Step 11 for the remaining standards.
- 13 If you made modifications to any of the standard definitions, follow the remaining steps in this procedure to assign a kit label, and store them in the non-volatile memory. The new set of standard definitions will be available under *USER KIT*, until you save another user kit.
- 14 Press *LABEL KIT, ERASE TITLE*. Use the front panel knob to move the pointer to a character and press *SELECT LETTER*.
- 15 Press *DONE, KIT DONE (MODIFIED), SAVE USER KIT*.

Note that the name of the newly modified user kit is now listed under the *MODIFY [Kit/title]* softkey. You may also save the user kit to disk, by selecting the particular kit at the time you save a measurement result

Modifying a TRL* standard

- 1 Press the following keys to start modifying the standard definitions:

PRESET, CAL, CAL KITS & STDS, MODIFY CAL KIT, DEFINE STANDARD

Calibration standard #1 is selected as shown on the analyzer display, and the *SHORT* standard type is underlined in the softkey menu. (In this example, the REFLECT standard is a SHORT.)

- 2 Press the following keys:

*SHORT, SPECIFY OFFSET, OFFSET DELAY
0, x1, STD OFFSET DONE, STD DONE (DEFINED)*

- 3 To define the THRU/LINE standard, press:

*DEFINE STANDARD, 4, x1
DELAY/THRU, SPECIFY OFFSET, OFFSET DELAY, 0, x1
STD OFFSET DONE, STD DONE (DEFINED)*

- 4 To define the LINE/MATCH standard, press:

*DEFINE STANDARD, 3, x1
LOAD*

- 5 For the purposes of this example, change the name of the standard by pressing *LABEL STD* and modifying the name to "MATCH."

- 6 When the title area shows the new label, press:

DONE, STD DONE (DEFINED)

- 7 To assign the calibration standards to the various TRL*/LRM* calibration classes, press:

SPECIFY CLASS, S11A, MORE, FWD MTCH

This specifies the standards for both the "S11A" class and the "REFLECT Forward Match" class.

- 8 Since you previously designated standard #1 for the REFLECT standard, press:

1, x1, SPECIFY CLASS DONE

- 9 To designate the standard for the "REFLECT Reverse Match," press:

SPECIFY CLASS, S22A MORE REV MTCH, 1, x1

You have now defined the same calibration standard (the "flush" short) for the REFLECT classes.

Modifying User-Defined Electrical Kits

- 10 Since you previously designated standard #3 for the LINE/MATCH standard, press:
 - S11B LN FW MTCH*, 3, x1 ("LINE Forward Match")
 - S11C LN FW TRAN*, 3, x1 ("LINE Forward Transmission")
 - S22B LN RV MTCH*, 3, x1 ("LINE Reverse Match")
 - S22C LN RV TRAN*, 3, x1 ("LINE Reverse Transmission")
- 11 Since you previously designated standard #4 for the THRU/LINE standard, press:
 - MORE FWD TRANS*, 4, x1 ("THRU/LINE Forward Transmission")
 - REV TRANS*, 4, x1 ("THRU/LINE Reverse Transmission")
 - FWD MATCH*, 4, x1 ("THRU/LINE Forward Match")
 - REV MATCH*, 4, x1 ("THRU/LINE Reverse Match")
- 12 To complete the specification of class assignments, press *SPECIFY CLASS DONE*.
- 13 Press *LABEL CLASS* and change the label of the "REFLECT Forward Match" class to "TRM SHORT" for the following standards:
 - *S11A RE FW MTCH*
 - *S22A RE RV MTCH*
- 14 Change the label of the "LINE/MATCH" class to "TRM LOAD" for the following standards:
 - *S11B LN FW MTCH*
 - *S11C LN FW TRAN*
 - *S22B LN RV MTCH*
 - *S22C LN RV TRAN*
- 15 Press *MORE* and change the label of the "THRU/LINE" class to "TRMTHRU" for the following standards:
 - *FWD TRANS*
 - *REV TRANS*
 - *FWD MATCH*
 - *REV MATCH*
- 16 Press *LABEL CLASS DONE*.
- 17 Press *LABEL KIT* and create a label up to 8 characters long. For this example, enter "TRM KIT1", *DONE*.
- 18 To save the newly defined kit into nonvolatile memory, press *KIT DONE (MODIFIED)*, *SAVE USER KIT*.

Performing Error-Correction

The error-correction procedures in this section increase measurement accuracy by removing repeatable measurement variations from the test setup. Sources, receivers, interconnecting cables, and adapters all introduce variations in magnitude and phase that can mask the actual response of the device being tested. During an error-correction procedure, known standard devices are measured and the results compared to standard mathematical models stored in the HP 8702D's memory. These mathematical models are known as calibration kits.

Error-corrections are valid for current instrument settings

An error-correction procedure is valid only for a specific instrument state, which must be set before the procedure is started. If you change any of the following settings, you will invalidate the correction, and the instrument will switch the correction off unless you use the interpolated error correction feature.

- frequency range
- number of measurement points
- sweep type

The error correction quality may be degraded (the `Cor` annotation changes to `C?`) if you change one of the following settings:

- sweep time
- bandwidth
- output power

If you activate averaging, the instrument may increase the sweep time if more time is needed to calculate the averages. If the sweep time changes, you will see the `Cor` annotation change to `C?`. The number of averages does not affect a sweep cycle time. Therefore, if you use averaging for error correction, leave it on for the measurement, and set the averaging factor to 1 for a faster sweep.

Performing Error-Correction

Each measurement channel has its own error corrections

An error-correction procedure can be performed for each measurement channel. If the two channels are stimulus coupled and the input ports are the same for both channels, they share the same correction data.

There are six choices of calibration procedures for electrical-to-electrical devices: frequency response, frequency response and isolation, S_{11} one-port, S_{22} one-port, full two-port, and one-path two-port.

Frequency response correction

The frequency response correction effectively removes the frequency response errors for reflection or transmission measurements. This procedure may be adequate for measurement of well matched low-loss devices. This is the simplest error correction to perform, but also the least accurate.

Optional steps are provided for an isolation correction which additionally removes crosstalk errors in transmission measurements or directivity errors in reflection measurements. This procedure may be adequate for measurements of well matched high-loss at devices. Isolation correction can be omitted for most measurements, except where a measurement range greater than 90 dB is required.

S_{11} and S_{22} one-port correction

The S_{11} and S_{22} one-port correction procedure is designed for high accuracy reflection measurements of one-port devices or properly terminated two-port devices. The only difference between S_{11} and S_{22} correction is the measurement parameter that you select during the procedure. This is the recommended error-correction procedure for all reflection measurements when full two-port correction is not used. This procedure accomplishes the following tasks:

- Removes directivity errors
- Removes source match errors
- Removes frequency response

E/O response and match correction

Provides the best accuracy when measuring E/O devices. It is recommended when the input impedance of the test device does not match the system impedance of the lightwave component analyzer. This procedure removes:

- Source match errors in forward direction
- Isolation errors in forward direction
- Frequency response in forward direction

O/E response and match

Provides the best accuracy for O/E devices. It is recommended when the input impedance of the test device does not match the system impedance of the lightwave component analyzer. This procedure removes:

- Directivity errors in forward direction
- Source match errors in forward direction
- Load match errors in forward direction
- Isolation errors in forward direction
- Frequency response in forward direction

Full two-port correction

The full two-port correction provides the best magnitude and phase measurement accuracy for both transmission and reflection measurements of two-port devices. Since the instrument takes both forward and reverse sweeps, this procedure takes more time than the other correction procedures. This procedure removes the following items:

- Directivity errors in forward and reverse directions
- Source match errors in forward and reverse directions
- Load match errors in forward and reverse directions
- Isolation errors in forward and reverse directions (optional)
- Frequency response in forward and reverse directions

TRM* (TRL*) correction

The HP 8702D has the capability for making calibrations using the TRL (thru-reflect-line) method. This method is convenient in that calibration standards can be fabricated for a specific measurement environment, for example, a transistor test fixture or microstrip. This convenience allows for accurate measurements of, for example, chip packages, MMIC's, RFIC's, or beam-lead devices.

For coaxial, waveguide, and other environments where high-quality impedance standards are readily available, the traditional short, open, load, thru (SOLT) method still provides the most accurate results since all of the significant systematic errors are reduced. This method is implemented in the HP 8702D in the form of S_{11} 1-port, S_{22} 1-port, and full 2-port calibration selections.

In all measurement environments, the user must provide calibration standards for the desired calibration to be performed. The advantage of TRL is that only three standards need to be characterized, as opposed to four in the traditional

Performing Error-Correction

open, short, load, and thru full 2-port calibrations. Further, the requirements for characterizing the T, R, and L standards are less stringent and these standards are more easily fabricated.

The letters TRL, LRL, LRM are often interchanged depending on the standards used. For example, LRL indicates that two lines and a reflect standard are used; TRM indicates that a thru, reflection and match standards are used. All of these refer to the same basic method.

The TRL*/LRM* calibration used in the HP 8702D relies on the characteristic impedance of simple transmission lines, rather than on a set of discrete impedance standards. Since transmission lines are relatively easy to fabricate (in a microstrip, for example), the impedance of these lines can be determined from the physical dimensions and substrate's dielectric constant. For a fixture, TRL* can eliminate the effects of the fixture's loss and length, but does not completely remove the effects due to the mismatch of the fixture.

Because the technique relies on the characteristic impedance of transmission lines, the mathematically equivalent method LRM* (for line-reflect-match) may be substituted for TRL*. Since a well-matched termination is an infinitely long transmission line, it is well suited for low (RF) frequency calibrations. Achieving a long line standard for low frequencies is often physically unrealizable.

Move the measurement reference plane

You can add electrical delay in seconds to the measurement ports to extend the apparent location of the measurement reference plane to the ends of the cables. This is equivalent to adding a length of perfect air line and makes it possible to measure the delay response of the device only, instead of the device plus the cable.

Clarifying type-N connector sex

When you are performing error-correction for a system that has type-N test port connectors, the softkey menus label the sex of the test port connector - *not* the calibration standard connector. For example, the label *SHORT (F)* refers to the short that will be connected to the *female* test port.

When to use interpolated error-correction

You may want to use interpolated error-correction when you choose a subset of a frequency range that you already corrected, or when you change the number of points. This feature also allows you to change the parameters in a 2-port correction, such as IF bandwidth, power, or sweep time. The HP 8702D calculates the systematic errors from the errors of the original correction. The quality of the interpolated error-correction depends on the amount of phase shift and amplitude change of the error coefficients between measurement points. If the phase shift is $<180^\circ$ per five measurement points, the interpolated error-correction can be a great improvement over uncorrected measurement.

Measurement accuracy and system characteristics can be affected when:

- adapting to a different connector type or impedance.
- connecting a cable between the test device and an HP 8702D test port.
- connecting any attenuator or other such device on the input or output of the test device.

If your test setup meets any of the conditions above, the system characteristics which may be affected include:

- amplitude at device input
- frequency response accuracy
- directivity
- crosstalk (isolation)
- source match
- load match

Types of error-correction

Several types of error correction are available that remove from one to twelve systematic errors. The full 2-port correction effectively removes all twelve correctable systematic errors. Some measurements do *not* require correction for all twelve errors. Table 13-2 explains each correction and its use.

Table 13-2. Purpose and Use of Different Error-Correction Procedures

Correction Procedure	Corresponding Measurement	Errors Corrected	Standard Devices
Response	Transmission or reflection measurement when the highest accuracy is not required.	Frequency response.	Thru for transmission, open or short for reflection
Response & isolation	Transmission of high insertion loss devices or reflection of high return loss devices. Not as accurate as 1-port or 2-port correction.	Frequency response plus isolation in transmission or directivity in reflection.	Same as response plus isolation standard (load)
S ₁₁ 1-port	Reflection of any one-port device or well terminated two-port device.	Directivity, source match, frequency response.	Short, open, and load.
S ₂₂ 1-port	Reflection of any one-port device or well terminated two-port device.	Directivity, source match, frequency response.	Short, open, and load.
Full 2-port ^a	Transmission or reflection of highest accuracy for two-port devices.	Directivity, source match, load match, isolation, frequency response, forward and reverse	Short, open, load, and thru (Two loads for isolation)
TRL*/LRM*	Transmission or reflection when highest accuracy is not required.	Directivity, isolation, frequency response (forward and reverse)	Thru, reflect, line, or line, reflect, match, or thru, reflect, match
E/O response and match	Transmission of highest accuracy.	Directivity, source match, load match, isolation, frequency response, (forward).	Short, open, load, and calibrated source.
O/E response and match	Transmission of highest accuracy.	Directivity, isolation, frequency response (forward).	Short, open, load, thru, and calibrated receiver.

a. One-path, 2-port error correction is a variation of full 2-port that requires reversing the test device between forward and reverse measurements. Since the standard instrument does this with its internal switch, full 2-port is recommended because it is more convenient and more accurate. If the instrument should be used in a configuration where the incident/reflected signal separation device is external to it, then one-path 2-port would be useful.

Error-correction is only valid for a specific stimulus state that you must select before you start a correction. If you change any of the following parameters, you will invalidate the correction and the analyzer will switch the correction off, unless you use the interpolated error correction feature.

- frequency range
- number of points
- sweep type

The error-correction quality may be degraded (COR changes to C?), if you change the following stimulus state parameters:

- sweep time
- system bandwidth
- output power

NOTE

If you activate averaging, the analyzer may increase the sweep time if more time is needed to calculate the averages. If the sweep time changes, you will see COR change to C?. The number of averages does not affect a sweep cycle time. Therefore, if you use averaging for error-correction, leave it on for the measurement and set the averaging factor to 1, for a faster sweep.

Calibration standards

The quality of the error-correction is limited by two factors: (1) the difference between the model of the calibration standards and the actual electrical characteristics of those standards, and (2) the condition of the calibration standards. To make the highest quality measurement calibration, follow the suggestions below:

- use the correct standard model
- inspect the calibration standards
- clean the calibration standards
- gauge the calibration standards
- use correct connection techniques

If you want to use calibration standards other than the default sets, you must change the standard model (refer to “Modifying a standard” on page 13-9). After you enter the mathematical model for the new calibration standards, the analyzer can then use a model that corresponds to the new standards.

Procedures for Error-Correcting Measurements

This section has example procedures or information on the following topics:

E/E measurements

- Frequency response reflection calibration for E/E measurement 13-22
- Frequency response transmission calibration for E/E measurement 13-25
- One-port reflection calibration for E/E measurement 13-27
- Full two-port calibration for E/E measurement 13-30
- TRM* (TRL*) calibration for E/E measurement 13-33
- Interpolated error calibration for E/E measurement 13-34

E/O measurements

- Source response calibration for E/O measurement 13-37
- Source thru/receiver response calibration for E/O measurement 13-39
- Source response and match calibration for E/O measurement 13-41

O/E measurements

- Receiver response calibration for O/E measurement 13-43
- Receiver response and match calibration for O/E measurement 13-45

O/O measurements

- Calibration for Reflection O/O measurements 13-49
- Calibration for Transmission O/O measurements 13-51
- To define a reflector standard 13-53
- To define a thru standard 13-53

<p>NOTE</p>

<p>If you are making measurements on uncoupled measurement channels, you must make a correction for each channel.</p>

All calibration procedures assume you have set up the measurement parameters for the device-under-test.

Frequency response reflection calibration for E/E measurement

- 1 Press PRESET.
- 2 Select the type of measurement you want to make.
 - If you want to make a reflection measurement on PORT 1 (in the forward direction, S_{11}), leave the instrument default setting
 - If you want to make a reflection measurement on PORT 2 (in the reverse direction, S_{22}), press:
MEAS, Refl: E S22 REV
- 3 Set any other measurement parameters that you want for the device measurement: power, sweep type, number of points, HF bandwidth.
- 4 To access the measurement correction menus, press CAL.
- 5 If your calibration kit is not the 3.5mmD default, press:
CAL KITS & STDS
SELECT CAL KIT (select your type of kit)
RETURN, RETURN

If your type of calibration kit is not listed in the displayed menu, refer to “Modifying User-Defined Electrical Kits” on page 13-7.
- 6 Press CAL, *CALIBRATE MENU*.
- 7 If you plan to correct for isolation, press *RESPONSE & ISOL'N*.
- 8 Press *RESPONSE*.
- 9 Connect the short or open calibration standard to the port you selected for the test port (PORT 1 for S_{11} or PORT 2 for S_{22}).

Include any adapters that you will have in the device measurement. That is, connect the standard device to the particular connector where you will connect your device under test.

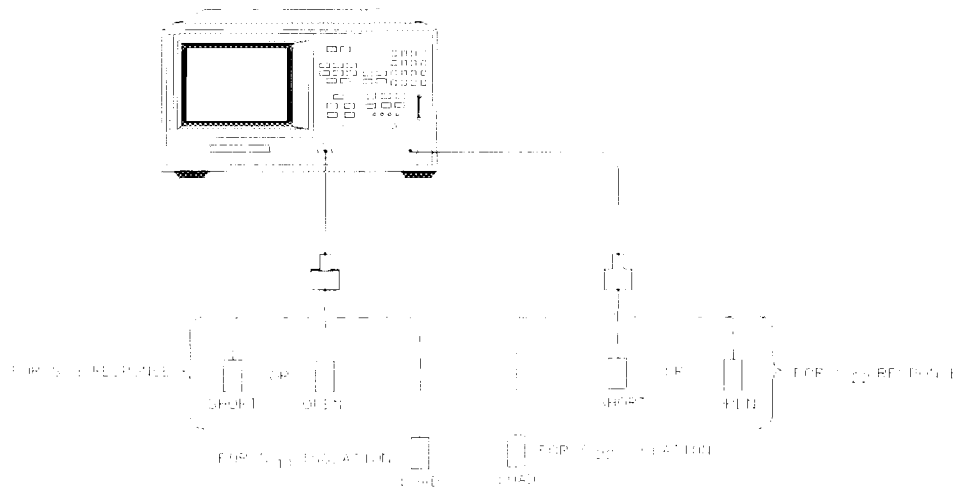

13-23

Figure 13-1. Standard Connections for a Response and Isolation Error-Correction for Reflection Measurements

- 10** To measure the standard, press *SHORT* or *OPEN*.

If the calibration kit you selected has a choice between male and female calibration standards, remember to select the sex that applies to the test port and not the standard.

The HP 8702D displays, *WAIT - MEASURING CAL STANDARD*, during the standard measurement. The HP 8702D beeps and underlines the softkey that you selected after it finishes the measurement.

Procedures for Error-Correcting Measurements

- 11** Do the following steps if you want to perform an isolation correction:
 - a** Connect the load calibration standard to the test port.
 - b** To measure the standard for the isolation portion of the correction, press *ISOL'N STD*.
 - c** To compute the response and directivity error coefficients, press *DONE RESP ISOL'N CAL*.

The HP 8702D displays the corrected S_{11} (or S_{22}) data. The HP 8702D also shows the notation *Cor* to the left of the screen, indicating that the correction is switched on for this channel.

- 12** This completes the response and isolation error-correction for reflection measurements. You can connect and measure your device under test.

Frequency response transmission calibration for E/E measurement

- 1 Press **PRESET**.
- 2 Select the type of measurement you want to make.
 - If you want to make a transmission measurement in the forward direction (S_{21}), press:
MEAS, Trans: E/E S21 FWD
 - If you want to make a transmission measurement in the reverse direction (S_{12}), press:
MEAS, Trans: E/E S12 REV
- 3 Set any other measurement parameters that you want for the device measurement: power, number of points, IF bandwidth.
- 4 Press **CAL**.
- 5 If your calibration kit is not the 3.5mmD default, press:
CAL KITS & STDS
SELECT CAL KIT: (select your type of kit)
RETURN, RETURN
- 6 Press **CALIBRATE MENU**.
- 7 If you plan to correct for isolation, press **RESPONSE & ISOL'N**.
- 8 Press **RESPONSE**.
- 9 Make a "thru" connection between the points where you will connect your device under test.

Include any adapters that you will have in the device measurement. That is, connect the standard device to the particular connector where you will connect your device under test.
- 10 To measure the standard, when the displayed trace has settled, press **THRU**.

The display shows the message **WAIT - MEASURING CAL STANDARD** during the standard measurement. The HP 8702D beeps and underlines the **THRU** soft-key after it measures the calibration standard.

Procedures for Error-Correcting Measurements

- 11** Do the following steps if you want to perform an isolation correction:
 - a** Connect impedance-matched loads to PORT 1 and PORT 2, as shown in Figure 13-2. Include the adapters that you would include for your device measurement.

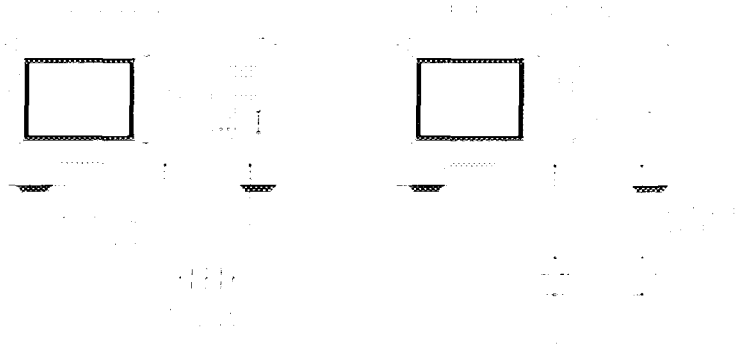

Figure 13-2. Standard Connections for a Response and Isolation Error-Correction for Transmission Measurements

If you will be measuring highly reflective devices, such as filters, use the test device, connected to the reference plane and terminated with a load, for the isolation standard.

- b** Press **AVG**, *AVERAGING ON*, *AVERAGING FACTOR* and enter at least four times more averages than desired during the device measurement.
- c** Press **CAL**, *MORE*, *ALTERNATE A AND B*.
- d** Press **CAL**, *RESUME CAL SEQUENCE*, *ISOL'N STD*.
- e** Return the averaging to the original state of the measurement.
- f** Press **CAL**, *RESUME CAL SEQUENCE*, *DONE RESP ISOL'N CAL*.

The display shows the corrected data trace and the notation **Cor** at the left of the screen, indicating that the correction is switched on for this channel.

- g** Connect and measure your device under test.

One-port reflection calibration for E/E measurement

- 1 Press PRESET.
- 2 The instrument normally makes an S_{11} measurement. However, if you want to make an S_{22} measurement, press:
MEAS, Refl: E S22 REV
- 3 Set any other measurement parameters that you want for the device measurement: power, number of points, IF bandwidth.
- 4 To access the measurement correction menus, press CAL.
- 5 If your calibration kit is not the 3.5mmD default, press:
CAL KITS & STDS
SELECT CAL KIT, CAL KIT: (select your type of kit)
RETURN, RETURN
- 6 To select the correction type, press:
CALIBRATE MENU and select the correction type:
 - To make a reflection measurement at PORT 1 press *S11 1-PORT*.
 - To make a reflection measurement at PORT 2, press *S22 1-PORT*.
- 7 Connect a shielded open circuit to PORT 1 (or PORT 2 for an S_{22} measurement).

NOTE

Include any adapters that you will have in the device measurement. That is, connect the calibration standard to the particular connector where you will connect your device under test.

Procedures for Error-Correcting Measurements



Figure 13-3. Standard Connections for a One Port Reflection Error-Correction

- 8 To measure the standard, when the displayed trace has settled, press *OPEN*.

NOTE

If the calibration kit that you selected has a choice between male or female calibration standards, remember to select the sex that applies to the test port and not the standard.

The HP 8702D displays, *WAIT - MEASURING CAL STANDARD*, during the standard measurement. The HP 8702D beeps and underlines the *OPEN* softkey after it measures the calibration standard.

- 9 Disconnect the open, and connect a short circuit to the test port.
- 10 To measure the standard when the displayed trace has settled, press *SHORT*.
The HP 8702D measures the short circuit, beeps, and underlines the *SHORT* softkey.
- 11 Disconnect the short, and connect an impedance-matched load to the test port.
- 12 When the displayed trace settles, press *LOAD*.
The HP 8702D measures the load, beeps, and underlines the *LOAD* softkey.

- 13** To compute the error coefficients, press:

DONE: 1-PORT CAL.

The HP 8702D displays the corrected data trace. The HP 8702D also shows the notation *Cor* to the left of the screen, indicating that the correction is switched on for this channel.

NOTE

The open, short, and load could be measured in any order, and need not follow the order in this example.

- 14** Connect and measure your device under test.

Full two-port calibration for E/E measurement

- 1 Set any measurement parameters that you want for the device measurement: power, format, number of points, IF bandwidth.
- 2 To access the measurement correction menus, press **CAL**.
- 3 If your calibration kit is not the 3.5mmD default, press:
CAL KITS & STDS
SELECT CAL KIT, CAL KIT: (select your type of kit)
RETURN, RETURN
- 4 To select the correction type, press:
CALIBRATE MENU, FULL 2-PORT, REFLECTION
- 5 Connect a shielded open circuit to PORT 1.

NOTE

Include any adapters that you will have in the device measurement. That is, connect the standard to the particular connector where you will connect your device under test.

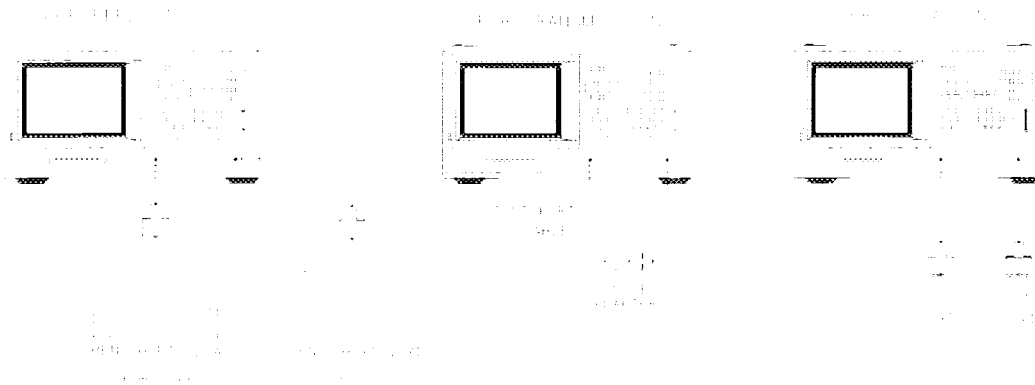

Figure 13-4. Standard Connections for Full Two Port Error-Correction

- 6** To measure the standard, when the displayed trace has settled, press *FORWARD: OPEN*.

The HP 8702D displays, *WAIT - MEASURING CAL STANDARD*, during the standard measurement. The HP 8702D beeps and underlines the *OPEN* softkey after it measures the standard.

- 7** Disconnect the open, and connect a short circuit to PORT 1.

- 8** To measure the device, when the displayed trace has settled, press *FORWARD: SHORT*.

The HP 8702D measures the short circuit, beeps, and underlines the *SHORT* softkey.

- 9** Disconnect the short, and connect an impedance-matched load to PORT 1.

- 10** To measure the standard, when the displayed trace has settled, press *FORWARD: LOAD*.

The HP 8702D measures the load, beeps, and underlines the *LOAD* softkey.

- 11** Repeat the open-short-load measurements described above, but connect the devices in turn to PORT 2, and use the *REVERSE: OPEN*, *REVERSE: SHORT*, and *REVERSE: LOAD* softkeys. Include any adapters that you would include in your device measurement.

- 12** To compute the reflection correction coefficients, press *STANDARDS DONE*.

- 13** To start the transmission portion of the correction, press *TRANSMISSION*.

- 14** Make a "thru" connection between the points where you will connect your device under test as shown in Figure 13-4 on page 13-30.

- 15** To measure the standard, when the trace has settled, press:

FWD TRANS THRU, *FWD MATCH THRU*, *REV TRANS THRU*, and *REV MATCH THRU*

The instrument beeps and underlines the softkey label after it makes each measurement.

- 16** To compute the transmission coefficients, press *STANDARDS DONE*.

- 17** Press *ISOLATION* and select from the following two options:

- a** If you will be measuring devices with a dynamic range less than 90 dB, press *OMIT ISOLATION*, *ISOLATION DONE*.

Procedures for Error-Correcting Measurements

b If you will be measuring devices with a dynamic range greater than 90 dB, follow these steps:

- Connect impedance-matched loads to PORT 1 and PORT 2. Include the adapters that you would include for your device measurement.
- If you will be measuring highly reflective devices, such as filters, use the test device, connected to the reference plane and terminated with a load, for the isolation standard.
- Activate at least four times more averages than desired during the device measurement.
- Press CAL, *RESUME CAL SEQUENCE, ISOLATION, FWD ISOL'N ISOL'N STD, REV ISOL'N ISOL'N STD, ISOLATION DONE.*
- Return the averaging to the original state of the measurement, and press CAL, *RESUME CAL SEQUENCE.*

18 To compute the error coefficients, press *DONE 2-PORT CAL.*

The HP 8702D displays the corrected measurement trace. The HP 8702D also shows the notation *COR* at the left of the screen, indicating that error correction is on.

19 Connect and measure your device under test.

TRM* (TRL*) calibration for E/E measurement

- 1** You must have a calibration kit defined. Refer to "Modifying a TRL* standard" on page 13-11.
- 2** Press *CAL, CAL KITS & STDS, SELECT CAL KIT, USER KIT, SAVE USER KIT, RETURN, RETURN, CALIBRATE MENU, TRL*/LRM* 2-PORT.*
- 3** To measure the "TRM THRU," connect the "zero length" transmission line between the two test ports.
- 4** To make the necessary four measurements, press:
THRU, FWD TRANS TRM THRU, FWD MATCH TRM THRU, REV TRANS TRM THRU, REV MATCH TRM THRU.
- 5** To measure the "TRM SHORT," connect the short to PORT 1, and press:
REFLECT AND LINE, FORWARD: TRM SHORT
- 6** Connect the short to PORT 2, and press:
REVERSE: TRM SHORT.
- 7** To measure the "TRM LOAD," connect the load to PORT 1, and press:
FORWARD: TRM LOAD, TRM LOAD.
- 8** Connect the load to PORT 2, and press:
REVERSE:TRM LOAD, TRM LOAD.
- 9** After the measurement is complete, press:
STANDARDS DONE.
- 10** To measure the "ISOLATION" class, press:
ISOLATION
- 11** Bypass the isolation measurement by pressing:
OMIT ISOLATION, ISOLATION DONE, DONE TRL 2-PORT.
- 12** Leave the load connected to PORT 2, and press:
REV ISOL'N ISOL'N STD.

Procedures for Error-Correcting Measurements

- 13** Connect the load to PORT 1, and press:

FWD ISOL'N ISOL'N STD.

You may repeat any of the steps above. There is no requirement to go in the order of steps. When the HP 8702D detects that you have made all the necessary measurements, the screen shows, PRESS 'DONE' IF FINISHED WITH CAL.

- 14** Press *DONE TRL 2-PORT.*

The message, COMPUTING CAL COEFFICIENTS, will appear, indicating that the HP 8702D is performing the numerical calculations of error coefficients.

- 15** Connect the device under test. The device S-parameters are now being measured.

Interpolated error calibration for E/E measurement

- 1** Press CAL, *INTERPOL ON.*

Source/Receiver Measurements

The procedures in this section measure and then normalize the response of the lightwave source or receiver. Use the source response procedure when you have a calibrated lightwave source to use as a standard device. Use the thru/receiver procedure when you don't have a calibrated source, but you do have a calibrated lightwave receiver to use as a standard.

Use the response and match procedure for greater accuracy in measuring with non-ideal electrical match. E/O and O/E response and match correction removes response errors of transmission measurement and port match errors, for example, source match error for E/O and load match error for O/E.

Perform isolation steps for added accuracy

Additional steps are provided in the correction procedures to correct for isolation errors. Isolation reduces the effect of crosstalk between the input and output ports. Although these added steps result in increased measurement accuracy, they take slightly longer to perform and are only useful when measuring optical losses greater than 35 dB. Also, you must decrease IF bandwidth and use a large amount of averaging to make analyzer sensitivity lower than the crosstalk.

First load the calibration data into the HP 8702D

HP 83400-series lightwave sources and receivers have calibration data which must be entered into the HP 8702D. The data is supplied on a disk and printed on a label. The most accurate data is contained on the disk. The calibration data for lightwave sources and receivers is supplied on a DOS-formatted disk which can be read using the front-panel disk drive, as well as a LIF-formatted disk. The HP 8702D reads both LIF and DOS-formatted disks. If both are available, use the DOS-formatted disk for better calibration results in log frequency mode. Use the LIF-formatted disk only if your receiver has not been recalibrated for use with DOS.

Refer to "Entering Calibration Kits and Standards" on page 13-4 to learn how to enter the calibration standard data.

The error-correction procedures in this chapter increase measurement accuracy by removing repeatable measurement variations from the test setup. Sources, receivers, interconnecting cables, and adapters all introduce variations in magnitude and phase that can mask the actual response of the device being tested. During an error-correction procedure, known standard devices are measured and the results compared to standard mathematical models stored in the HP 8702D's memory. These mathematical models are known as calibration kits.

Procedures for Error-Correcting Measurements

Each measurement channel has its own error corrections

An error-correction procedure can be performed for each measurement channel. If the two channels are stimulus coupled and the input ports are the same for both channels, they share the same correction data

Source response calibration for E/O measurement

- 1 Set up the stimulus and response parameters for the E/O measurement.
- 2 The calibration data for the lightwave source must be loaded into the internal memory of the HP 8702D. Refer to "Entering Calibration Kits and Standards" on page 13-4 for more information.
- 3 Press PRESET. Connect the standards as shown below.

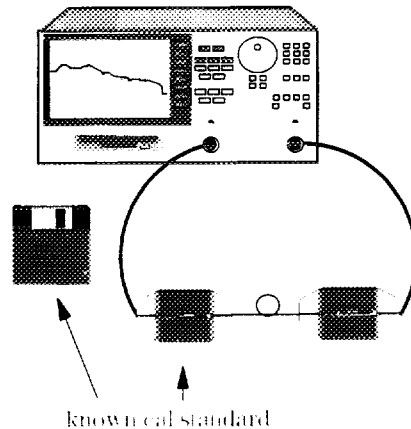

- 4 To access the measurement correction menus, press CAL, *CALIBRATE MENU*.
- 5 Press *RESPONSE*.
- 6 Select *DISK (1)*, or *(2)*, depending on which register was loaded with the calibration data for the source being used.
- 7 Save the calibration data by pressing, *SAVE/RECALL*, *SELECT DISK*, *INTERNAL MEMORY*, *RETURN*, *SAVE STATE*.
- 8 To return to the measurement mode, press MEAS.

The **Cor** label on the display indicates correction is turned on.

Response and isolation calibration

Perform the following steps if you want to correct for isolation.

- a To access the measurement correction menus, press CAL, *CALIBRATE MENU*.
- b To correct for isolation, press *RESPONSE & ISOL'N*.
- c Press *RESPONSE* and select the desired standard.

Procedures for Error-Correcting Measurements

- d Press *DONE RESPONSE*.
- e Disconnect the fiber-optic cable from the output connector of the source.
Do not aim the end of the cable at the input of the receiver.

WARNING

Do NOT, under any circumstances, look into the optical output, or any fiber/device attached to the output, while the laser is in operation.

- f Press *ISOL'N STD*. Wait for the measurement to finish.
 - g Press *DONE RESP ISOL'N CAL*.
- 9 This completes the thru/receiver response calibration. You can connect and measure your device-under-test as shown below.

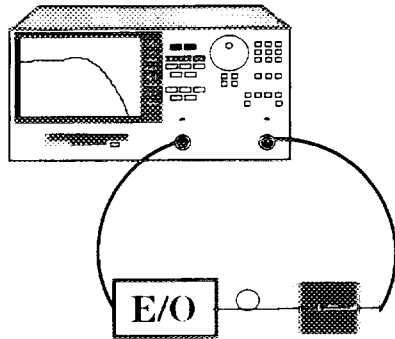

Source thru/receiver response calibration for E/O measurement

- 1 Set up the stimulus and response parameters for the E/O measurement.
- 2 The calibration data for the lightwave receiver must be loaded into the internal memory of the HP 8702D. Refer to "Entering Calibration Kits and Standards" on page 13-4 for more information.
- 3 To access the measurement correction menus, press *CAL, CALIBRATE MENU*.
- 4 Press *RESPONSE*.
- 5 Connect the RF thru as shown below.

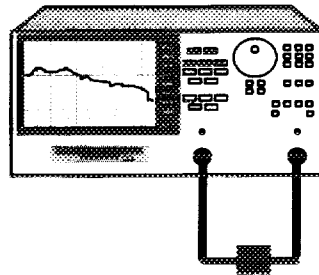

- 6 Insert the calibration disk for the lightwave receiver into the HP 8702D's front-panel disk drive.
- 7 Select either *DISK (1) THRU/RCVR* or *(2)* depending on which register was loaded with the calibration data for the receiver being used.
- 8 To save the calibration data, press: *SAVE/RECALL, SELECT DISK, INTERNAL MEMORY, RETURN, SAVE STATE*.

Response and isolation calibration

Perform the following steps if you want to correct for isolation.

- a To access the measurement correction menus, press *CAL, CALIBRATE MENU*.
- b To correct for isolation, press *RESPONSE & ISOL'N*.
- c Press *RESPONSE* and select the desired standard.

Procedures for Error-Correcting Measurements

- d Press *DONE RESPONSE*.
- e Disconnect the fiber-optic cable from the output connector of the source.
Do not aim the end of the cable at the input of the receiver.

WARNING

Do NOT, under any circumstances, look into the optical output, or any fiber/device attached to the output, while the laser is in operation.

- f Press *ISOL'N STD*. Wait for the measurement to finish.
 - g Press *DONE RESP ISOL'N CAL*.
- 9 This completes the thru/receiver response calibration. You can connect and measure your device-under-test as shown below.

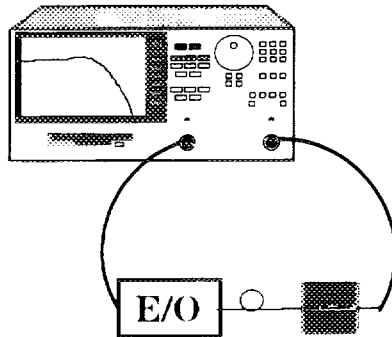

Source response and match calibration for E/O measurement

- 1 Set up the stimulus and response parameters for the E/O measurement.
- 2 The calibration data for the lightwave source must be loaded into the internal memory of the HP 8702D. Refer to "Entering Calibration Kits and Standards" on page 13-4 for more information.
- 3 To access the measurement correction menus, press *CAL*.
- 4 Select the RF calibration kit by pressing, *CAL KITS & STDS, SELECT CAL KIT*. The default selection is the 3.5 mm calibration kit (HP 85033D).
- 5 To select the response and match calibration, press *RETURN, RETURN, CALIBRATE MENU, RESPONSE AND MATCH*.
- 6 Connect the calibration standards as shown below. Press *REFLECTION*.

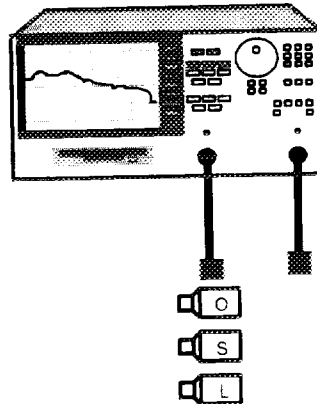

- 7 Connect an open to the cable on port 1, press *OPEN*.
- 8 Connect a short to the cable on port 1, press *SHORT*.
- 9 Connect a load to the cable on port 1, press *LOAD*.
- 10 Press *STANDARDS DONE*.

Procedures for Error-Correcting Measurements

- 11 Connect the standards as shown in the figure below. Press *TRANSMISSION*.

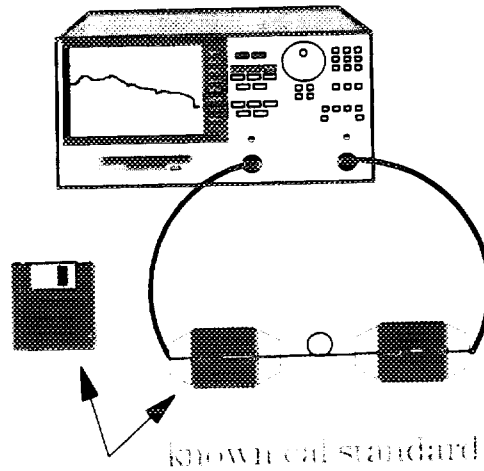

- 12 Press *FWD MATCH SOURCE, FWD TRANS SRC+RCVR*
- 13 Select the standard from *DISK (1)*, or *(2)*, depending on the source standard being used.
- 14 Press *DONE: SRC+RCVR*.
- 15 Press *STANDARDS DONE*.
- 16 To correct for isolation, press *ISOLATION*. To omit isolation, press *OMIT ISOLATION, DONE RESP&MATCH*.
- 17 If not omitting isolation, disconnect the fiber-optic cable from the output connector of the source. Do not aim the end of the cable at the input of the receiver.

WARNING

Do NOT, under any circumstances, look into the optical output, or any fiber/device attached to the output, while the laser is in operation.

- 18 If not omitting isolation, press *ISOL'N STANDARD*. Wait for the measurement to finish.
- 19 Press *DONE RESP & MATCH CAL*.
- 20 This completes the response and match calibration. You can connect and measure your device under test.

Receiver response calibration for O/E measurement

- 1 Set up the stimulus and response parameters for the O/E measurement.
- 2 The calibration data for the lightwave receiver must be loaded into the internal memory of the HP 8702D. Refer to "Entering Calibration Kits and Standards" on page 13-4 for more information.
- 3 To access the measurement correction menus, press *CAL, CALIBRATE MENU*.
- 4 Connect the standards as shown below: Press *RESPONSE*.

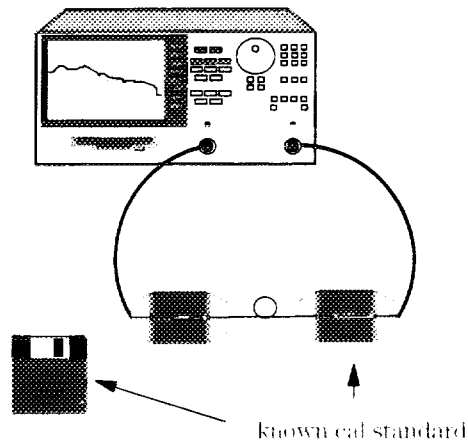

- 5 Select either *DISK (1)* or *(2)* depending on the required receiver standard.

Response and isolation calibration

Perform the following steps if you want to correct for isolation.

- 1 To access the measurement correction menus, press *CAL, CALIBRATE MENU*.
- 2 To correct for isolation, press *RESPONSE & ISOL'N*.
- 3 Press *RESPONSE* and select *DISK (1)* or *(2)*, depending on the receiver standard being used.
- 4 Press *DONE RESPONSE*.
- 5 Disconnect the fiber-optic cable from the output connector of the source. Do not aim the end of the cable at the input of the receiver.

WARNING

Do NOT, under any circumstances, look into the optical output, or any fiber/device attached to the output, while the laser is in operation.

- 6 Press *ISOL'N STANDARD*. Wait for the measurement to finish.
- 7 Press *DONE RESP & ISOL'N CAL*.
- 8 Save the calibration correction by pressing *SAVE/RECALL*.
- 9 This completes the response calibration. You can connect and measure your device-under-test as shown below.

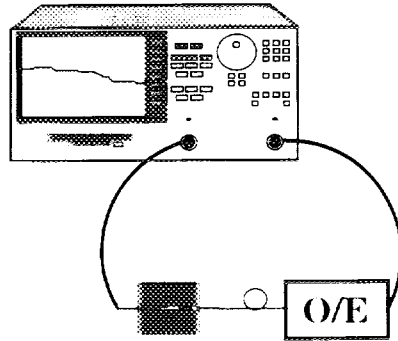

Receiver response and match calibration for O/E measurement

- 1 Set the stimulus and response parameters for an O/E response measurement.
- 2 The calibration data for the lightwave receiver must be loaded into the internal memory of the HP 8702D. Refer to "Entering Calibration Kits and Standards" on page 13-4 for more information.
- 3 To access the measurement correction menus, press CAL.
- 4 Select the RF calibration kit by pressing, *CAL KITS & STDS, SELECT CAL KIT*. The default selection is the 3.5 mm calibration kit (HP 85033D).
- 5 To select the response and match calibration, press *RETURN, RETURN, CALIBRATE MENU, RESPONSE & MATCH*.
- 6 Connect two RF cables as shown in the figure below. If an adapter is needed to mate the RF cables connect it to the cable on port 1. Press *REFLECTION*.

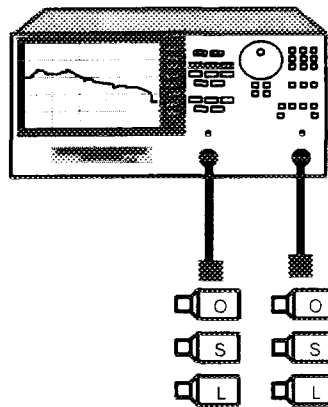

- 7 Connect an open to the cable on port 1, press *FORWARD OPEN*.
- 8 Connect a short to the cable on port 1, press *FORWARD SHORT*.
- 9 Connect a load to the cable on port 1, press *FORWARD LOAD*.
- 10 Connect an open to the cable on port 2, press *REVERSE OPEN*.
- 11 Connect a short to the cable on port 2, press *REVERSE SHORT*.
- 12 Connect a load to the cable on port 2, press *REVERSE LOAD*.

Procedures for Error-Correcting Measurements

- 13 Press *STANDARDS DONE*.
- 14 Connect two RF cables as shown in the figure below.

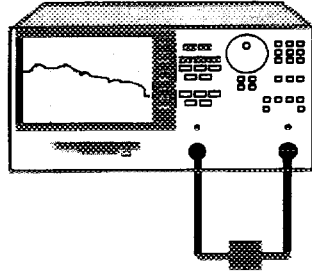

- 15 Press *FWD MATCH RF THRU*.
- 16 Connect two RF cables as shown in the figure below. If used, remove the adapter added in Step 6.

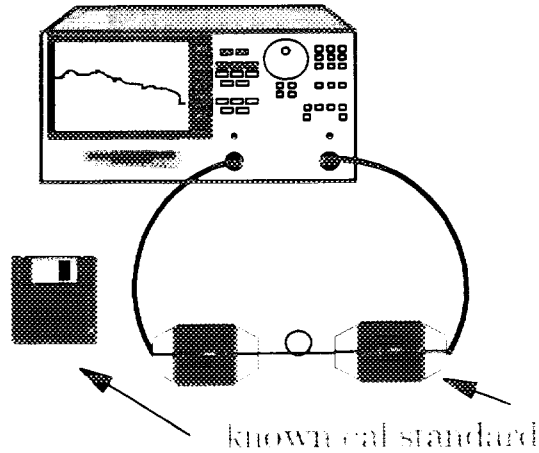

- 17 Press *FWD TRANS SRC+RCVR*.
- 18 Select *DISK (1)* or *(2)* depending on the receiver standard being used.
- 19 Press *DONE:SRC+RCVR, REV MATCH RECEIVER, STANDARDS DONE*.

Isolation calibration

Perform the following steps if you want to correct for isolation.

- a To correct for isolation, press *ISOLATION*. To omit isolation, press *OMIT ISOLA-*

TION, DONE RESP&MATCH.

b Disconnect the fiber-optic cable from the input connector of the receiver.

WARNING

Do NOT, under any circumstances, look into the optical output, or any fiber/device attached to the output, while the laser is in operation.

c Press *FWD ISOL'N ISOL'N STD.* Wait for the measurement to finish.

d Press *ISOLATION DONE, DONE RESP & MATCH.*

e Save the calibration correction information by pressing *SAVE/RECALL.*

20 This completes the response and match calibration. You can connect and measure your device under test.

Procedures for Error-Correcting Measurements

**Reflection/
Transmission
Measurement
Correction**

Two error-correction procedures are described in this section: one for reflection measurements and one transmission measurement. Each procedure removes the system's frequency response. Additional steps are provided to correct for isolation errors. Isolation reduces the effect of crosstalk between the input and output ports. Although these added steps result in increased measurement accuracy, they take slightly longer to perform and are only useful when measuring optical losses greater than 35 dB. Also, you must decrease IF bandwidth and use a large amount of averaging.

When performing error corrections for reflection measurements, you will need a reflector device defined in the standard menu. You can use the factory loaded calibration data (3.5% reflected power) for a Fresnel reflection if you do not connect an optical cable to the coupler's output. Otherwise, you must define your own reflector device.

After performing error corrections for transmission measurements, the measurement data is normalized setting the magnitude values to unity or 0 dB. The end of the through cable, connected to the receiver, is the measurement reference plane.

The error-correction procedures in this section increase measurement accuracy by removing repeatable measurement variations from the test setup. Sources, receivers, interconnecting cables, and adapters all introduce variations in magnitude and phase that can mask the actual response of the device being tested. During an error-correction procedure, known standard devices are measured and the results compared to standard mathematical models stored in the HP 8702D's memory. These mathematical models are known as calibration kits.

Procedures for Error-Correcting Measurements

- 8** Connect the device that you want to test.

Isolation calibration

Perform the following steps if you want to correct for isolation:

- a** Terminate the cable connected to the optical coupler output with a high return loss load. Refer to “Cleaning Connections for Accurate Measurements” on page 1-33 for more information.
 - b** Press *ISOL'N STD*, and wait for the measurement to complete.
 - c** Press *DONE RESPONSE ISOL'N CAL*.
- 9** Measure the device that you want to test.

Calibration for Transmission O/O measurements

- 1 Connect the equipment as shown in Figure 13-6.

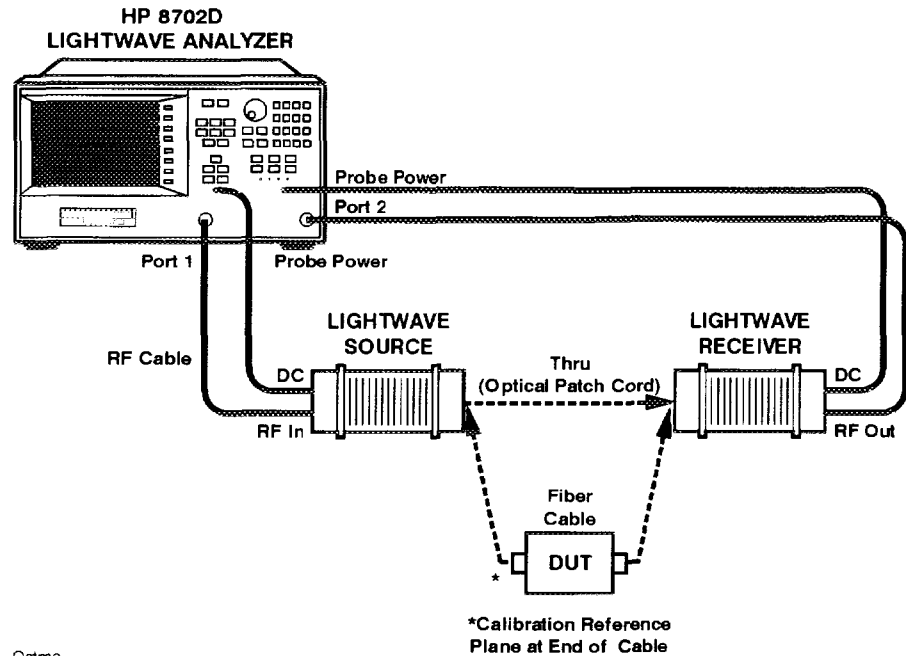

Figure 13-6. Transmission Measurement Test Setup

- 2 Configure the instrument's settings for the measurement.
- 3 Press MEAS, *LIGHTWAVE PARAMETERS*, *Trans: O/O (PORT 1→2)*.
- 4 If you are going to leave the "through" fiber-optic cable in the system during the measurement, continue with the next step. If however, the fiber-optic cable will be removed, you must define it so that it will be removed from the measurement calculation. Refer to "To define a thru standard" on page 13-53.
- 5 Press CAL, *CALIBRATE MENU*, *RESPONSE*, *THRU*.

When the measurement is completed, the word *RESPONSE* will be underlined.

Procedures for Error-Correcting Measurements

Isolation calibration

Perform the following steps if you want to correct for isolation:

- a Press *CAL, CALIBRATE MENU*.
- b Conduct the response portion of the calibration.
- c Disconnect the through fiber-optic cable from the receiver. Do not aim the end of the cable toward the receiver's input.

WARNING

Do NOT, under any circumstances, look into the optical output or any fiber/device attached to the output while the laser is in operation.

- d Press *RESPONSE & ISOL'N, ISOL'N STD*, and wait for the measurement to complete.
 - e Press *DONE RESP & ISOL'N CAL*.
- 6** Insert the device that you want to measure between the fiber-optic cable and the receiver's input.

Modifying Optical Standards

To define a reflector standard

- 1 Press *CAL*, *CAL KITS & STDS*, *OPTICAL STANDARDS*.
- 2 Select *MODIFY STANDARDS* or *MODIFY: FRESNEL*.
- 3 Select the following softkey to define the fiber-optic cable that is connected to the coupler's output and the reflector device:
 - Press *OFFSET LENGTH*, and enter the cable length in meters.
 - Press *OFFSET LOSS*, and entered the loss of the cable in dB/meter.
 - Press *OFFSET n*, and enter the refractive index.
 - Press *REFLECTED POWER*, and then enter the reflected power in percent.

If you don't know the percent of reflected power, press *REFLECTED POWER*, and then enter a value of 0. Then use the *OFFSET n* softkey to enter the index of refraction. The HP 8702D calculates the percent of reflected power.

- 4 Press *LABEL STD*, and enter a descriptive label. (A keyboard with a DIN interface may also be used to enter the label.)
- 5 Press *DONE*, and then *STD DONE (DEFINED)*, *DONE (MODIFIED)*.

To define a thru standard

- 1 Press *CAL*, *CAL KITS & STDS*, *OPTICAL STANDARDS*, *MODIFY STANDARDS*.
- 2 Press *MODIFY: THRU*.
- 3 Press *OFFSET LENGTH*, and enter the cable length in meters.
- 4 Press *OFFSET LOSS*, and enter the loss of the cable in dB/meter.
- 5 Press *OFFSET n*, and enter the refractive index.

Modifying Optical Standards

- 6 Press *LABEL STD*, and enter a descriptive label. (A keyboard with a DIN interface may also be used to enter the label.)
- 7 Press *DONE*, and then *STD DONE (DEFINED)*, *DONE (MODIFIED)*.

Calibrating with a Power Meter

You can use the power meter to monitor and correct the analyzer source power to achieve calibrated absolute power at the test port. You can also use this calibration to set a reference power for receiver power calibration, and mixer measurement calibration. The power meter can measure and correct power in two ways:

- continuous correction - each sweep mode
- sample-and-sweep correction - single sweep mode

Table 13-3. Typical Power Meter Calibration Sweep Speed and Accuracy

Power Desired at Test Port (dBm)	Number of Readings	Sweep Time (seconds) ^a	Typical Accuracy (dB) ^b
+5	1	33	±0.7
	2	64	±0.2
	3	95	±0.1
-15	1	48	±0.7
	2	92	±0.2
	3	123	±0.1
-30	1	194	±0.7
	2	360	±0.2
	3	447	±0.1

- a. Sweep speed applies to every sweep in continuous correction mode, and to the first sweep in sample-and-sweep mode. Subsequent sweeps in sample-and-sweep mode will be much faster.
- b. The accuracy values were derived by combining the accuracy of the power meter and linearity of the analyzer's internal source, as well as the mismatch uncertainty associated with the power sensor.

Calibrating with a Power Meter

The power correction data will be lost if any of the following circumstances exists.

- If you switch off the analyzer ac power and you haven't saved the correction in an internal register.
- If you change the sweep type (linear, log, list, CW, power) when the power meter correction is activated.
- If you change the frequency when the sweep type is in log or list mode.
- If you press PRESET and you haven't saved the correction in an internal register.

Entering power sensor calibration data

- 1** Make sure that your analyzer and power meter are configured.
- 2** Press *CAL*, *PWRMTR CAL*, *LOSS/SENSR LISTS*, *CAL FACTOR SENSOR A*.
The analyzer shows the notation, *EMPTY*, if you have not entered any segment information.
- 3** To create the first segment, press: *ADD*, *FREQUENCY*.
- 4** Enter the frequency of a correction factor data point, followed by the appropriate key: *G/n*, *M μ* , *k/m*.
- 5** Press *CAL FACTOR* and enter the correction factor that corresponds to the frequency that you have entered in the previous step. Complete the correction factor entry by pressing: *x1*, *DONE*.
- 6** Repeat the previous two steps to enter up to twelve frequency segments.
You may enter multiple segments in any order because the analyzer automatically sorts them and lists them on the display by frequency value.
If you only enter one frequency segment, the analyzer assumes that the single value is valid over the entire frequency range of the correction.
- 7** After you have entered all the frequency segments, press: *DONE*.

Editing frequency segments

- 1** Identify the segment that you want to edit:
 - If you are already in the "Segment Modify Menu," press *SEGMENT*.
 - If you are not in the "Segment Modify Menu," press *CAL*, *PWRMTR CAL*, *LOSS/SENSR LISTS*, *CAL FACTOR SENSOR A* (or *CAL FACTOR SENSOR B*, depending on where the segment is that you want to edit), and then press *SEGMENT*.
- 2** Press the \uparrow and \downarrow keys to position the segment that you want to edit next to the pointer ($>$), shown on the display.
- 3** Press *EDIT* and then press either the *FREQUENCY* or *CAL FACTOR* key, depending of which part of the segment you want to edit.
 - If you are modifying the frequency, enter the new value, followed by a G/n, M/ μ , or k/m key.
 - If you are modifying the correction factor, enter the new value, followed by the x1 key.
- 4** Press *DONE* after you have finished modifying the segment.
- 5** If you want to edit any other segments, press *SEGMENT* and follow the previous steps, starting with Step 2.

Deleting frequency segments

- 1** Identify the segment that you want to delete:
 - If you are already in the "Segment Modify Menu," press *SEGMENT*.
 - If you are not in the "Segment Modify Menu," press *CAL*, *PWRMTR CAL*, *LOSS/SENSR LISTS*, *CAL FACTOR SENSOR A* (or *CAL FACTOR SENSOR B*, depending on where the segment is that you want to delete), and then *SEGMENT*.
- 2** Press the \uparrow and \downarrow keys to position the segment that you want to delete next to the pointer ($>$), shown on the display.
- 3** Press *DELETE*.

The analyzer deletes the segment and moves the remainder of the segments up one number.
- 4** You could also delete all the segments in a list by pressing *CLEAR LIST*.
- 5** Press *DONE* when you are finished modifying the segment list.

Compensating for directional coupler response

If you use a directional coupler to sample power in your measurement configuration, you should enter the coupled arm power loss value into the power loss table, using the following procedure. You can enter the loss information in a single segment, and the analyzer will assume that the value applies to the entire frequency range of the instrument. Or, you can input actual measured power loss values at several frequencies using up to 12 segments, enhancing power accuracy.

- 1 Press *CAL*, *PWRMTR CAL*, *LOSS/SENSR LISTS*, *POWER LOSS*.

The analyzer shows the notation *EMPTY*, if you have not entered any segment information.

- 2 To create the first segment, press *ADD*, *FREQUENCY* and enter a frequency of a correction factor data point, followed by the appropriate key: *G/n*, *Mμ*, *k/m*.
- 3 Press *LOSS* and enter the power loss that corresponds to the attenuation of the power splitter or directional coupler at the frequency that you have entered in the previous step. Complete the power loss entry by pressing: *x1*, *DONE*.

Remember to subtract the through arm loss from the coupler arm loss before entering it into the power loss table, to ensure the correct power at the output of the coupler.

- 4 Repeat the previous two steps to enter up to twelve frequency segments, depending on the required accuracy.

You may enter multiple segments in any order because the analyzer automatically sorts them and lists them on the display in increasing order of frequency.

If you only enter one frequency segment, the analyzer assumes that the single value is valid over the entire frequency range of the correction.

- 5 After you have entered all the segments, press *DONE*, *DONE*.
- 6 Press *RETURN*, *PWR LOSS ON* to activate the power loss compensation.

Using sample-and-sweep correction mode

You can use the sample-and-sweep mode to correct the analyzer output power and update the power meter correction data table, during the initial measurement sweep. In this mode of operation, the analyzer does not require the power meter for subsequent sweeps. Therefore, this mode sweeps considerably faster than the continuous correction mode.

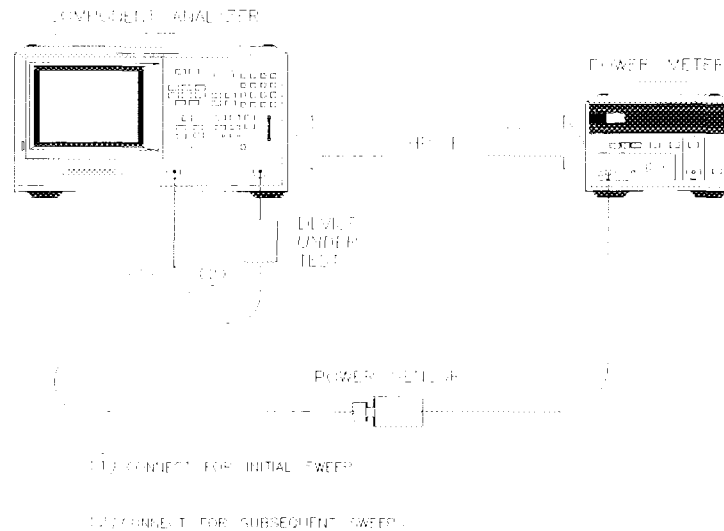

Figure 13-7. Sample-and-Sweep Mode for Power Meter Calibration

- 1 Connect the equipment as shown in Figure 13-7.
- 2 Set test port power to the approximate desired corrected power by pressing, **CAL**, **PWRMTR CAL** and enter the test port power level that you want at the input to your test device.
- 3 If you want the analyzer to make more than one power measurement at each frequency data point, press:
NUMBER OF READINGS n , $x1$ (where n = the number of desired iterations).
If you increase the number of readings, the power meter correction time will substantially increase.
- 4 Press **ONE SWEEP, TAKE CAL SWEEP**.

Calibrating with a Power Meter

With the initial sweep, the analyzer measures the actual power at each frequency point.

The measurement sweep time will increase significantly during the initial sweep.

The analyzer will use the data table for subsequent sweeps to correct the output power level at each measurement point. Also, the status annunciator *PC* will appear on the analyzer display.

You can abort the calibration sweep by pressing: *PWRMTR CAL OFF*.

- 5** Remove the power sensor from the analyzer test port and connect your test device.

Using continuous correction mode

You can set the analyzer to update the correction table at each sweep (as in a leveling application), using the continuous sample mode. When the analyzer is in this mode, it continuously checks power at every point in each sweep. You must keep the power meter connected as shown in Figure 13-8. This mode is also known as power meter leveling, and the speed is limited by the power meter.

You may level at the output of a device under test, using a power splitter before the device, or a directional coupler after the device.

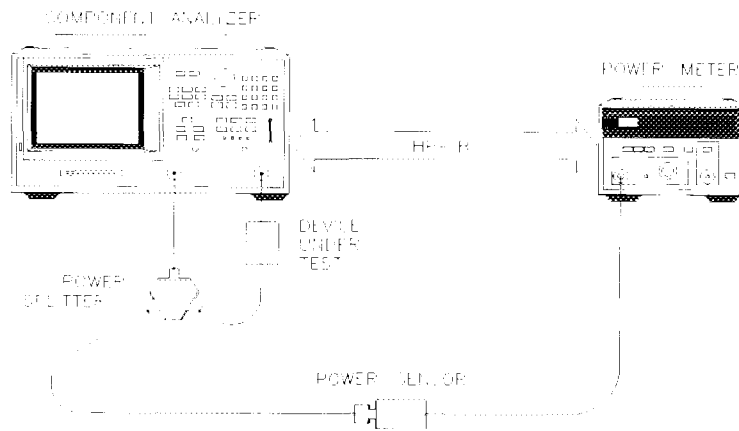

Figure 13-8. Continuous Correction Mode for Power Meter Calibration

Calibrating with a Power Meter

- 1** Connect a power splitter or directional coupler to the RF power that you are applying to your test device, as shown in Figure 13-8
- 2** Set test port power to approximate desired leveled power.
- 3** Press *CAL*, *PWRMTR CAL* and enter the test port power level that you want the analyzer to maintain at the input to your test device. Compensate for the power loss of the power splitter or directional coupler in the setup.
- 4** If you want the analyzer to make more than one power measurement at each frequency data point, press *NUMBER OF READINGS* n , $x1$ (where n = the number of desired iterations).

If you increase the number of readings, the power meter correction time will substantially increase.

- 5** Press *EACH SWEEP* to activate the power meter correction. To abort the process, press *PWRMTR CAL OFF*.

Calibrating the HP 8702D to measure absolute power

You can use the power meter calibration as a reference to calibrate the analyzer receiver to accurately measure absolute power. The following procedure shows you how to calibrate the receiver to 0 dBm.

- 1** To set the analyzer test port power to 0 dBm, press:

MENU, *POWER*, 0, x1

- 2** Connect the power sensor to the analyzer test port 1.

- 3** To apply the one sweep mode, press:

CAL, *PWRMTR CAL*, *ONE SWEEP*, *TAKE CAL SWEEP*

The status notation, *PC*, will appear on the analyzer display.

- 4** Connect the 0 dBm test port 1 output to the test port 2 input.

- 5** Choose a non-ratioed measurement by pressing:

MEAS, *INPUT PORTS*, *B*, *TEST PORT 1*

This sets the source at PORT 1, and the measurement receiver to PORT 2, or B channel.

- 6** To perform a response error-correction, press:

CAL, *CALIBRATE MENU*, *RESPONSE*, *THRU*

The receiver channel now measures power to a typical accuracy of 0.35 dB or better. The accuracy depends on the match of the power meter, the source, and the receiver.

Index

Numerics

3 dB bandwidth measurement, 7-35

A

absolute power calibration, 13-65

accessories, static-safe, 1-32

accuracy

enhancement, 13-21

frequency drift, 6-10

harmonic mode, 4-44

input power, 6-49

interconnecting cables, 6-9

measurement, 6-9, 13-35

mixer testing, 4-47, 4-50

temperature drift, 6-10

activating

fixed markers, 7-22

markers, 7-9

active

channel keys, 1-5

marker, 7-9

adapters, 4-63

adding calibration data, 13-35

addressing sources, 8-15

adjusting

display colors, 6-7

trace display, 5-32

admittance measurement with markers, 7-44

alias span, 5-32

alternate sweep mode, 1-29

amplifier gain compression, 4-33

amplifier testing, 4-31, 4-34

parameters, 4-31

power level metering, 4-34

amplitude

response, 4-5

tracking, 7-27

tracking, mixer testing, 4-56

analyzer display, 1-7

aperature

frequency variations, 4-14

specifying, 4-19

applications

amplifier testing, 4-31, 4-34

arrays, saving, 9-7

attenuation

at mixer ports, 8-3

mixer testing, 4-48

attenuator switch protection, 1-24

auto sweep time mode, setting, 6-27

averaging, 6-33

factor, widening, 6-28

B

bandwidth

measurement using markers, 7-35

system, widening, 6-27

beating response, 5-13

brightness, changing display, 6-7

bus pin location (GPIO mode), 11-8

bytes allowed in sequencing, 11-6

C

cable

interconnecting, 6-9

multimode, 5-27

reflection measurement, 5-9

cable optical, 2-2

measuring length, 5-16

reflection measurement, 3-9

transmission measurement, 5-5

calculate statistics of data, 7-29

calibration

adding data, 13-35

entering coefficients, 13-5

entering factors, 13-57

for mixer measurements, 8-34

kits, 13-2-13-65

specifying kits, 13-6

standards, 13-20

care of fiber optics, iii

center frequency set with markers, 7-15

changing

display format, 6-12

sequence title, 11-22

sweep speed, 2-2

channel

active keys, 1-5

coupling, 4-41

error correction, 13-36

power coupling, 1-23

power coupling, harmonic operation, 6-48

-
- power, decoupled, 6-5
 - viewing, 6-23
 - channel 1 and 2 ratio measurement, 6-24
 - characterizing devices, iv
 - chop sweep mode, 1-29
 - activating, 6-29
 - cleaning
 - adapters, 1-38
 - fiber-optic connections, 1-33, 1-37
 - non-lensed connectors, 1-37
 - clearing sequences from memory, 11-22
 - cleave measurement, 5-21
 - coefficient
 - entering, 13-5
 - reflection, 2-9
 - reflection measurement with markers, 7-38
 - colors
 - adjusting display, 6-7
 - changing display, 6-7
 - recalling modified, 6-8
 - saving modified, 6-8
 - compensating for directional coupler response, 13-60
 - component analyzer mode, 6-38
 - compressed dust remover, 1-35
 - compression measurement, 4-36
 - configuring sources, 8-15
 - connecting peripherals, 12-17
 - connections
 - adapters, 4-63
 - fixtures, 4-64
 - connector
 - care, 1-33
 - care manual, 1-40
 - characterizing, 1-39
 - for external monitor, 1-9
 - for HP-IB, 1-9
 - front panel, 1-5-1-6
 - R channel, 1-6
 - rear panel, 1-9-1-10
 - repeatability, 6-9
 - considerations for mixer measurements, 8-3
 - constant group delay, 4-11
 - continuous
 - correction mode for power meter calibration, 13-63
 - markers, selecting, 7-10
 - conversion compression
 - mixer measurement, 8-23
 - mixer testing, 8-55
 - swept power, 8-27
 - conversion loss
 - mixer testing, 8-51
 - procedure, 8-11
 - using the frequency offset mode, 8-4
 - using tuned receiver mode, 8-14-8-15
 - Corr/C? annotation, 4-40
 - correcting isolation errors, 13-35
 - correction, 13-21
 - types, 13-18
 - cotton swabs, 1-35
 - coupled marker, 7-11
 - coupling
 - channel power, 1-23
 - channels, 4-11
 - port power, 1-23
 - power, 1-23, 4-13
 - power between channels, 6-48
 - creating
 - sequences, 11-12
 - creating a link, 11-16
 - crosstalk, reducing, 4-30, 6-32, 6-37
 - CW frequency setting with markers, 7-18
 - CW time sweep, 1-29
- ## D
- data
 - array, saving, 9-7
 - divided by memory, 6-24
 - front panel entry, 1-5
 - saving, 9-9
 - statistics, 7-39
 - data and memory viewing, 6-24
 - data trace
 - defined, 6-4
 - saved to the display memory, 6-23
 - decision making functions in sequencing, 11-8
 - decoupled channel/port power, 6-5
 - decrease frequency span, 6-27
 - default
 - colors, setting, 6-8
 - display colors, 6-7
 - filenames, 9-10, 12-4
 - frequency range, Option 006, 5-21
 - plotter pen numbers, 12-13
-

- plotting values, 12-9
- printing values, 12-8
- settings, 1-13
- defined plotting components, 12-12
- deleting commands in sequencing, 11-14
- delta marker
 - displaying, 7-21
 - menu, 7-5
- designing fixtures, 4-64
- deviation from linear phase, 4-9
- device, characterizing, iv
- directional coupler compensation, 13-60
- discrete markers, selecting, 7-10
- disk
 - format, 13-35
 - formatting, 9-11
 - storage problems, 9-12
- disk drive, 1-6
 - connecting, 12-17
- disk file, saving data, 9-7
- display, 1-5, 1-7
 - color, 6-7
 - dual channel, 4-40, 6-5
 - features, 1-7
 - format, iv
 - functions, 6-4
 - marker, displaying, 7-11
 - memory, 6-5
 - memory trace, 6-23
 - polar/Smith chart, 7-30
 - reference, setting with markers, 7-17
 - saving to a file, 9-10
 - split view, 6-5
 - trace math, 6-24
 - viewing both channels, 6-5
- display format
 - changing, 6-12
 - data array, saving, 9-7
 - group delay, 6-15
 - imaginary, 6-20
 - linear magnitude, 6-18
 - log magnitude, 6-13
 - phase, 6-14
 - polar, 6-17
 - real, 6-20
 - selecting, 6-20
 - Smith chart, 6-16
 - SWR, 6-19
- displaying
 - delta markers, 7-21
 - list of values, 12-7
 - markers, 7-10
 - traces, 6-21
- distortion measurement, 3-11
- divide data by the memory trace, 6-24
- DOS
 - filenames, 12-4
 - format, 13-4
 - format, saving, 9-7-9-11
 - formatting disk, 13-35
- down conversion, mixer testing, 4-50
- drift
 - frequency, 6-10
 - temperature, 6-10
- dry connections, 1-34
- dual channel
 - display, 4-40, 6-21, 6-23
 - mode, 6-5
 - operation, 6-48
 - operation, harmonic mode, 4-42
 - problems with, 6-5
- dust caps, 1-35
- dynamic range, 3-12
 - increasing, 2-2, 6-30

E

- E/E device measurement, 4-2-4-64
 - frequency response reflection, 13-22
 - frequency response transmission, 13-25
 - full two-port calibration, 13-30
 - interpolated error calibration, 13-34
 - one-port reflection, 13-27
 - TRM* (TRL*), 13-33
- E/O converter, modulation transfer, 2-5
- E/O device measurement, 2-4-2-13
 - source response, 13-37
 - source response and match, 13-41
 - source thru response, 13-39
- edit
 - limits menu, 10-5
 - mode, sequencing, 11-5
 - segment menu, 10-6
- editing
 - sequences, 11-12
 - test sequences, 11-5

-
- electrical delay, 4-15
 - adding, 4-9, 4-17
 - setting with markers, 7-19
 - vs. port extension, 6-11
 - electrical kits, user-defined, 13-7
 - electrical length, measuring, 3-15, 4-16
 - electrical reflection measurement, 2-9
 - electrical signal separation, 2-9
 - electro-optical devices
 - measuring, 2-2, 3-2
 - entering coefficients, 13-5
 - entry block, 1-5
 - error-correction, 6-9, 13-21
 - calibration standards, 13-20
 - characteristics affected, 13-17
 - interpolated, 13-34
 - measurement channel, 13-36
 - performing, 2-2, 3-2, 4-2, 13-13-13-54
 - reflection measurements, 13-49
 - saving data array, 9-7
 - transmission measurements, 13-51
 - types, 13-18
 - errors, removing, 13-18
 - ESD (electrostatic discharge), 1-31
 - reducing damage caused by ESD, 1-32
 - static-safe work station, 1-32
 - EXT MON connector, 1-9
 - external source mode, 6-39
 - applications, 6-39
 - auto, 6-40
 - capture range, 6-41
 - CW frequency range, 6-40
 - description, 6-40
 - frequency modulation, 6-41
 - manual, 6-40
 - requirements, 6-41
 - sweep types, 6-40
 - test setup, 6-39
- F**
- factory default settings, 1-13
 - faster sweep speed, 6-25
 - feedthrough
 - mixer testing, 4-52
 - RF, 8-31
 - fiber cable
 - optical reflection, 5-9
 - fiber optics
 - care of, iii
 - cleaning connections, 1-33
 - inspecting, 1-35
 - fiber optic cable
 - measurement, 5-5
 - sweep time, 5-15
 - file
 - deleting, 9-5
 - extension for plotting, 12-4
 - renaming, 9-5
 - filenames, default, 9-10, 12-4
 - filtering
 - mixer testing, 4-47
 - mixers, 8-3
 - fixed IF mixer measurement, 8-14, 8-19
 - fixed marker, 7-5
 - activating, 7-22
 - fixtures, 4-64
 - flat limit lines, 10-10
 - foam swabs, 1-35
 - format
 - array, saving, 9-7
 - changing display, 6-12
 - display, iv
 - format markers
 - polar, 7-31
 - Smith chart, 7-32
 - formatting a disk, 9-11
 - forward measurement, 4-40
 - Fourier inverse transform, 4-22
 - frequency
 - accuracy, mixer testing, 4-50
 - aperture variations, 4-14
 - domain measurement, 4-22
 - drift, 6-10
 - list sweep, setting, 8-15
 - spacing between points, 4-19
 - stability, mixer testing, 4-50
 - frequency offset, 8-5
 - applications, 6-14
 - conversion compression, 8-23
 - description, 6-15
 - mixer testing, 4-54
 - operation, 6-14
 - test setup, 6-15
 - frequency range, 6-48
 - defining, 1-21
-

- harmonic mode, 4-43
 - Option 006 default, 5-21
- frequency response
 - domain reflection, 4-28
 - measurement calibration, 13-14
 - measurement correction, 4-16
 - reflection calibration, 13-22
 - transmission calibration, 13-25
- frequency selection
 - mixers, 4-49, 8-3
- frequency span
 - reducing, 4-6, 6-27
 - setting with markers, 7-16
- Fresnel reflection, 5-11, 5-18, 13-4
 - defining, 13-53
- front panel
 - connectors, 1-5-1-6
 - features, 1-4
- full two-port
 - calibration, 13-30
 - error correction, 13-15

G

- gain
 - compression measurement, 4-36
 - compression, amplifier, 4-33
 - measurement, 4-40
- gate characteristics, 4-25-4-26
- gate settings, 4-25
- gating, effects in frequency domain, 4-23
- gosub sequence command, 11-4, 11-6
- GPIO mode, 11-7
- GPIO sequence mode, 11-4
- group delay, 3-11, 4-9, 4-11
 - display format, 6-15
 - measurement, 4-19
 - mixer measurements, 8-20
 - mixer testing, 4-57
- guided setup, 1-2, 5-10
 - measurements, 1-15

H

- H=2/H=3 display annotation, 6-48
- harmonic mode
 - accuracy, 4-44
 - dual channel operation, 4-42

- frequency range, 4-43
- input power, 4-44
- measurements, 4-42
- single-channel operation, 4-42
- harmonic operation, 6-47
 - accuracy, 6-49
 - coupling channel power, 6-48
 - dual-channel, 6-48
 - frequency range, 6-48
 - input power, 6-49
 - single-channel, 6-47
 - test setup, 6-47
- help screen for sequencing, 11-13
- high dynamic range
 - swept RF/IF conversion loss, 8-11
- higher order phase shift, 4-12
- HP-GL
 - compatible printers/plotters, 12-2
 - format for printing/plotting, 12-2
 - graphics format, 9-10
 - sequencing, 11-10
- HP-IB
 - entering sequences, 11-11
 - reading sequences, 11-11
 - saving measurement data, 9-7
 - status, 1-5

I

- IEC Publication 1010, v
- IF bandwidth, 6-35
 - widening, 6-27
- IF mixer measurement, fixed, 8-19
- imaginary
 - display format, 6-20
 - or real display format, iv
- impedance measurement, 7-42
 - with markers, 7-42
- improving resolution, 3-16
- impulse response, 5-24
- inactive marker, 7-9
- incident signal pulse width, 5-29
- increasing
 - dynamic range, 2-2, 6-30
 - measurement accuracy, 6-9
 - scale resolution, 4-18
 - sweep speed, 6-25, 13-65
 - test port power, 6-30

-
- index of refraction, 5-17
 - index-matching compounds, 1-34
 - input
 - connector, 1-33
 - ports, 1-5
 - power accuracy, 6-49
 - power, harmonic mode, 4-44
 - inserting commands for sequencing, 11-14
 - insertion loss connectors, 1-39
 - insertion phase response, measuring, 4-4
 - inspecting
 - cables, 1-35
 - visual, 1-36
 - instrument display, 1-5
 - instrument modes, 6-38
 - component analyzer, 6-38
 - external source, 6-39
 - frequency offset, 6-44
 - harmonic, 6-47
 - tuned receiver, 6-42
 - instrument state, 10-6
 - contents, 9-4
 - defined, 6-4
 - function block, 1-5
 - storing, 9-5
 - interconnecting cables, 6-9
 - internal memory, saving data, 9-7
 - interpolated error calibration, 13-34
 - interpolated error correction, 1-29, 13-17
 - inverse Fourier transform, 4-22
 - isolation
 - correcting, 13-35
 - measurement, 4-40
 - measurements for mixers, 8-28
 - mixer testing, 4-52
 - isopropyl alcohol, 1-35
- L**
- label HP-IB command, 11-10
 - length, measuring a single-mode cable, 5-16
 - LIF
 - filenames, 12-4
 - format, 13-4
 - format, saving, 9-7-9-11
 - formatting disk, 13-35
 - limit lines, 10-2-10-16
 - limit segments, editing, 10-6
 - limit test decision making, 11-9
 - limit testing, 10-6
 - creating flat limit lines, 10-10
 - creating single point limits, 10-15
 - creating sloping limit lines, 10-13
 - limits
 - editing, 10-5
 - offset, 10-6
 - LIN MKR, 7-31
 - line switch, 1-4
 - linear
 - frequency sweep, 1-27
 - magnitude display format, 6-18
 - phase, 3-11
 - linearly changing phase, 4-17
 - link, creating in sequencing, 11-16
 - list frequency sweep, 1-27
 - list of values, displaying, 12-7
 - LO feedthru, mixer testing, 4-52
 - LO to RF isolation for mixers, 8-29
 - log magnitude display format, 6-13
 - LOG MKR, 7-31
 - logarithmic
 - frequency sweep, 1-27
 - magnitude display format, iv
 - loop counter
 - building in sequences, 11-17
 - decision making in sequencing, 11-9
 - in sequencing, 11-6
 - initializing, 8-15
 - lossless transmission line, 4-15
 - low pass impulse, 5-24
 - lowering output power, 4-40
- M**
- macros *See* sequences
 - magnitude response
 - correcting variations, 13-35
 - measuring, 4-4
 - making relative measurements, 7-20
 - marker
 - active/inactive, 7-9
 - couple/uncouple display, 7-11
 - displaying, 7-10
 - selecting continuous/discrete, 7-10
 - statistical measurements, 7-28
 - turning off, 7-10
-

marker menu, 7-5
 marker mode menu, 7-6-7-7
 marker offset menu, 7-5
 marker search menu, 7-7
 markers
 activating, 7-9
 calculate data statistics, 7-29
 delta, 7-21
 fixed reference, 7-5
 LIN MKR, 7-31
 LOG MKR, 7-31
 measuring bandwidth, 7-35
 polar format, 7-31
 Re/Im MKR, 7-31
 search for bandwidth, 7-26
 search for target amplitude, 7-25
 searching for minimum/maximum values, 7-24
 searching with, 7-24
 set center frequency, 7-15
 set CW frequency, 7-18
 set display reference, 7-17
 set electrical delay, 7-19
 set frequency span, 7-16
 set start/stop frequency, 7-13
 Smith chart markers, 7-32
 Smith or polar format, 7-22-7-23
 trace deviation, 4-18
 tracking amplitude, 7-27
 using, 7-4
 math with data traces, 6-24
 maximum amplitude of response, 4-5
 measurement
 accuracy, iii
 cable optical transmission, 5-5
 data, saving, 9-9
 electrical length, 3-15, 4-16
 electrical reflection, 2-9
 electro-optical, 2-2
 electro-optical devices, 3-2
 frequency domain, 4-22
 gain and reverse isolation, 4-40
 gain compression, 4-36
 group delay, 4-19
 guided setup, 1-15
 harmonic, 4-42
 insertion phase response, 4-4
 magnitude response, 4-4
 manual, source, 2-2
 mixer, 8-1-8-36
 modulation, transfer of a source, 2-5
 on-wafer, 4-62
 optical reflection, 3-9, 5-9
 peak response, 4-24
 phase distortion, 3-11, 4-18
 points, reducing, 6-28
 printing and plotting, 12-2-12-23
 pulse dispersion on multimode cable, 5-27
 range, setting, 7-12
 receiver, 3-5
 reference plane, 5-18
 reflection, 2-8, 3-8, 5-8
 reflection response, 4-27
 relative, 7-20
 response, 13-35
 saving data, 9-7
 source, 2-2, 2-5
 statistical, 7-28
 swept power, 4-35
 time domain, 4-22, 5-14-5-34
 transmission, 2-4, 3-4, 5-4
 transmission response in time domain, 4-24
 measurement accuracy, 13-35
 calibration standards, 13-20
 compensating for directional coupler response, 13-60
 connector repeatability, 6-9
 frequency drift, 6-10
 increasing, 6-9
 interconnecting cables, 6-9
 performance verification, 6-10
 reference plane and port extensions, 6-11
 temperature drift, 6-10
 measuring bandwidth, 7-35
 memory trace, 6-23
 data, saving, 9-7
 defined, 6-4
 saving, 9-9
 memory, clearing sequences, 11-22
 minimum/maximum values
 searching with markers, 7-24
 mixer
 isolation measurement, 8-29
 measurements, 8-1-8-36
 mixer testing, 4-46
 accuracy, 4-47

- amplitude and phase tracking, 4-56
- attenuation, 4-48
- conversion compression, 4-55
- conversion loss, 4-51
- down conversion, 4-50
- filtering, 4-47
- frequency accuracy, 4-50
- frequency offset mode, 4-54
- frequency selection, 4-49
- frequency stability, 4-50
- group delay, 4-57
- isolation, 4-52
- LO feedthru, 4-52
- parameters, 4-46
- phase linearity, 4-57
- phase measurements, 4-56
- return loss, 4-53
- RF feedthru, 4-52
- spur analysis, 4-58
- SWR, 4-53
- tuned receiver mode, 4-54
- up conversion, 4-50
- mixers
 - attenuation at ports, 8-3
 - conversion compression, 8-23
 - conversion loss using frequency offset, 8-4
 - conversion loss using tuned receiver mode, 8-14
 - filtering, 8-3
 - fixed IF, 8-14
 - frequency selection, 8-3
 - group delay or phase measurement, 8-20
 - high dynamic range conversion loss, 8-11
 - isolation measurements, 8-28
 - LO to RF isolation, 8-29
 - power meter calibration, 8-34
 - RF feedthrough, 8-31
 - swept RF/IF measurement, 8-4
- modes
 - auto sweep time, 6-27
 - component analyzer, 6-38
 - external source, 6-39
 - frequency offset, 6-44
 - harmonic, 6-47
 - instrument, 6-38
 - tuned receiver, 6-42
- modified colors, recalling/saving, 6-8
- modifying a standard, 13-9
- modifying commands in sequencing, 11-15
- modulation
 - stop frequency, 3-12
 - transfer characteristics, 3-5
 - transfer, source/E/O converter, 2-5
- monitor connector, 1-9
- multimode cable, measuring pulse dispersion, 5-27

N

- noise floor, reducing, 5-17, 6-31
- noise reduction, 3-12
 - averaging, 6-33
 - IF bandwidth, 6-35
 - smoothing, 6-34
- noise trace, reducing, 6-32
- non-allowable keys in sequencing, 11-5
- normalize response of source, 13-35
- number of points, reducing, 6-28

O

- O/E device measurements, 3-4–3-16
 - receiver response, 13-43
 - receiver response and match, 13-45
- O/O device measurement, 5-2
 - reflection, 13-49
 - reflector or Fresnel, 13-53
 - thru cable, 13-53
 - transmission, 13-51
- offset limits menu, 10-6
- ofs/of? display annotation, 6-46
- one port
 - error correction, 13-14
 - reflection calibration, 13-27
- on-wafer measurements, 4-62
- operation, harmonic, 6-47
- optical power reflected, 5-11
- optical reflection measurement, 2-9, 2-12, 3-9, 5-9, 5-17
- optical time domain reflectometer (OTDR), 5-14
- optical transmission measurement, 5-5
 - calibration kits, 13-4
- optimizing calibration standards, 13-20
- option 002, 6-47
- options for printing/plotting, 12-8

OTDR optical time domain reflectometer, 5-14

output

- bus pin locations (GPIO mode), 11-8
- ports, 1-5
- power, lowering, 4-40

P

P1 and P2 on the plotter, 12-15

parallel port

- GPIO mode, 11-7
- input pin locations (GPIO mode), 11-8
- TTL input, 11-8
- TTL output, 11-7

parameters set with markers

- center frequency, 7-15
- CW frequency, 7-18
- display reference, 7-17
- electrical delay, 7-19
- frequency span, 7-16
- start/stop frequency, 7-13

pass/fail testing using limit lines, 10-2

passband

- flatness measurement, 7-37
- flatness/ripple with markers, 7-37
- ripple measurement, 7-37

peak response measurement, 4-24

pen number settings, 12-13

performance verification

- measurement accuracy, 6-10

phase

- change, rate of, 4-13
- display format, iv, 6-14
- distortion measurement, 3-11, 4-18
- drift, reference plane, 6-11
- linearity, mixer testing, 4-57
- linearly changing, 4-17
- measurement, mixer testing, 4-56
- response, 3-13
- response, correcting variations, 13-35
- shift, 4-16
- shift, higher order, 4-12
- tracking, mixer testing, 4-56

picture, saving, 9-10

plot absolute HP-GL command, 11-10

plotter

- connecting, 12-17
- P1 and P2, 12-15
- pen number settings, 12-13
- type, 12-21

plotting

- arrays, 12-12
- components defined, 12-12
- default values, 12-9
- defined boundaries, 12-15
- file extension, 12-4
- measurements, 12-2-12-23
- options, 12-8
- solving problems, 12-23
- speed, 12-16

point limit creation, 10-15

points, data, reducing, 6-28

polar

- display, 7-30
- display format, iv, 6-17
- format, 7-6, 7-40
- format markers, 7-31
- marker, 7-6
- marker menu, 7-6

polar chart markers

- LIN MKR, 7-31
- LOG MKR, 7-31
- Re/Im MKR, 7-31

port

- coupling, 1-23
- extension vs. electrical delay, 6-11
- extensions, 6-11
- power, decoupled, 6-5
- power, increasing, 6-30

power

- coupling, 1-23, 4-43
- coupling between channels, 6-48
- increasing test port, 6-30
- ranges, 1-22
- switch, 1-4

power meter calibration

- continuous correction mode, 13-63
- for mixer measurements, 8-34
- receiver to measure absolute power, 13-65
- sample-and-sweep correction mode, 13-61

power sensor calibration data, 13-57

power sweep, 1-28, 4-35

PRESET key, 1-5

printer

- connecting, 12-17
- type, 12-20

- printing
 - default values, 12-8
 - displayed results, iv
 - measurements, 12-2-12-23
 - options, 12-8
 - sequences, 11-22
 - solving problems, 12-23
- PROBE POWER connector, 1-5
- problems
 - with disk storage, 9-12
 - with printing or plotting, 12-23
- pulse dispersion, measuring, 5-27
- pulse width
 - incident signal, 5-29
 - signal comparison, 5-33
- R**
- R channel connector, 1-6
- R+jX display format, 2-10
- range, dynamic, increasing, 6-30
- rate of phase change, 4-13
- ratio measurement
 - channel 1 and 2, 6-24
 - performing, 6-22
- raw data array, saving, 9-7
- Re/Im MKR, 7-31
- reading sequences using HP-IB, 11-11
- real display format, 6-20
- real or imaginary display format, iv
- rear panel
 - connectors, 1-9-1-10
 - features, 1-9
- recalling modified colors, 6-8
- receiver
 - calibration data, 13-4
 - calibration procedure, 13-65
 - crosstalk, reducing, 4-30, 6-32, 6-37
 - input measurement, 3-9
 - measurements, 3-5
 - mode, tuned, 8-15
 - noise floor, reducing, 6-31
 - optical reflection measurements, 3-10
 - output measurement, 3-10
 - response and match calibration, 13-45
 - response calibration, 13-43
- reducing
 - averaging factor, 6-28
 - number of measurement points, 6-28
 - receiver crosstalk, 4-30, 6-32, 6-37
 - receiver noise floor, 6-31
 - trace noise, 3-2, 6-32
- reducing noise
 - averaging, 6-33
 - IF bandwidth, 6-35
 - smoothing, 6-34
- reference plane, 13-16
 - extending, 6-11
 - measurement, 5-18
 - phase drift, 6-11
- reflected optical power, 5-11
- reflection coefficient, 2-9
 - measurement with markers, 7-38
- reflection measurements, iii, 2-8, 3-8, 5-8
 - admittance, 7-41
 - calibration kits, 13-4
 - coefficient measurement trace, 7-38
 - error-correction, 13-49
 - Fresnel, 5-18
 - impedance, 7-41
 - length of a single-mode cable, 5-16
 - standing wave ratio, 7-39
- reflection response
 - frequency domain, 4-28
 - time domain, 4-27
- reflection sensitivity, 5-19
- reflection, definition, 13-53
- relative measurement, 7-20
- renaming a file, 9-5
- repeatability, connector, 6-9
- resolution, improving, 3-16
- response
 - frequency response reflection, 13-22
 - frequency transmission, 13-25
 - function, 6-35
 - function block, 1-5
 - maximum amplitude, 4-5
 - measurement, 13-35
 - receiver calibration, 13-43
 - source calibration, 13-37
 - source thru calibration, 13-39
- response and match calibration, 13-41, 13-45
- results, saving and printing, iv
- return loss
 - connectors, 1-39
 - mixer testing, 4-53

reverse isolation measurement, 4-40
RF feedthrough
 in mixer measurement, 8-31
 mixer testing, 4-52
RF OUT connector, 1-5
ripple/passband with markers, 7-37
running/stopping sequences, 11-21

S

S11 1-port calibration, 2-11
safety considerations, v, 1-2
sample-and-sweep correction mode, 13-61
save/recall registers, 6-4
saving, 11-22
 a data trace to display memory, 6-23
 a memory trace, 9-9
 data, 9-7
 display to a file, 9-10
 displayed results, iv
 measurement data, 9-7, 9-9
 modified colors, 6-8
 pictures, 9-10
 sequences, 11-22
 to DOS/LIF, 9-7-9-11
 traces, 6-21
scale resolution, increasing, 4-18
searching for values with markers
 bandwidth, 7-26
 target amplitude, 7-25
 tracking amplitude, 7-27
searching with markers, 7-24
selecting
 continuous/discrete markers, 7-10
 display format, 6-20
sensor calibration data, 13-57
sequences, 11-22
 building a loop counter, 11-17
 changing the title, 11-22
 command information, 11-5
 creating and editing, 11-12
 creating links, 11-16
 decision making functions, 11-8
 deleting commands, 11-14
 editing, 11-5
 entering with HP-IB, 11-11
 gosub sequence command, 11-6
 help screen, 11-13

 HP-GL commands, 11-10
 inserting commands, 11-14
 modifying commands, 11-15
 non-allowable key, 11-5
 procedures, 8-15-8-19
 running/stopping, 11-21
 size of, 11-6
 titles, 11-6
 TTL input for decision making, 11-8
 using HP-IB, 11-11
 with loop counter, 11-6
setting
 default colors, 6-8
 electrical delay with markers, 7-19
 gate parameters, 4-25
 measurement range, 7-12
sex of type-N calibration standard, 13-16
shortened sweep time, 6-25
signal comparison, pulse width, 5-33
signal flow in a mixer, 8-28
signal separation, 2-9
single point limits, 10-15
single-channel operation, harmonic mode, 4-42
single-mode cable, measuring the length, 5-16
size of sequence instructions, 11-6
sloping limit lines, 10-13
Smith chart, 7-42
 display, 7-30
 display format, iv, 2-10, 6-16
 markers, 7-6, 7-32
 menu, 7-7
smoothing, 6-34
 aperature, 4-19
softkeys, 1-5
solving
 disk storage problems, 9-12
 printing or plotting problems, 12-23
source
 addressing/configuring, 8-15
 attenuator switch protection, 1-24
 calibration data, 13-4
 measurement, 2-2
 modulation transfer, 2-5
 response and match calibration, 13-41
 response calibration, 13-37
 thru response calibration, 13-39
span
 decreasing frequency range, 6-27

- setting for gating, 4-25
- special markers, 7-6
- speed increased, 6-25
- splice measurement, 5-21
- split display, 6-5, 6-23
- spur analysis, mixer testing, 4-58
- spur prediction program, 4-60
- stability, mixer testing, 4-50
- standards
 - modifying, 13-9
- standards, calibration, 13-20
- standing wave ratio (SWR)
 - display format, iv, 6-19
 - measuring with markers, 7-39
 - mixer testing, 4-53
- start values possible, 1-7
- start/stop frequency set with markers, 7-13
- static-safe
 - accessories, 1-32
 - workstation, 1-32
- statistical measurement, 7-28
- statistics calculation, 7-29
- step attenuator, switch protection, 1-24
- stimulus
 - function block, 1-5
 - start value, 1-7
 - stop value, 1-7
 - value, active marker, 7-9
- stop values possible, 1-7
- stopping/running sequences, 11-21
- storing instrument states, 9-5
- subtract memory trace from the measurement
 - data trace, 6-24
- swabs
 - cotton, 1-35
 - foam, 1-35
- sweep
 - how to set auto sweep time, 6-27
 - how to set chop sweep, 6-29
 - speed, changing, 2-2
 - speed, increasing, 6-25, 13-65
 - time, 2-2
 - type, setting, 6-28
- sweep time
 - auto, 1-24
 - fiber-optic cables, 5-15
 - manual, 1-24
- sweep types, 1-27
 - alternate, 1-29
 - chop, 1-29
 - CW time, 1-29
 - linear, 1-27
 - list frequency, 1-27
 - logarithmic, 1-27
 - power, 1-28
- swept measurement
 - power, 4-35
 - power conversion compression, 8-27
 - RF/AF mixer, 8-4
- switch protection, 1-24
- SWR
 - display format, 6-19
 - measurement with markers, 7-39
 - mixer testing, 4-53
 - See standing wave ratio*
- system
 - bandwidth, widening, 6-27
 - characterization, 13-21
- systematic errors, 13-18

T

- target
 - amplitude search, 7-25
 - menu, 7-8
- temperature drift, 6-10
- test port
 - coupling, 1-23
 - power, increasing, 6-30
- test sequences, 11-15, 11-22
 - building a loop counter, 11-17
 - command information, 11-5
 - creating and editing, 11-12
 - decision making functions, 11-8
 - deleting commands, 11-14
 - editing, 11-5
 - gosub sequence command, 11-6
 - GPIO, 11-7
 - help screen, 11-13
 - HP-GL commands, 11-10
 - inserting commands, 11-14
 - running/stopping, 11-21
 - size of, 11-6
 - titles, 11-6
 - using HP-IB, 11-11
 - with loop counter, 11-6

test set hold mode, 1-24
thru cable, defining, 13-53
time domain
 gating procedure, 4-22
 measurements, iv, 5-14–5-34
 measuring, 4-22
 reflection response, 4-27
 transmission response measurement, 4-24
 velocity factor, 4-28
tint, changing display, 6-7
titles
 changing in sequences, 11-22
 in sequences, 11-6
trace
 deviation, 4-18
 display, adjusting, 5-32
 displaying and saving, 6-21
 math, 6-5, 6-24
 noise, reducing, 2-2, 6-32
 viewing, 6-24
tracking an amplitude, 7-27
transmission line, lossless, 4-15
transmission measurements, iii, 2-4, 3-4, 5-4
 3 dB bandwidth, 7-35
 correcting, 13-35
 error-correction, 13-51
 passband flatness, 7-37
 passband ripple, 7-37
transmission response in time domain, 4-24
TRL standard modification, 13-11
TRL* calibration, 4-62
 user-defined kit, 13-8
TRL* error correction, 13-15
TRM* calibration, 13-33
tsh annotation, 4-40
TTL I/O, 11-7
TTL input decision making, 11-9
 in sequencing, 11-8
tuned receiver mode, 6-42, 8-14
 applications, 6-42
 conversion loss, 8-15
 description, 6-43
 initializing, 8-15
 mixer testing, 4-54
 test setup, 6-42
turning off
 all markers, 7-10
 output, 1-32

two-port calibration, 13-30
type of sweep, setting, 6-28
type-N calibration standard sex, 13-16
typical standard types, 13-9

U
uncoupled marker, 7-11
uncoupling
 channels, 4-41
 display markers, 7-11
up conversion, mixer testing, 4-50
user-defined electrical kits, 13-7
using limit lines, 10-2–10-16

V
variations
 correcting, 13-35
 in frequency aperture, 4-14
velocity factor
 changing, 4-9
 time domain, 4-28, 5-17
viewing
 both measurement channels, 6-23
 data and memory trace, 6-24

W
widen system bandwidth, 6-27
